

Operating instructions

Tightness control TC 1, TC 2, TC 3



Contents

Tightness control TC 1, TC 2, TC 3	1
Contents	1
Safety	1
Checking the usage	2
Installation	3
Mounting TC 1V to valVario controls	3
VAS 6–9, VCS 6–9	3
Mounting TC 1C to combination control CG ...	4
Mounting TC 2	4
Mounting TC 3	4
Wiring	5
Preparing the wiring	5
Connection diagram for TC 1, TC 2	5
Connection diagram for TC 3	6
Finishing the wiring	6
Tightness test	6
Setting the test instant	6
Setting measurement time t_M	7
Commissioning	8
Indicators and operating controls	8
Power failure	8
Assistance in the event of malfunction	8
Replacing the fuse	9
Maintenance	9
Technical data	10
Safety information in accordance with EN 61508-2	10
Logistics	11
Certification	11
Contact	12

Safety

Please read and keep in a safe place



Please read through these instructions carefully before installing or operating. Following the installation, pass the instructions on to the operator. This unit must be installed and commissioned in accordance with the regulations and standards in force. These instructions can also be found at www.docuthek.com.

Explanation of symbols

■, **1**, **2**, **3**... = Action

> = Instruction

Liability

We will not be held liable for damage resulting from non-observance of the instructions and non-compliant use.

Safety instructions

Information that is relevant for safety is indicated in the instructions as follows:

⚠ DANGER

Indicates potentially fatal situations.

⚠ WARNING

Indicates possible danger to life and limb.

! CAUTION

Indicates possible material damage.

All interventions may only be carried out by qualified gas technicians. Electrical interventions may only be carried out by qualified electricians.

Conversion, spare parts

All technical changes are prohibited. Only use OEM spare parts.

Changes to edition 08.17

The following chapters have been changed:

- Installation
- Wiring
- Certification

Checking the usage

TC

Tightness control for checking two safety valves before and after burner run, with adjustable measurement time for adjustment to different test volumes, leakage rates and inlet pressures. The TC is used in industrial thermoprocessing equipment, on boilers and on forced draught burners.

TC 1, TC 2

For gas solenoid valves, quick opening or slow opening with start gas rate.

TC 3

With fitted auxiliary valves for quick or slow opening gas solenoid valves as well as for motorized valves.

This function is only guaranteed when used within the specified limits – see page 10 (Technical data). Any other use is considered as non-compliant.

Type code

Code	Description
TC	Tightness control
1V	For attachment to valVario
1C	For attachment to CG
2	For quick opening individual valves
3	For quick or slow opening valves
R	With Rp internal thread
N	With NPT internal thread
05	p_u max. 500 mbar Mains voltage:
W	230 V AC, 50/60 Hz
Q	120 V AC, 50/60 Hz
K	24 V DC
	/
	Control voltage:
W	230 V AC, 50/60 Hz
Q	120 V AC, 50/60 Hz
K	24 V DC

Part designations

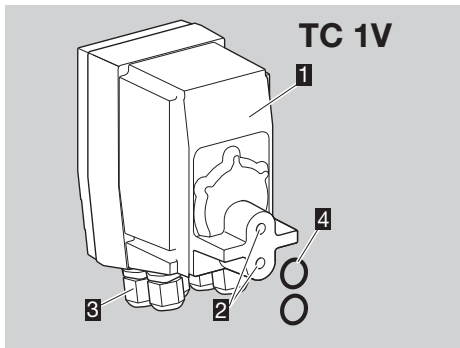

- 1 TC 1V
- 2 Connectors
- 3 5 x M16 cable glands
- 4 2 x O-rings

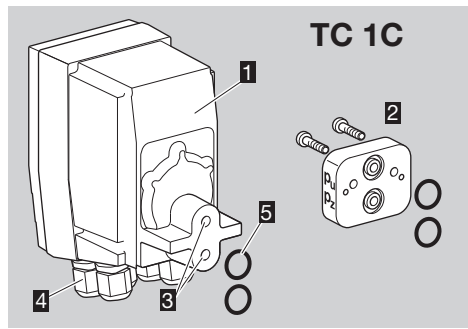

- 1 TC 1C for combination controls CG
- 2 1 x adapter
2 x O-rings
2 x retaining screws
- 3 Connectors
- 4 5 x M16 cable glands
- 5 2 x O-rings

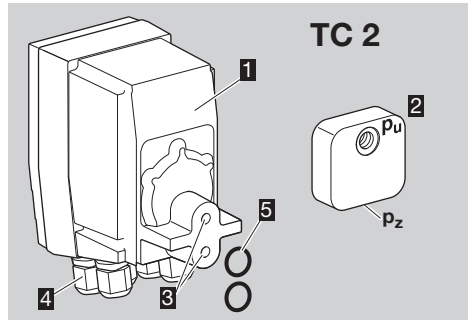

- 1 TC 2 for solenoid valves
- 2 1 x adapter
2 x O-rings
2 x retaining screws
- 3 Connectors
- 4 5 x M16 cable glands
- 5 2 x O-rings

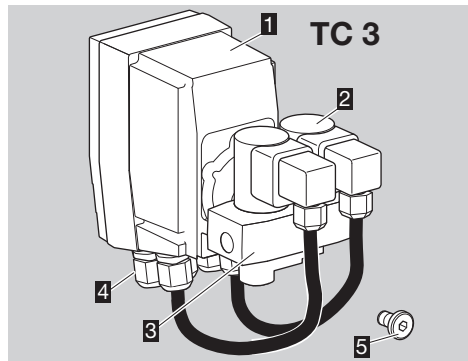

- 1 TC 3
- 2 Auxiliary valves
- 3 Valve block
- 4 5 x M16 cable glands
- 5 1 x screw plug

Type label

- ▷ Gas type, measurement time, installation position, mains voltage, mains frequency, power consumption, ambient temperature, enclosure, max. switch-on current and max. inlet pressure – see type label.

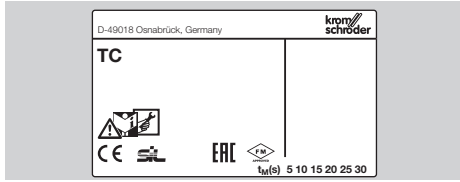

Installation

! CAUTION

Please observe the following to ensure that the unit is not damaged during installation and operation:

- Dropping the device can cause permanent damage. In this event, replace the entire device and associated modules before use.
 - Avoid formation of condensation in the device.
 - Do not store or install the unit in the open air.
 - Check max. inlet pressure.
 - Use a suitable spanner. Do not use the device as a lever. Risk of external leakage.
- ▷ Installation in the vertical or horizontal position, housing cover/indicators must not point upwards or downwards. The electrical connection should preferably be pointing downwards or towards the outlet.

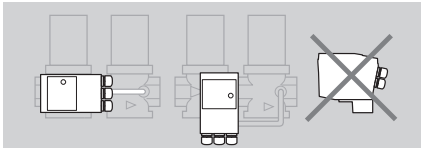

- ▷ The device must not be in contact with masonry. Minimum clearance 20 mm (0.78").
- ▷ Use the O-rings supplied.
- ▷ In the case of very large test volumes V_P , an installed relief line should be of nominal size 40 to allow for the discharge of the test volume V_P .

1 Disconnect the system from the electrical power supply.

2 Shut off the gas supply.

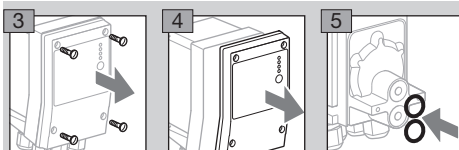

- ▷ The O-rings must be inserted in the connectors of the TC.

Mounting TC 1V to vaVario controls

- ▷ The solenoid actuator cannot be rotated on solenoid valves with proof of closure switch VCx..S or VCx..G.
- ▷ Connect the TC to the inlet pressure connection p_u and the interspace pressure connection p_z of the inlet valve. Ensure that connections p_u and p_z on the TC and the gas solenoid valve are not reversed.
- ▷ TC and bypass/pilot gas valve cannot be fitted together on the same side of the double block valve.
- ▷ When using a valve/pressure regulator combination VCG/VCV/VCH, the pressure regulator must be activated with air during the entire test period t_P .
- ▷ The TC is secured using two captive combination Torx screws T20 (M4) inside the housing. Do not undo any other screws!

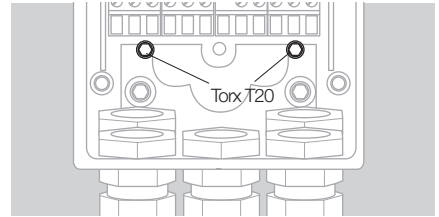

VAS 1–3, VCx 1–3

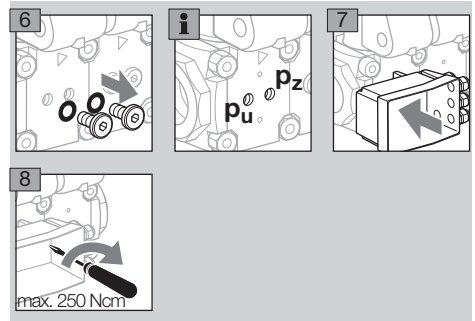

VAS 6–9, VCS 6–9

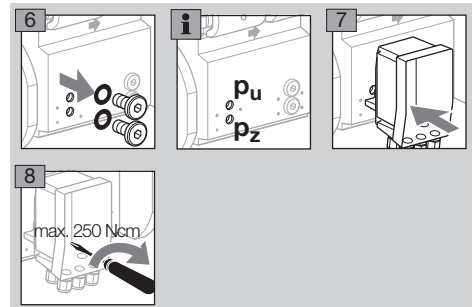

Mounting TC 1C to combination control CG

- ▷ Use the adapter plate supplied to mount the TC 1C to combination control CG.
- ▷ Connect the TC to the inlet pressure connection p_u and the interspace pressure connection p_z of the inlet valve. Ensure that connections p_u and p_z on the CG are not reversed.

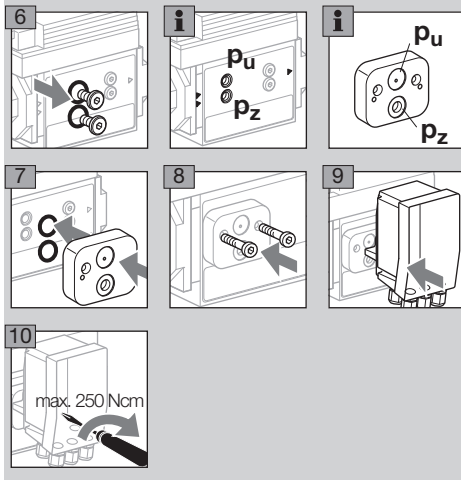

Mounting TC 2

- ▷ Connect the TC to the inlet pressure connection p_u and the interspace pressure connection p_z of the inlet valve.
- ▷ Use the adapter plate supplied for installation.

TC 2..R: Rp 1/4
TC 2..N: 1/4 NPT

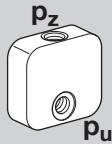

- ▷ We recommend using Ermeto screw couplings to attach the adapter plate to the gas solenoid valve. It may be necessary to compensate the distance to the valve housing.

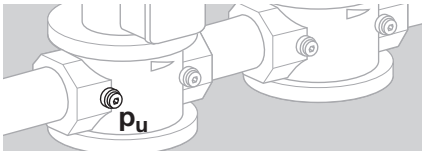

- ▷ Only use approved sealing material to seal the pipe connections.

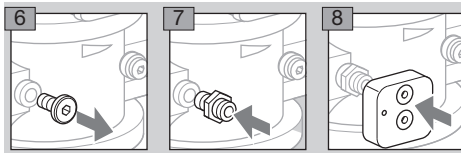

- ▷ Connect the interspace pressure connection p_z on the adapter plate to the space between the valves using a 12 x 1.5 or 8 x 1 pipe.

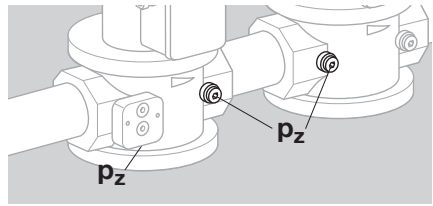

- ▷ Ensure that connections p_u and p_z on the TC and adapter plate are not reversed.

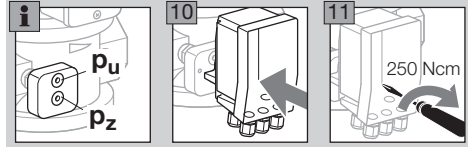

Mounting TC 3

- ▷ Connect the TC to the inlet pressure connection p_u , the interspace pressure connection p_z and the outlet pressure connection p_d of the inlet valve. Ensure that connections p_u , p_z and p_d on the TC are not reversed.
- ▷ TC 3..R: Rp 1/4, TC 3..N: 1/4 NPT

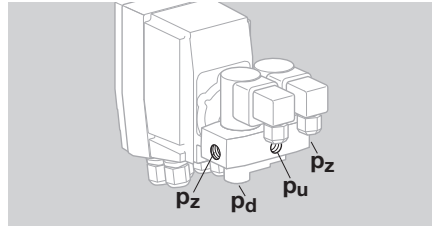

- ▷ Use a 12 x 1.5 or 8 x 1 pipe for the pipe connections.

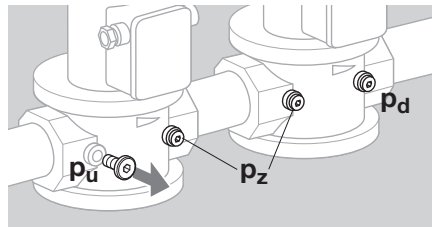

- ▷ Mount TC 3.
- ▷ Only use approved sealing material to seal the pipe connections.
- ▷ Seal the unused connection p_z on the TC using the sealing plug supplied.

Wiring

⚠ WARNING

Electric shocks can be fatal!

- Before working on possible live components, ensure the unit is disconnected from the power supply.
- Incorrect wiring may result in unsafe states and the destruction of the tightness control, the automatic burner control unit or the valves.
- Do not reverse L1 (+) and N (-).
- Cable cross-sections must be designed for the current rating of the selected external fuse.
- The valve outputs on the automatic burner control unit connected to the TC must be safeguarded by an external slow-acting fuse of max. 5 A (e.g. in the automatic burner control unit).

- ▷ Wiring to EN 60204-1.
- ▷ Use connection terminals with a cable cross-section of max. 2.5 mm².
- ▷ Conductors which have not been connected (spare conductors) must be insulated at their ends.
- ▷ Do not set the remote reset so that it operates (automatically) in cycles.
- ▷ The data on the type label must comply with the mains voltage.
- ▷ Length of the connection cable, see page 10 (Technical data).

! CAUTION

Please observe the following to ensure that the unit is not damaged during operation:

- Avoid voltage and current peaks! It is recommended to equip connected valves with a protective circuit in accordance with the manufacturer's instructions.

- 1** Disconnect the system from the electrical power supply.
- 2** Shut off the gas supply.
 - ▷ Before opening the unit, the fitter should ground himself.
- 3** Open the housing cover of the TC.

Preparing the wiring

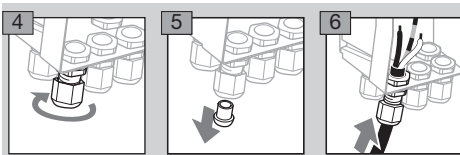

- 7** Secure used cable glands. Tightening torque: max. 3.5 Nm.
 - ▷ Unused cable glands are to remain closed with a plug. Otherwise, dirt or moisture can penetrate the housing.
- 8** Wire as shown on the connection diagram.

- ▷ For PE wire connection, 5 PE terminals are available for forwarding. They are designed as distributor terminals, e.g. to connect the PE wires of the valves to the system PE (connection to the system PE must be carried out/wired by the user).

Connection diagram for TC 1, TC 2

Mains voltage and control voltage:
24 V DC/120 V AC/230 V AC

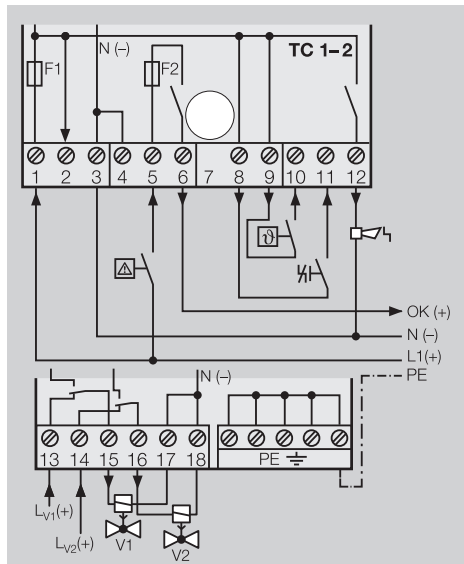

Mains voltage: 120 V AC/230 V AC,
control voltage: 24 V DC

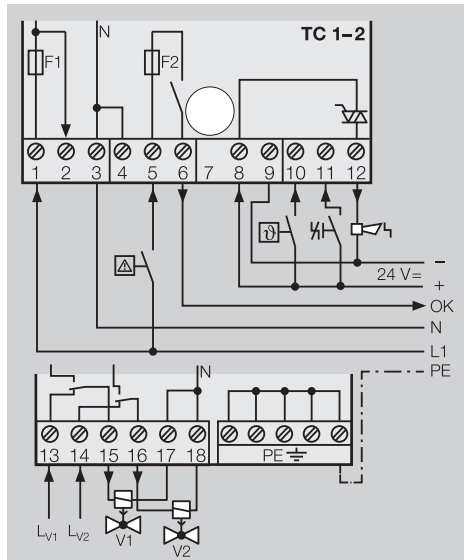

Connection diagram for TC 3

- ▷ The tightness test is carried out with the auxiliary valves installed on TC 3 (pre-wired). The terminals for the valve inputs remain vacant.

Mains voltage and control voltage:

24 V DC/120 V AC/230 V AC

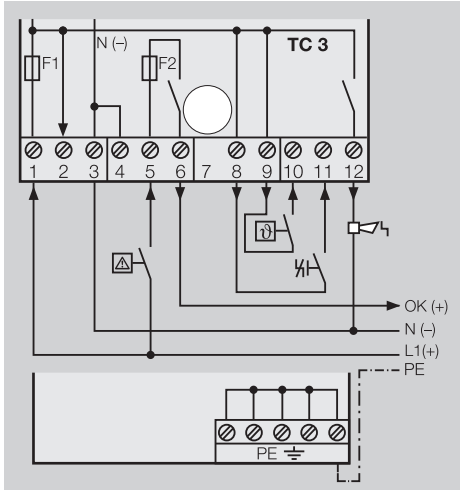

Mains voltage: 120 V AC/230 V AC,
control voltage: 24 V DC

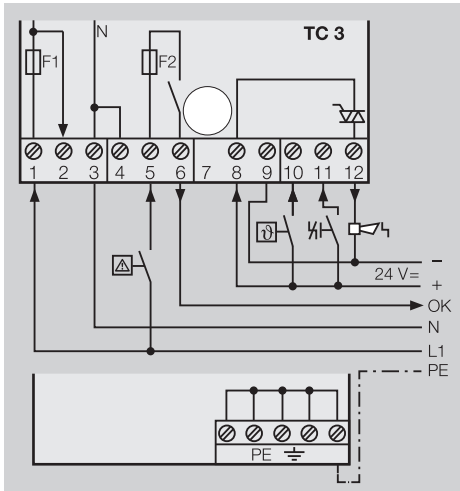

Finishing the wiring

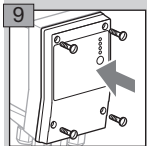

Tightness test

- ▷ All new connections between the valve and the TC must be checked for tightness.

- 1 Pressurize the system. Do not exceed the maximum inlet pressure.
- 2 Soap off pipe connections.

Setting the test instant

- ▷ The test instant (MODE) can be set using two DIP switches.

- 1 Disconnect the unit from the electrical power supply.
- ▷ Before opening the unit, the fitter should ground himself.
- 2 Unscrew the housing cover.
- 3 Set the test instant to Mode 1, 2 or 3.

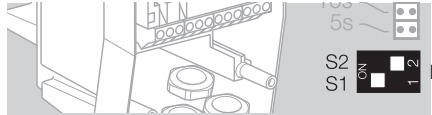

- ▷ Mode 1: test before burner start-up with incoming thermostat/start-up signal ϑ (factory setting).

S2 ON 1 2 Mode 1

- ▷ Mode 2: test after burner run when the thermostat/start-up signal ϑ drops and after switching on the mains voltage.

- ▷ The tightness test also starts after a reset.

S2 ON 1 2 Mode 2

- ▷ Mode 3: test with incoming thermostat/start-up signal ϑ before burner start-up and when the thermostat/start-up signal ϑ drops after burner run.

S2 ON 1 2 Mode 3

- ▷ Invalid switch setting: no function. The \varnothing LED is permanently red, see page 8 (Assistance in the event of malfunction).

S2 ON 1 2

- ▷ Continue on page 7 (Setting measurement time tM).

Setting measurement time t_M

- ▷ The measurement time t_M can be set with a jumper in increments of 5 s to max. 30 s.
- ▷ t_M is set to 30 s at the factory.

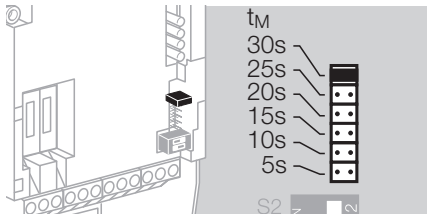

- ▷ No jumper: no function. The Φ LED is permanently red, see page 8 (Assistance in the event of malfunction).
- ▷ The longer the measurement time t_M , the greater the sensitivity of the tightness control. The longer the measurement time, the smaller the leakage rate at which a safety shut-down/fault lock-out is triggered.
- ▷ For all CG versions, the measurement time t_M must be set to 5 s on TC 1C.
- ▷ If no leakage rate is specified, we recommend the max. measurement time is set.
- ▷ Within the scope of the European Union, the maximum leakage rate Q_L is 0.1% of the maximum flow rate Q_{max} . [m^3/h (n)].
- ▷ If a leakage rate is specified, find the measurement time t_M from the following:
 - Q_{max} = max. flow rate [m^3/h]
 - $Q_L = Q_{max}$ [m^3/h] \times 0.1% = leakage rate [l/h]
 - p_u = inlet pressure [mbar]
 - V_P = test volume [l], see page 7 (Values for valve and pipe volume)
- ▷ The tightness control TC requires a minimum start rate in order to carry out tightness tests on slow opening valves:
 - up to 5 l (1.3 gal) test volume $V_P = 5\%$ of maximum flow rate Q_{max} .
 - up to 12 l (3.12 gal) test volume $V_P = 10\%$ of maximum flow rate Q_{max} .

1 Determine measurement time t_M .

- ▷ Measurement times t_M for V1 and V2:

$$t_M [s] = \frac{2.5 \times p_u [\text{mbar}] \times V_P [l]}{Q_L [l/h]}$$

- ▷ The entire test period is made up of the measurement times t_M of both valves and the fixed opening time t_L of both valves together:

$$t_P [s] = 2 \times t_L + 2 \times t_M$$

Values for valve and pipe volume

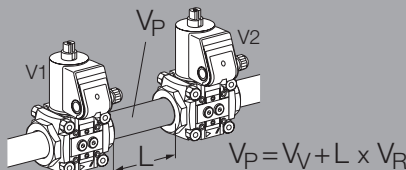

Valves	Valve volume V_V [l]	Nominal size DN	Pipe volume V_R [l/m]
VG 10	0.01	10	0.1
VG 15	0.07	15	0.2
VG 20	0.12	20	0.3
VG 25	0.2	25	0.5
VG 40/VK 40	0.7	40	1.3
VG 50/VK 50	1.2	50	2
VG 65/VK 65	2	65	3.3
VG 80/VK 80	4	80	5
VG 100/VK 100	8.3	100	7.9
VK 125	13.6	125	12.3
VK 150	20	150	17.7
VK 200	42	200	31.4
VK 250	66	250	49
VAS 1	0.08		
VAS 2	0.32		
VAS 3	0.68		
VAS 6	1.37		
VAS 7	2.04		
VAS 8	3.34		
VAS 9	5.41		
VCS 1	0.05		
VCS 2	0.18		
VCS 3	0.39		
VCS 6	1.11		
VCS 7	1.40		
VCS 8	2.82		
VCS 9	4.34		

Calculation example:

$$Q_{max} = 100 \text{ m}^3/\text{h}$$

$$p_u = 100 \text{ mbar}$$

$$V_P = V_V + L \times V_R = 7 \text{ l}$$

$$Q_L = 100 \text{ m}^3/\text{h} \times 0.1\% = 100 \text{ l/h}$$

$$\frac{2.5 \times 100 \times 7}{100} = 17.5 \text{ s}$$

Set the next highest value (in this example 20 s) with the jumper.

- 2 Disconnect the unit from the electrical power supply.
- 3 Unscrew the housing cover.
- 4 Set the jumper to the position for the required measurement time.
- 5 Position the housing cover and screw tight.
- 6 Mark the set measurement time t_M on the type label with a waterproof pen.



ERC



$t_M(s)$ 5 10 15 20 25 30

- ▷ The entire test period for this example is as follows: $2 \times 3 \text{ s} + 2 \times 20 \text{ s} = 46 \text{ s}$.

7 Switch on the power supply.

- ▷ The \odot LED flashes yellow (0.2 s on/off). After 10 s, the TC accepts the new setting and \odot is yellow or green, see table on page 8 (Commissioning).

Commissioning

Indicators and operating controls

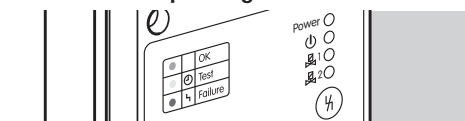

Power \odot = power supply

\odot = operating signal

\odot 1 = valve 1

\odot 2 = valve 2

\odot H = reset button

The LEDs can display messages using three colours (green, yellow, red) and permanent \odot or flashing light \odot :

LED	Messages/Operating status
Power \odot green	Power supply OK
\odot yellow	TC is ready for operation; no safety interlock* input signal
\odot green	TC is ready for operation; active safety interlock* input signal
\odot 1 green	V1 is tight
\odot 1 yellow	V1 is untested
\odot 1 yellow	Tightness test is running on V1
\odot 1 red	V1 is leaking
\odot 2 green	V2 is tight
\odot 2 yellow	V2 is untested
\odot 2 yellow	Tightness test is running on V2
\odot 2 red	V2 is leaking
All yellow	Initialization

* Linking of all the relevant safety control and switching equipment for the use of the application. The burner start enable signal is issued via the safety interlock output (terminal 6).

- ▷ For further messages, see page 8 (Assistance in the event of malfunction).

1 Switch on the mains voltage.

- ▷ All LEDs are yellow for 1 s. The TC is in the initialization phase.

- ▷ The test starts according to the test instant (Mode) which has been set.

Mode 1 or Mode 3, test before burner start-up: voltage is applied to terminal 10 (thermostat/start-up signal ϑ).

Or

Mode 2, test after burner run: the TC shows the last operating status. In the case of untested valves, the LEDs \odot 1 and \odot 2 are yellow. There is mains voltage at terminal 1 and renewed test after switching off the voltage to terminal 10 (thermostat/start-up signal ϑ).

- ▷ During the test, the \odot 1 or \odot 2 LED flashes yellow.

The \odot 1 and \odot 2 LEDs are green:

- ▷ Both valves are tight.

Mode 1 or Mode 3: the enable signal is issued via terminal 6 when voltage is applied to terminal 5. Or

Mode 2: the enable signal is issued via terminal 6 when voltage is applied to terminals 10 and 5.

The \odot 1 or \odot 2 LED is red:

- ▷ A valve is leaking.
- ▷ Voltage at terminal 12. A fault signal is output.

Power failure

- ▷ If the power fails briefly during the test or during operation, the tightness test will restart in accordance with the test procedure described above.
- ▷ If there is a fault message, the fault is displayed again after a power failure.

Assistance in the event of malfunction

! CAUTION

Electric shocks can be fatal!

- Before working on possible live components, ensure the unit is disconnected from the power supply.
- Fault-clearance must only be undertaken by authorized trained personnel!
- (Remote) resets may only be conducted by authorized trained personnel.

- Faults may be cleared only using the measures described below.
- Press the reset button to test whether the TC restarts.
- ▷ If the tightness control will not start even though all faults have been remedied, remove the entire TC (in the case of TC 3, including auxiliary valves and corresponding valve block) and send it to the manufacturer for inspection.

? Fault

! Cause

• Remedy

- ? Power \odot red and permanently lit?

! There is over-/undervoltage. The TC performs a safety shut-down.

- Check the mains voltage. As soon as there is no longer over-/undervoltage, the TC returns to normal operating mode and the Power \odot LED is green. It is not necessary to reset the device.

? ⏻ ○ yellow and permanently lit?

! Safety interlock input signal is interrupted, no voltage at terminal 5. The tightness test is still being carried out. No enable signal is issued to the automatic burner control unit.

- Check safety interlocks.
- !** Fuse F2 defective.
- Replace fuse F2, see page 9 (Replacing the fuse).

? ⏻ ⚡ yellow and flashing?

! Permanent remote reset. The remote reset signal has been active for more than 10 s.

- The warning signal is cancelled once the remote reset signal to terminal 11 has been removed.

? ⏻ ○ red and permanently lit?

! Incorrect jumper/DIP switch setting.

- Correct jumper and DIP switch setting, see pages 7 (Setting measurement time t_M) and 6 (Setting the test instant). Then press the reset button.

! Internal error.

- Remove the unit and return it to the manufacturer for inspection.

? ⏻ ⚡ red and flashing?

! Too frequent burner start commands. The TC performs a fault lock-out. The start commands are limited to 5 x in 15 minutes.

- ▷ As long as this limit is not exceeded, another start-up attempt is possible after three further minutes. If a tightness test is completed, the counter which limits the number of start commands is reset.

- Then press the reset button.

! Too many remote resets. More than 5 resets have been conducted within the last 15 minutes, either automatically or manually.

! Consecutive fault caused by a previous fault whose actual cause has not been remedied.

- Pay attention to previous fault messages.
- Remedy cause. Then press the reset button.

? ⚡1 ○ or ⚡2 ○ red and permanently lit?

! The valve is leaking. The TC performs a fault lock-out.

- Replace the valve.

! Wiring of the TC to the valves is faulty.

- Start the program and observe the interspace pressure p_z . The pressure must change during the TEST phase. Check the wiring.

! Inlet pressure $p_u < 10$ mbar.

- Provide the min. inlet pressure of 10 mbar.

! Interspace pressure p_z cannot be reduced.

• The volume downstream of the valve on the burner side must be 5 times higher than the volume between the valves and atmospheric pressure must prevail.

! The measurement time t_M is too long.

- Readjust t_M , see page 7 (Setting measurement time t_M).

? ⚡1 ○ and ⚡2 ○ red and permanently lit?

! During the tightness test, the TC has determined that inlet valve 1 and outlet valve 2 have been reversed (fault lock-out).

- Check the wiring. Then press the reset button.

? No LED lit even though mains voltage applied?

! Fuse F1 defective.

- Replace fuse F1, see page 9 (Replacing the fuse).

Replacing the fuse

▷ The fuses F1 and F2 can be removed for inspection.

▷ Insert a screwdriver into the opening in the contact guard to prise out the fuse.

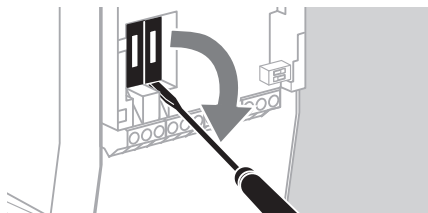

1 Disconnect the TC from the electrical power supply.

▷ Before opening the unit, the fitter should ground himself.

2 Unscrew the housing cover.

3 Remove fuse F1 or F2.

4 Check function of fuse.

5 Replace the defective fuse.

▷ When replacing the fuse, use only the approved fuse type, see page 10 (Technical data).

▷ Restart the TC, see page 8 (Commissioning).

Maintenance

Tightness controls TC require little servicing. We recommend carrying out a function check once a year or twice a year in the case of biogas.

Technical data

Electrical data

Mains voltage and control voltage:

120 V AC, -15/+10%, 50/60 Hz,

230 V AC, -15/+10%, 50/60 Hz,

24 V DC, $\pm 20\%$.

Power consumption (all LEDs green):

5.5 W at 120 V AC and 230 V AC,

2 W at 24 V DC,

TC 3: plus 8 VA for an auxiliary valve.

Fine-wire fuse:

5 A, slow-acting, H, 250 V, pursuant to

IEC 60127-2/5,

F1: protection of valve outputs (terminals 15 and 16), fault signal (terminal 12) and supply of the control inputs (terminals 2, 7 and 8).

F2: protection of the safety interlock/controller enable signal (terminal 6).

The input current at terminal 1 must not exceed 5 A.

Max. load current for safety interlock/controller enable and valve outputs:

at 230/120 V AC mains voltage, max. 3 A resistive load,

at 24 V DC mains voltage, max. 5 A resistive load.

External fault signal (terminal 12):

fault output at 120 V AC/230 V AC/24 V DC mains

and control voltage: max. 5 A,

fault output at 120 V AC/230 V AC mains voltage,

24 V DC control voltage: max. 100 mA.

TC switching cycles:

250,000 pursuant to EN 13611.

Reset: using a button on the device or by remote reset.

Environment

Gas type: natural gas, town gas, LPG (gaseous), biogas (max. 0.1 %-by-vol. H₂S) and air.

The gas must be clean and dry in all temperature conditions and must not contain condensate.

Inlet pressure p_{i1} : 10 to 500 mbar (3.9 to 195 "WC).

Measurement time t_M : 5 to 30 s, adjustable.

Set at the factory to 30 s.

Medium and ambient temperatures:

-20 to +60°C (-4 to +140°F).

No condensation permitted.

Long-term use in the upper ambient temperature range accelerates the ageing of the elastomer materials and reduces the service life.

Storage temperature: -20 to +40°C (-4 to +104°F).

Max. installation altitude: 2000 m AMSL.

Mechanical data

Length of connection cable:

at 230 V AC/120 V AC: any,

at 24 V DC (supply connected to PE):

max. 10 m permitted,

at 24 V DC (supply not connected to PE): any.

5 cable glands: M16 x 1.5.

Electrical connection:

Cable cross-section: min. 0.75 mm² (AWG 19),

max. 2.5 mm² (AWG 14).

Valve opening time: 3 s.

Housing made of impact-resistant plastic.

Connectors: aluminium.

Enclosure: IP 65.

Weight:

TC 1V: 215 g

TC 1C: 260 g (including adapter)

TC 2: 260 g (including adapter)

TC 3: 420 g

Designed lifetime

This information on the designed lifetime is based on using the product in accordance with these operating instructions. Once the designed lifetime has been reached, safety-relevant products must be replaced. Designed lifetime (based on date of manufacture) in accordance with EN 13611 for TC 1 – 3: 250,000 switching cycles.

You can find further explanations in the applicable rules and regulations and on the afecor website (www.afecor.org).

This procedure applies to heating systems. For thermoprocessing equipment, observe local regulations.

Safety information in accordance with EN 61508-2

See Technical Information TC (D, GB, F) – www.docuthek.com

Logistics

Transport

Protect the unit from external forces (blows, shocks, vibration). On receipt of the product, check that the delivery is complete, see page 2 (Part designations). Report any transport damage immediately.

Storage

Store the product in a dry and clean place.

Storage temperature: see page 10 (Technical data).

Storage time: 6 months in the original packaging before using for the first time. If stored for longer than this, the overall service life will be reduced by the corresponding amount of extra storage time.

Packaging

The packaging material is to be disposed of in accordance with local regulations.

Disposal

Components are to be disposed of separately in accordance with local regulations.

Certification

Declaration of conformity



We, the manufacturer, hereby declare that the product TC 1 – 3 with product ID No. CE-0085CS0076 complies with the requirements of the listed Directives and Standards.

Directives:

- 2014/35/EU – LVD
- 2014/30/EU – EMC

Regulation:

- (EU) 2016/426 – GAR

Standards:

- EN 1643:2014
- EN 60730-2-5:2015
- EN 61000-6-2:2005
- EN 61508:2010, Parts 1–7
- SIL 3 according to EN 61508

The relevant product corresponds to the tested type sample.

The production is subject to the surveillance procedure pursuant to Regulation (EU) 2016/426 Annex III paragraph 3.

Elster GmbH

Scan of the Declaration of conformity (D, GB) – see www.docuthek.com

Directive on the restriction of the use of hazardous substances (RoHS) in China

Scan of the Disclosure Table China RoHS2 – see certificates at www.docuthek.com

AGA approved

In preparation



Australian Gas Association

Eurasian Customs Union



The product TC 1–3 meets the technical specifications of the Eurasian Customs Union.

SIL, PL



For systems up to SIL 3 pursuant to EN 61508. Pursuant to EN ISO 13849-1, Table 4, TC 1, TC 2 and TC 3 can be used up to PL e.

Safety-specific characteristic values

Mains and control voltage: 120 V AC/230 V AC	
Diagnostic coverage DC	91.4%
Mean probability of dangerous failure PFH _D	17.3 x 10 ⁻⁹ 1/h
Mains voltage: 120 V AC/230 V AC, control voltage: 24 V DC	
Diagnostic coverage DC	91.3%
Mean probability of dangerous failure PFH _D	17.2 x 10 ⁻⁹ 1/h
Mains and control voltage: 24 V DC	
Diagnostic coverage DC	91.5%
Mean probability of dangerous failure PFH _D	17.5 x 10 ⁻⁹ 1/h
General	
Mean probability of dangerous failure PFH _D	Auxiliary valves with valve block on TC 3: 0.2 x 10 ⁻⁹ 1/h
Type of subsystem	Type B to EN 61508-2
Operating mode	High demand mode pursuant to EN 61508-4 Continuous operation (to EN 1643)
Mean time to dangerous failure MTTF _d	1/PFH _D
Safe failure fraction SFF	97.5%

Contact

If you have any technical questions, please contact your local branch office/agent. The addresses are available on the Internet or from Elster GmbH.

We reserve the right to make technical modifications in the interests of progress.

Honeywell

krom/schroder

Elster GmbH
Strotheweg 1, D-49504 Lotte (Büren)

Tel. +49 541 1214-0

Fax +49 541 1214-370

hts.lotte@honeywell.com, www.kromschroeder.com