



R-125, RS-125

**Medium pressure regulators for gas
DN25 ... DN50**

R-125, RS-125

Medium pressure regulators for gas

Contents

Description	2
Features	2
Technical specifications	3
Selection and installation notes.....	5
Ordering information	10
Standards and approvals	11

Description

The R type is a medium pressure regulator for gas according with EN 334. It is available also with a safety shut-off valve which blocks gas flow in the event of a spike or drop in the outlet pressure, in accordance with EN 14382. This device is suitable for supplying gas at stable pressure to all the devices downstream and to protect them against excess of pressure.

Features

R series pressure regulators are direct-acting spring-loaded regulator type, controlled by a diaphragm and spring. The balanced valve design ensures a constant pressure setting when upstream pressure varies.

RS version is an R regulator with an integrated safety shut off device against abnormal outlet pressure. Shut off valve system is independent from regulating device, to assure an high level of safety.

Devices are designed and manufactured in accordance with norm EN 334 (Gas pressure regulators for inlet pressures up to 100 bar) and EN 14382 (Gas safety shut-off devices for inlet pressures up to 100 bar).

Regulators are available with inlet/outlet connections from DN25 (1") to DN50 (2").

Regulators are manufactured in three different versions in relation with outlet pressure: LP (outlet 15-160 mbar), MP (outlet 150-400 mbar) and HP (outlet 400-4000mbar). In any version components are optimized to achieve the best performances. Maximum inlet pressure is equal to 10 bar for version LP and MP; 12.5 bar for version HP.

The body of regulators are made of spheroidal graphite cast iron and covers are made of aluminum cast alloys for suitable strength with pressure.

Regulators are equipped with adjustable springs, so that outlet pressure, over pressure and under pressure can be set on site in a very precise way.

Regulators are equipped with external pulse line. Models R.3., R.34. ed R.4. have also internal pulse line for a compact installation in case of small flow. The shut off valve always needs external pulse line.

Regulators have been designed to generate low pressure drop with high flow.

Sealings are made of NBR-based rubber. Regulators are suitable for use with non-aggressive gases included in the 1, 2 and 3 families (EN 437).

All components are designed to withstand any mechanical, chemical and thermal condition occurring during typical service. Effective impregnation and surface treatments have been used to improve mechanical sturdiness, sealing and resistance to corrosion of the components.

Technical specifications

Tab. 1

Main connections	Gas threaded f/f ISO 7-1 from Rp1 to Rp2 Flanged PN16 – ISO 7005 DN25 - DN50 (on request) Gas threaded NPT ANSI-ASME B1.20 (on request) Flanged ANSI-ASA-ASME B16.5 class 150 (on request)
Connections of pulse line	Gas threaded F G1/4 ISO 228
Ambient temperature	-20°C ... +60°C
Inlet pressure	0,5 - 10 bar for version LP-MP 0,5 - 12,5 bar for version HP
Design pressure	20 bar for body(inlet) - 5 bar for cover (outlet) - DS type
Regulating class (EN334)	AG 5 / 10 depending on outlet pressure SG 20 for lock-up (+7.5mbar or +20% of set value, at least)
Shut-off class (EN14382)	Class A (under pressure and over pressure spring) Class B (only overpressure spring)
Installation	Horizontal or vertical pipeline.
Gas type	Natural gas, town gas, LPG (gaseous) of families 1,2,3 (EN437).
Materials in contact with gas	Spheroidal graphite cast iron, Aluminum, Brass, Steel, Anaerobic adhesive, Nitrile rubber (NBR), Fluoro elastomer (FPM)

Tab. 2

Regulator – spring range (mbar)		
Version	R..3 - R..34 - R..4	R..44 – R..6
LP	15-20	15-25
	20-25	25-40
	25-40	40-60
	40-60	60-80
	60-80	80-120
	80-120	120-160
MP	150-220	150-200
	220-350	200-300
	300-400	280-400
HP	380-450	380-520
	450-650	520-750
	650-850	750-1100
	850-1200	1100-2000
	1200-1800	
1800-2000		
Important note: <i>Spring of a regulator can be changed only with another spring of the same version</i>		

Tab. 3

Safety shut off valve - spring range		
Version	Over pr. (mbar)	Under pr. (mbar)
LP	40-80	6-60
	80-180	
MP	140-350	60-240
	350-450	
HP	250-400	100-150 150-500 500-1300 1300-3000
	400-800	
	700-1200	
	1200-2500	
	2500-4000	
Important note: <i>Springs of shut off valve are chosen in accordance with outlet pressure and a spring can be changed only with another of the same version</i>		

As shut off valve can work with pressure higher than that of regulator, regulator and shut off valve can have different version in accordance with table below:

Outlet pressure (mbar)	Version of regulator	Version of shut off valve
till 100 / 120	Regulator LP A1 / E	valve LP
from 100 / 120 till 300 / 350	Regulator LP F Regulator MP G - H	valve MP
higher than 300 / 350 mbar	Regulator MP L Regulator HP	valve HP

Tab. 4

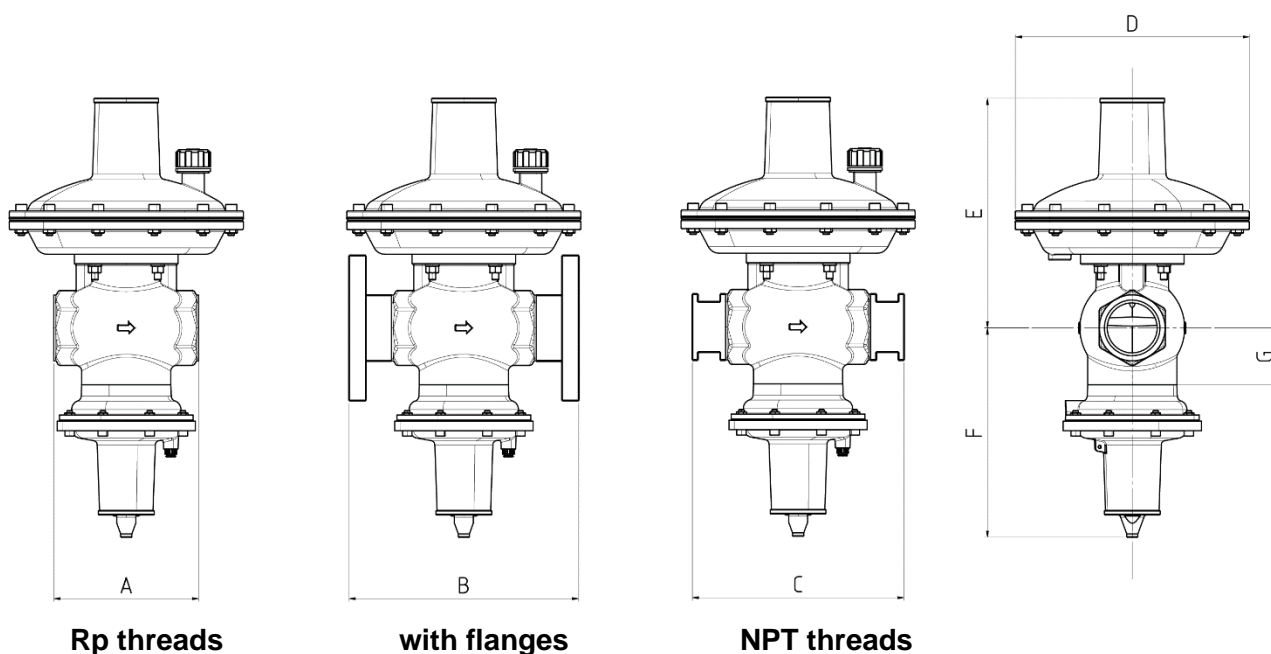

Fig. 1

Tab. 4

Model	Size	Overall dimensions [mm]							Weight model R (Kg)	Weight model RS (Kg)	Flow coefficient Cg
		A	B	C	D	E	F	G*			
R3 / RS3	1" x 1"	100	183	156	210	200	180	55	5,0 ÷ 8,0	6,5 ÷ 9,5	170
R34 / RS34	1" x 1 1/2"	130	218	186	210	210	190	65	6,0 ÷ 10	7,5 ÷ 11,5	250
R4 / RS4	1 1/2" x 1 1/2"	130	223	186	210	210	190	65	6,0 ÷ 11	7,5 ÷ 12,5	330
R44 / RS44	1 1/2" x 1 1/2"	182	223	236	300	330	215	75	14 ÷ 17,5	15,5 ÷ 19	670
R6 / RS6	2" x 2"	180	254	254	300	330	215	75	12,5 ÷ 19,5	14 ÷ 21	790

* R Regulator (without safety shut-off valve)

Selection and installation notes

To choose a pressure regulator, it is necessary to consider: inlet pressure (Pu), outlet pressure (Pd) and flow rate (Q). Tables below give the maximum flow capacity in m³/h of Natural Gas at standard conditions of absolute pressure of 1.013 bar and 15°C temperature with AC 10% and external pulse.

Conversion to LPG capacity in kg/h = multiply by 1,2 Conversion to Azote capacity = multiply by 0,789.

Tab.5

R3 / RS3 – LP : 15 - 160 mbar		1" x 1"				
		Flow Rate Q (stm ³ /h)				
Inlet pressure Pu	Pd = 20 mbar	Pd = 50 mbar	Pd = 80 mbar	Pd = 100 mbar	Pd = 120 mbar	Pd = 150 mbar
500 mbar	106	103	101	100	98	95
750 mbar	132	131	129	128	127	126
1 bar	156	155	154	154	153	152
1,5 bar	202	202	202	202	202	202
2 bar	242	242	242	242	242	242
2,5 bar	280	283	283	283	283	283
3 - 10 bar	280	290	300	300	300	310

R3 / RS3 - MP : 150 - 400 mbar		1" x 1"				
		Flow Rate Q (stm ³ /h)				
Inlet pressure Pu	Pd = 180 mbar	Pd = 200 mbar	Pd = 250 mbar	Pd = 300 mbar	Pd = 350 mbar	Pd = 400 mbar
500 mbar	92	90	84	76	67	56
750 mbar	124	122	119	115	110	105
1 bar	150	149	147	144	141	138
1,5 bar	202	202	196	194	193	191
2 bar	242	242	242	242	242	242
2,5 bar	283	283	283	283	283	283
3 bar	323	323	323	323	323	323
4 - 10 bar	325	330	340	350	370	380

R3 / RS3 - HP : 400 - 4000mbar		1" x 1"				
		Flow Rate Q (stm ³ /h)				
Inlet pressure P2	Pd = 500 mbar	Pd = 1000 mbar	Pd = 1500 mbar	Pd = 2000 mbar	Pd = 3000 mbar	Pd = 4000 mbar
750 mbar	92	-	-	-	-	-
1 bar	130	-	-	-	-	-
1,5 bar	187	149	-	-	-	-
2 bar	235	213	167	-	-	-
2,5 bar	283	265	237	183	-	-
3 bar	323	312	293	259	-	-
4 bar	403	403	390	372	298	-
5 bar	410	484	484	468	425	333
7 bar	410	540	645	645	624	586
10 bar	410	540	675	810	886	886

Tab.6

R34 / RS34 - LP : 15 - 160 mbar 1" x 1 1/2"						
Flow Rate Q (stm3/h)						
Inlet pressure Pu	Pd = 20 mbar	Pd = 50 mbar	Pd = 80 mbar	Pd = 100 mbar	Pd = 120 mbar	Pd = 150 mbar
500 mbar	155	152	149	146	144	140
750 mbar	194	192	190	189	187	185
1 bar	230	228	227	226	225	223
1,5 bar	297	297	297	297	297	297
2 bar	357	357	357	357	357	357
2,5 bar	416	416	416	416	416	416
3 bar	475	475	475	475	475	475
4 bar	593	593	593	593	593	593
5 bar	660	675	690	710	712	712
7-10 bar	660	675	690	710	720	740

R34 / RS34 - MP : 150 - 400 mbar 1" x 1 1/2"						
Flow Rate Q (stm3/h)						
Inlet pressure Pu	Pd = 180 mbar	Pd = 200 mbar	Pd = 250 mbar	Pd = 300 mbar	Pd = 350 mbar	Pd = 400 mbar
500 mbar	135	132	123	112	99	83
750 mbar	182	180	175	169	162	154
1 bar	221	220	216	212	208	203
1,5 bar	297	297	288	286	283	281
2 bar	357	357	357	357	357	357
2,5 bar	416	416	416	416	416	416
3 bar	475	475	475	475	475	475
4 bar	593	593	593	593	593	593
5 bar	712	712	712	712	712	712
7 - 10 bar	760	750	800	830	870	900

R34 / RS34 - HP : 400 - 4000 mbar 1" x 1 1/2"						
Flow Rate Q (stm3/h)						
Inlet pressure Pu	Pd = 500 mbar	Pd = 1000 mbar	Pd = 1500 mbar	Pd = 2000 mbar	Pd = 3000 mbar	Pd = 4000 mbar
750 mbar	135	-	-	-	-	-
1 bar	191	-	-	-	-	-
1,5 bar	274	220	-	-	-	-
2 bar	345	313	245	-	-	-
2,5 bar	416	390	348	269	-	-
3 bar	475	459	431	381	-	-
4 bar	593	593	574	548	439	-
5 bar	712	712	712	689	626	490
7 bar	948	948	948	948	918	862
10 bar	948	1290	1303	1303	1303	1303

Tab.7

R4 / RS4 - LP : 15 - 160 mbar		1"½ x 1"½				
		Flow Rate Q (stm3/h)				
Inlet pressure Pu	Pd = 20 mbar	Pd = 50 mbar	Pd = 80 mbar	Pd = 100 mbar	Pd = 120 mbar	Pd = 150 mbar
500 mbar	205	201	196	193	190	185
750 mbar	257	254	251	249	247	244
1 bar	303	301	299	298	297	294
1,5 bar	393	393	393	393	393	393
2 bar	471	471	471	471	471	471
2,5 bar	549	549	549	549	549	549
3 bar	627	627	627	627	627	627
4 - 10 bar	660	675	690	710	720	740

R4 / RS4 - MP : 150 - 400 mbar		1"½ x 1"½				
		Flow Rate Q (stm3/h)				
Inlet pressure Pu	Pd = 180 mbar	Pd = 200 mbar	Pd = 250 mbar	Pd = 300 mbar	Pd = 350 mbar	Pd = 400 mbar
500 mbar	179	174	162	148	131	109
750 mbar	240	238	231	223	214	203
1 bar	292	290	285	280	274	267
1,5 bar	393	393	380	377	374	370
2 bar	471	471	471	471	471	471
2,5 bar	549	549	549	549	549	549
3 bar	627	627	627	627	627	627
4 bar	760	750	783	783	783	783
5 - 10 bar	760	750	800	830	870	900

R4 / RS4 - HP : 400 - 4000 mbar		1"½ x 1"½				
		Flow Rate Q (stm3/h)				
Inlet pressure Pu	Pd = 500 mbar	Pd = 1000 mbar	Pd = 1500mbar	Pd = 2000 mbar	Pd = 3000 mbar	Pd = 4000 mbar
750 mbar	178	-	-	-	-	-
1 bar	252	-	-	-	-	-
1,5 bar	362	290	-	-	-	-
2 bar	455	414	324	-	-	-
2,5 bar	549	515	460	355	-	-
3 bar	627	607	569	502	-	-
4 bar	783	783	758	723	579	-
5 bar	939	939	939	909	826	647
7 bar	950	1252	1252	1252	1211	1137
10 bar	950	1290	1600	1720	1720	1720

Tab.8

R44 / RS44 - LP : 15 - 160 mbar		1"½ x 1"½				
		Flow Rate Q (stm3/h)				
Inlet pressure Pu	Pd = 20 mbar	Pd = 50 mbar	Pd = 80 mbar	Pd = 100 mbar	Pd = 120 mbar	Pd = 150 mbar
500 mbar	416	408	399	393	386	375
750 mbar	521	516	510	506	502	495
1 bar	615	612	608	605	602	597
1,5 bar	797	797	797	797	797	797
2 bar	956	956	956	956	956	956
2,5 bar	1080	1114	1114	1114	1114	1114
3-10 bar	1080	1115	1145	1170	1190	1220

R44 / RS44 - MP : 150 - 400 mbar		1"½ x 1"½				
		Flow Rate Q (stm3/h)				
Inlet pressure Pu	Pd = 180 mbar	Pd = 200 mbar	Pd = 250 mbar	Pd = 300 mbar	Pd = 350 mbar	Pd = 400 mbar
500 mbar	363	354	330	301	266	221
750 mbar	488	482	468	452	434	413
1 bar	592	589	579	569	557	543
1,5 bar	797	797	771	765	759	752
2 bar	956	956	956	956	956	956
2,5 bar	1114	1114	1114	1114	1114	1114
3 bar	1250	1270	1270	1270	1270	1270
4-10 bar	1250	1270	1325	1380	1430	1485

R44 / RS44 - HP : 400 - 4000 mbar		1"½ x 1"½				
		Flow Rate Q (stm3/h)				
Inlet pressure Pu	Pd = 500 mbar	Pd = 1000 mbar	Pd = 1500 mbar	Pd = 2000 mbar	Pd = 3000 mbar	Pd = 4000 mbar
750 mbar	361	-	-	-	-	-
1 bar	511	-	-	-	-	-
1,5 bar	735	589	-	-	-	-
2 bar	924	840	658	-	-	-
2,5 bar	1114	1045	934	720	-	-
3 bar	1270	1231	1156	1020	-	-
4 bar	1590	1590	1538	1468	1175	-
5 bar	1590	1907	1907	1845	1677	1313
7 bar	1590	2115	2542	2542	2460	2309
10 bar	1590	2115	2640	3165	3493	3493

Tab.9

R6 / RS6 - LP : 15 - 160 mbar		2" x 2"				
		Flow Rate Q (stm3/h)				
Inlet pressure Pu	Pd = 20 mbar	Pd = 50 mbar	Pd = 80 mbar	Pd = 100 mbar	Pd = 120 mbar	Pd = 150 mbar
500 mbar	491	481	470	463	455	442
750 mbar	614	608	601	597	592	584
1 bar	725	721	717	713	710	704
1,5 bar	940	940	940	940	940	940
2 bar	1080	1115	1127	1127	1127	1127
2,5-10 bar	1080	1115	1145	1170	1190	1220

R6 / RS6 - MP : 150 - 400 mbar		2" x 2"				
		Flow Rate Q (stm3/h)				
Inlet pressure Pu	Pd = 180 mbar	Pd = 200 mbar	Pd = 250 mbar	Pd = 300 mbar	Pd = 350 mbar	Pd = 400 mbar
500 mbar	428	417	389	355	313	261
750 mbar	575	569	552	533	511	487
1 bar	699	694	683	670	656	640
1,5 bar	940	940	909	902	895	887
2 bar	1127	1127	1127	1127	1127	1127
2,5 bar	1250	1270	1314	1314	1314	1314
3-10 bar	1250	1270	1325	1380	1430	1485

R6 / RS6 - HP : 380 - 4000 mbar		2" x 2"				
		Flow Rate Q (stm3/h)				
Inlet pressure Pu	Pd = 500 mbar	Pd = 1000 mbar	Pd = 1500 mbar	Pd = 2000 mbar	Pd = 3000 mbar	Pd = 4000 mbar
750 mbar	425	-	-	-	-	-
1 bar	603	-	-	-	-	-
1,5 bar	867	694	-	-	-	-
2 bar	1090	990	775	-	-	-
2,5 bar	1314	1233	1101	849	-	-
3 bar	1501	1452	1363	1203	-	-
4 bar	1590	1875	1814	1731	1386	-
5 bar	1590	2115	2249	2176	1977	1549
7 bar	1590	2115	2640	2997	2900	2723
10 bar	1590	2115	2640	3165	4119	4119

For calculate the flow at various conditions of installation, you can use the formulas given in EN334 (simplified calculations):

- a) If the flow's behavior is sub-critical, that is if $(p_u - p_d) \leq 0,5 * (p_u + p_a)$:

$$Q_N = \frac{13,57}{\sqrt{d * (t_u + 273)}} * C_g * \sqrt{(p_d + p_a) * (p_u - p_d)}$$

- b) If the flow's behavior is critical, that is if $(p_u - p_d) > 0,5 * (p_u + p_a)$:

$$Q_N = \frac{13,57}{\sqrt{d * (t_u + 273)}} * C_g * \frac{p_u + p_a}{2}$$

Where:

- Q_N = gas flow rate in Normal condition (Nm³/h)
(Normal condition 0°C 1,013bar - 1 Nm³/h = 1.056 stm³/h)
- d = gas relative density (see Tab. 10)
- C_g = flow coefficient (see Tab. 4)
- p_u = gas pressure at the inlet of regulator, in bar (relative value)
- t_u = gas temperature at the inlet of regulator (°C)
- p_d = gas pressure at the outlet of regulator, in bar (relative value)
- p_a = ambient atmospheric pressure (bar - absolute value – 1,013 bar generally)

Tab. 10

Gas Type	$d = \frac{\rho_{GAS}}{\rho_{AIR}}$
Natural Gas	0,61-0,66
GPL	1,55-2,00
Aria	1,00

It is advisable that real flow rate is not higher than 90% of calculated flow (values in tables already consider a safety factor of about 10% and suitable flow speed at outlet).

All regulators are set for external pulse line (fittings for external pulse available on request). Models R.3. (1"), R.34. (1"x1 1/2") and R.4. (1 1/2" standard capacity) have also internal pulse line which is suitable for flow speed until 20 m/s. For speed calculation, you can use the formula:

Tab. 11

$$V = \frac{345,9 * Q * (1 - 0,002 * p_d)}{D^2 * (1 + p_d)}$$

- V = flow speed (m/s)
- Q = gas flow rate in standard condition (stm³/h)
- D = internal pipe diameter (mm – see Tab. 11)
- p_d = outlet pressure of regulator (bar)

Tubazione	D mm
1"	28
1 1/2"	41
2"	56
2 1/2"	67
3"	80
4"	106

If external pulse line is not present, a plug G1/4 have to be screw in the connection of external pulse line. Outlet flow speed higher than 150 m/s is inadvisable.

For correct sizing of outlet pipe, consider maximum flow velocity in Tab. 12.

Tab. 12

P_d (bar)	$V_{out max}$ (m/s)
$P_d \leq 0,5$	15
$0,5 < P_d \leq 5$	25

Other recommendations for a long service life:

- always install a **filter** upstream the regulator;
- install a relief valve to discharge pressure surge due to fast shut off downstream the regulator;
- if external impulse line is necessary, connect it at a distance of at least **4xDN** from the regulator in a straight part of pipe (see fig. 2).
- install shut-off valve downstream the regulator at a distance not less than **6xDN**, to have a sufficient volume inside pipe to compensate increasing pressure when valve closes.

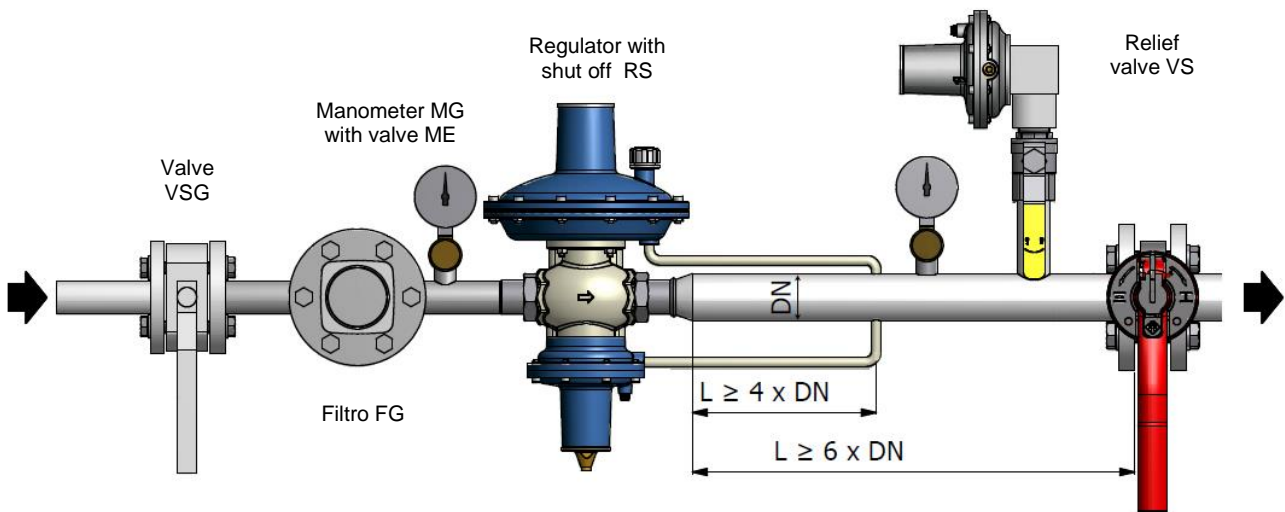

Fig.2 – example of installation with other Elektrogas devices

Ordering information

Tab. 10

	RS	4	-125	MP.L
Regulator type				
R	Gas regulator			
RS	Gas regulator with shut-off valve			
Size				
3	1" x 1"			
34	1" x 1½"			
4	1½" x 1½"			
44	1½" x 1½" (high capacity body)			
6	2" x 2"			
Connection				
none	Rp internal thread			
N	NPT internal thread			
F	ISO flanges			
NF	ANSI flanges			
Identifier of series				
-125				
Outlet pressure range (mbar)				
	R..3 - R..34 - R..4	R..44 – R..6		
LP.A1	15-20	-		
LP.A	20-25	15-25		
LP.B	25-40	25-40		
LP.C	40-60	40-60		
LP.D	60-80	60-80		
LP.E	80-120	80-120		
LP.F	120-160	120-160		
MP.G	150-220	150-200		
MP.H	220-350	200-300		
MP.L	300-400	280-400		
HP.M	380-450	380-520		
HP.O	450-650	520-750		
HP.P	650-850	-		
HP.R	850-1200	750-1100		
HP.S	1200-1800	1100-2000		
HP.T	1800-2000	-		
**				

**For higher outlet pressure contact our sales department.

Devices are supplied with following default configuration:

-outlet pressure **Pds** set in the middle of the range

-when present: underpressure **Pdsu** and overpressure **Pdso** set as table below

Pds (mbar)	Pdsu (mbar)	Pdso (mbar)
till 200	0.50 x Pds	1.75 x Pds
from 201 till 400	0.55 x Pds	1.50 x Pds
higher 400	0.60 x Pds	1.35x Pds

Tab. 14

E.g.:

RS4-125 LP.E

Regulator with shut off valve, connection Rp1½", max inlet pressure 10bar, outlet 80-120 mbar set at 100mbar, shut off in LP version with underpressure set at 50mbar and overpressure set at 175mbar.

If a different configuration is need, it has to be specified it in the order.

The information in this document contains general descriptions of technical options available and based on current specifications.

The company reserves the right to make changes in specifications and models as design improvements are introduced, without prior notice.

Elektrogas is a brand name of:
Elettromeccanica Delta S.p.A.
Via Trieste 132
31030 Arcade (TV) – ITALY
tel +39 0422 874068

www.delta-elektrogas.com
info@delta-elektrogas.com
Copyright © 2020
All rights reserved