

Measuring orifice VMO

TECHNICAL INFORMATION

- For use as a measuring or restricting orifice
- Can be combined with valVario valves and regulators
- Air and gas flow rate diagrams to facilitate configuration
- Easy installation thanks to flanges with internal thread
- Replaceable aluminium washers for optimal adjustment to local operating conditions
- Suitable for hydrogen



valVario®

Contents

Contents	2	8 Technical data	14
1 Application	3	8.1 Dimensions	15
1.1 Application examples	4	8.1.1 VMO..R	15
1.1.1 Self-recuperative burner for direct heating systems.	4	8.1.2 VMO..N	15
1.1.2 Continuous control with pneumatic ratio control system. .	4	8.1.3 VMO..F	16
1.1.3 Continuous or staged flow rate control	5	9 Maintenance cycles	17
2 Certification	6	For more information	18
2.1 Certificate download	6		
2.2 Declaration of conformity	6		
2.3 UKCA certified	6		
2.4 REACH Regulation	6		
2.5 China RoHS	6		
3 Function	7		
4 Flow rate	8		
4.1 Calculating the nominal size	8		
4.2 VMO 110, VMO 115, VMO 120, VMO 125	8		
4.3 VMO 232, VMO 240, VMO 250	9		
4.4 VMO 340, VMO 350, VMO 365	10		
5 Selection	11		
5.1 Type code	11		
5.2 ProFi	11		
6 Project planning information	12		
6.1 Installation	12		
6.2 Gas line connection	12		
6.3 Hydrogen	12		
7 Accessories	13		
7.1 Seal set VMO/VMV	13		
7.2 Washer	13		

1 Application



The valVario measuring orifice VMO is installed in gas control and safety systems, as well as in air systems used in industrial and commercial gas heat generation. It can serve as a restricting orifice when used in conjunction with valVario gas solenoid valves and gas control valves.

The test points are located in the measuring orifice housing. The measuring orifice VMO is a good-value alternative in areas where no standardized measuring orifice is required. The replaceable washers with different hole sizes allow the orifice to be adjusted perfectly to the local operating conditions.



Shaft melting furnace

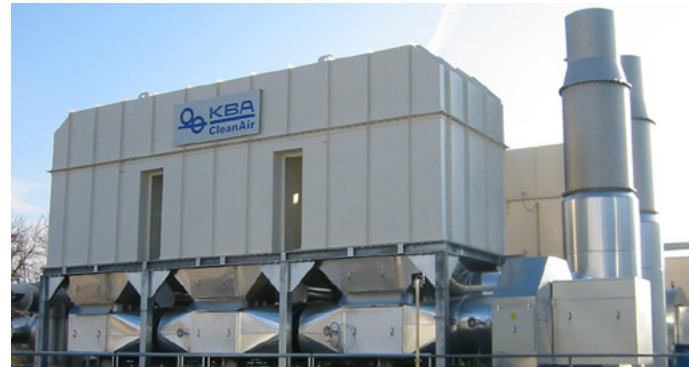

Incineration installation for thermal regenerative flue air purification

1.1 Application examples

1.1.1 Self-recuperative burner for direct heating systems

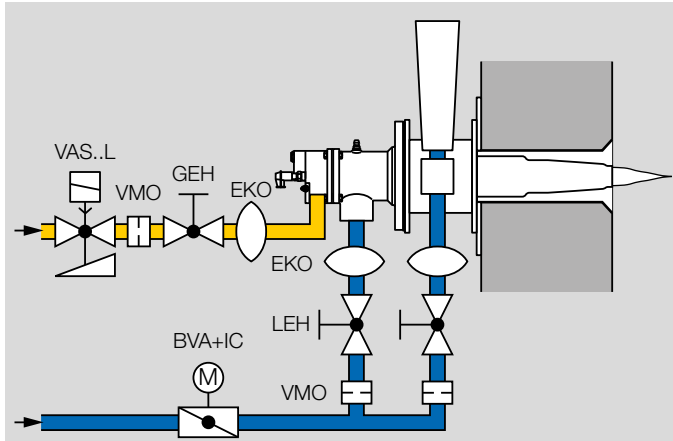

Self-recuperative burner in a direct heating system with an eductor for evacuating the flue gases from the furnace. The eductor generates a vacuum with a centrally positioned nozzle and thus draws the flue gases out of the furnace chamber through the burner's heat exchanger. The measuring orifices VMO are designed to record the gas and air flow rates.

1.1.2 Continuous control with pneumatic ratio control system

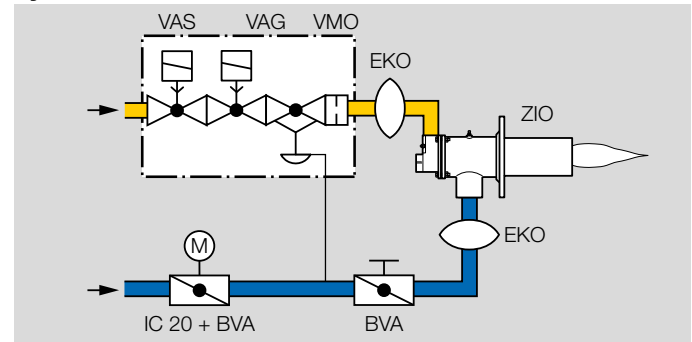

With this type of control, the mixture setting can be maintained over a wide turndown range while at the same time preventing low air pressure. This type of control is used in melting furnaces in the aluminium industry or in regenerative incineration installations in the environment industry, for example. Here, the measuring orifice VMO is designed to record the gas flow rate.

1.1.3 Continuous or staged flow rate control

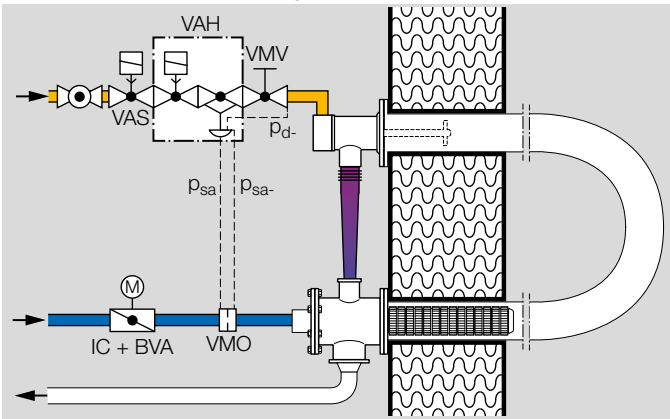

This application shows flow rate control for a tube firing burner system with plug-in recuperator for air preheating.

There are temperature-dependent air pressure losses in the recuperator. The ratio of gas pressure to air pressure does not remain constant. The fluctuating air flow rate is measured at the measuring orifice VMO and the VAH controls the gas flow rate proportionally.

The air index (lambda) can be set using the fine-adjusting valve VMV.

2 Certification

2.1 Certificate download

Certificates – see www.docuthek.com

2.2 Declaration of conformity



We, the manufacturer, hereby declare that the products VAS.../VAD/VAG/VAV/VAC/VAH/VBY/VRH/VMF/VMV/VMO with product ID No. CE-0063BO1580 comply with the requirements of the listed Directives and Standards.

Directives:

- 2014/35/EU – LVD
- 2014/30/EU – EMC
- 2011/65/EU – RoHS II
- 2015/863/EU – RoHS III

Regulation:

- (EU) 2016/426 – GAR

Standards:

- EN 161:2011+A3:2013
- EN 88-1:2011+A1:2016
- EN 126:2012
- EN 1854:2010

The relevant product corresponds to the tested type sample.

The production is subject to the surveillance procedure pursuant to Regulation (EU) 2016/426 Annex III paragraph 3.

Elster GmbH

2.3 UKCA certified



Gas Appliances (Product Safety and Metrology etc. (Amendment etc.) (EU Exit) Regulations 2019)

EN 161:2011+A3:2013, EN 88-1:2011+A1:2016, EN 126:2012, EN 1854:2010

2.4 REACH Regulation

The device contains substances of very high concern which are listed in the Candidate List of the European REACH Regulation No. 1907/2006. See Reach list HTS at www.docuthek.com.

2.5 China RoHS

Directive on the restriction of the use of hazardous substances (RoHS) in China. Scan of the Disclosure Table China RoHS2, see certificates at www.docuthek.com.

3 Function

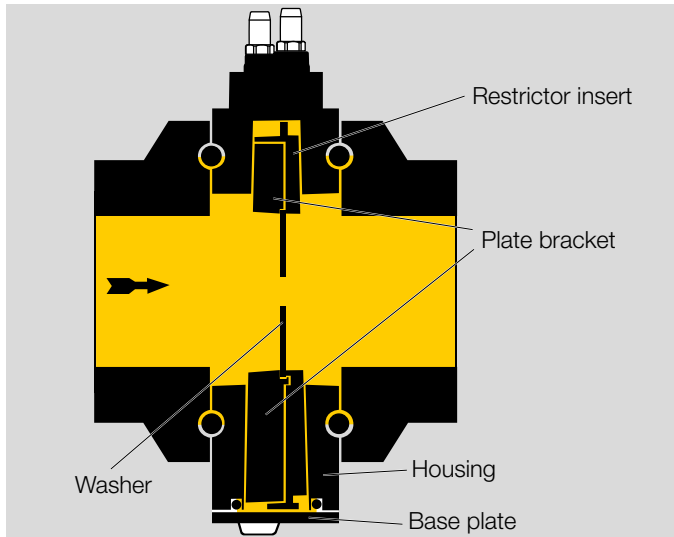

A plate bracket with a washer is placed in the VMO housing. There is a hole in the washer through which gas can flow. A circumferential seal on the restrictor insert reduces the leakage flow. For replacing the washer, the base plate of the housing can be removed in order to pull the plate bracket and washer together out of the housing.

4 Flow rate

The characteristic curves are measured at the test points at 15°C (59°F) for the individual washers with an inlet and outlet section of 5 x D, see also Project planning information.

4.1 Calculating the nominal size

A web app for calculating the nominal size is available at www.adlatus.org.

4.2 VMO 110, VMO 115, VMO 120, VMO 125

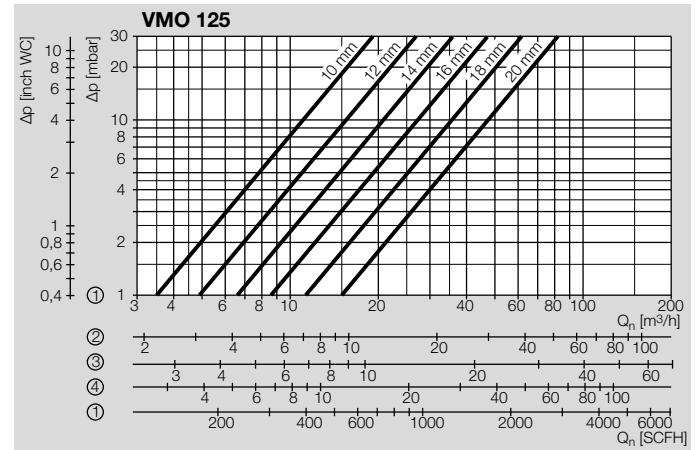
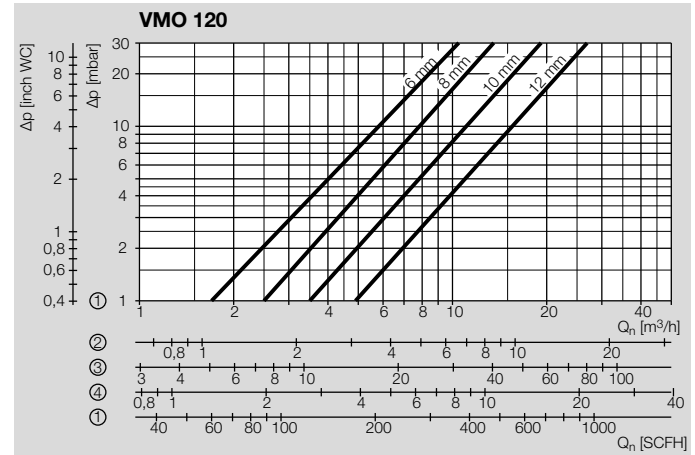
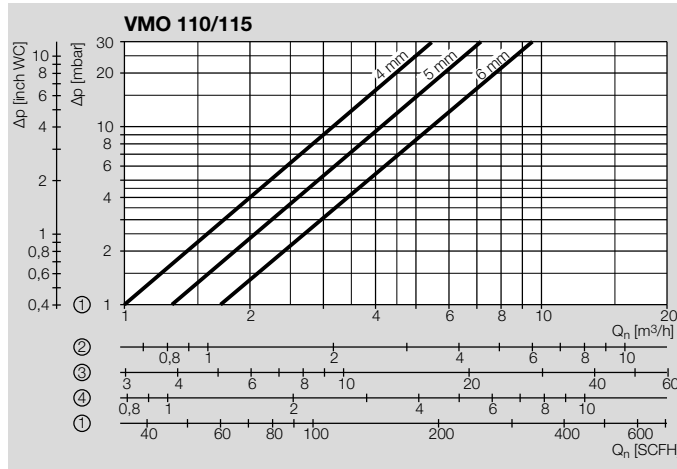

1 = natural gas ($\rho = 0.80 \text{ kg/m}^3$)

2 = propane ($\rho = 2.01 \text{ kg/m}^3$)

3 = hydrogen ($\rho = 0.09 \text{ kg/m}^3$)

4 = air ($\rho = 1.29 \text{ kg/m}^3$)

4.3 VMO 232, VMO 240, VMO 250

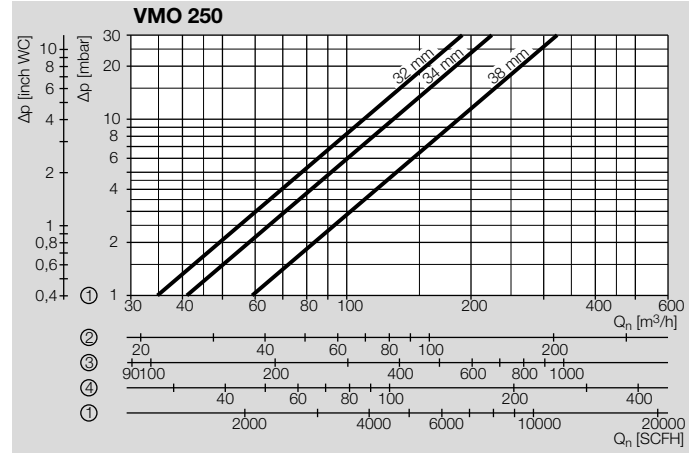
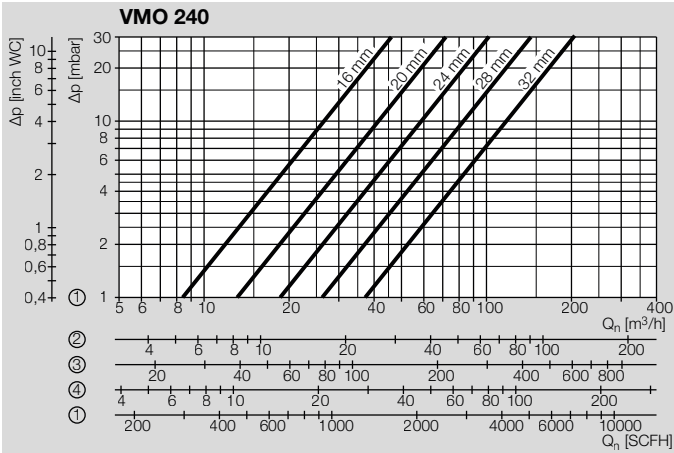
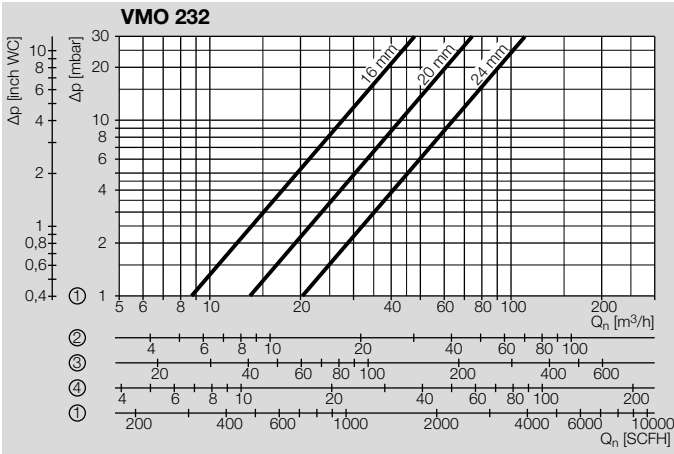

1 = natural gas ($\rho = 0.80 \text{ kg/m}^3$)

2 = propane ($\rho = 2.01 \text{ kg/m}^3$)

3 = hydrogen ($\rho = 0.09 \text{ kg/m}^3$)

4 = air ($\rho = 1.29 \text{ kg/m}^3$)

4.4 VMO 340, VMO 350, VMO 365

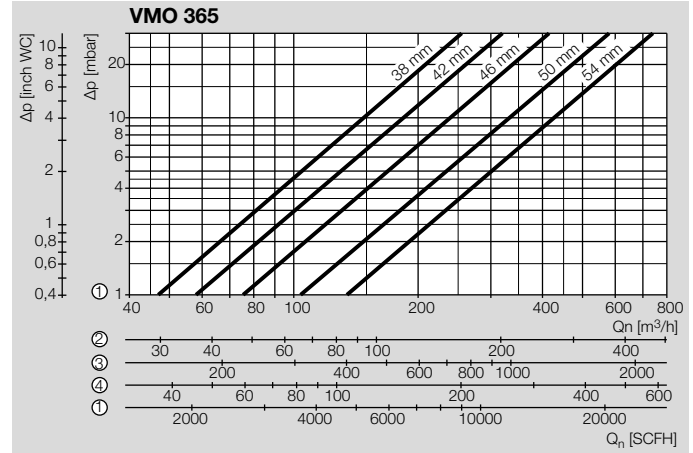
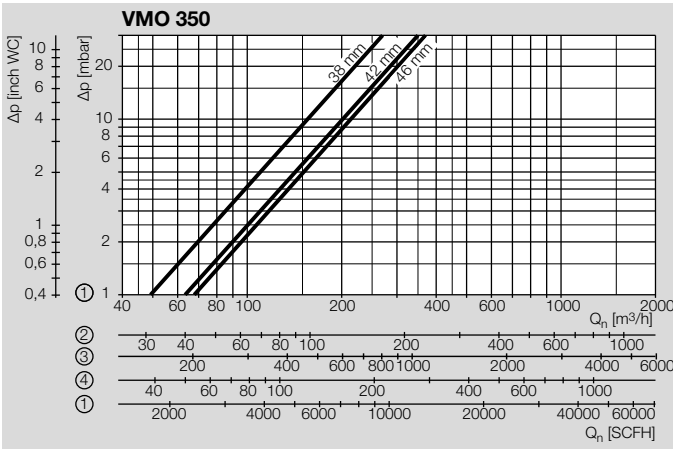
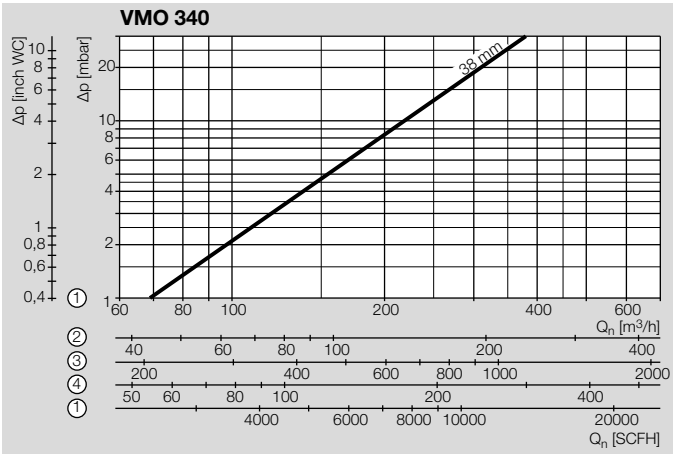

1 = natural gas ($\rho = 0.80 \text{ kg/m}^3$)

2 = propane ($\rho = 2.01 \text{ kg/m}^3$)

3 = hydrogen ($\rho = 0.09 \text{ kg/m}^3$)

4 = air ($\rho = 1.29 \text{ kg/m}^3$)

5 Selection

Option	VMO 110, VMO 115	VMO 120	VMO 125	VMO 232	VMO 240	VMO 250	VMO 340	VMO 350	VMO 365
Pipe connection	R, N	R, N	R, N	R, N	R, N, F	R, N	R, N	R, N, F	R, N
Inlet pressure	05	05	05	05	05	05	05	05	05
Pressure measuring point	M	M	M	M	M	M	M	M	M
Orifice diameter* [mm]	04, 05, 06	06, 08, 10, 12	10, 12, 14, 16, 18, 20	16, 20, 24	16, 20, 24, 28, 32	32, 34, 38	38	38, 42, 46	42, 46, 50, 54

* Delivery of washers with individual orifice diameter on request

Order example

VMO 115R05M05

5.1 Type code

VMO	Measuring orifice
1–3	Sizes
10–65	Inlet and outlet flange nominal size
R	Rp internal thread
N	NPT internal thread
F	Flange to ISO 7005
05	p_u max. 500 mbar
M	Test nipple
04–54	Orifice diameter in mm

5.2 ProFi

A web app selecting the correct product is available at www.adlatus.org.

6 Project planning information

6.1 Installation

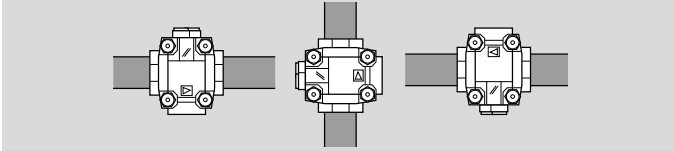

Installation position: VMO can be installed as required.

6.2 Gas line connection

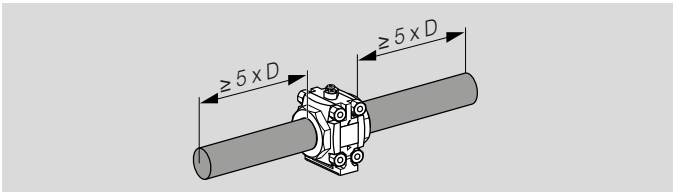

In order to take accurate measurements of the pressure differential on the measuring orifice VMO, it must be ensured that there is an undisturbed flow of gas at the inlet and outlet for a distance of $\geq 5 \times D$.

6.3 Hydrogen



Other hydrogen-compatible products can be found here: [Technical Information, Products for hydrogen.](#)

7 Accessories

7.1 Seal set VMO/VMV

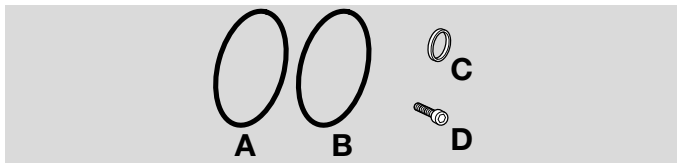

Seal set VMO/VMV 1 /B: 74924936

Seal set VMO/VMV 2 /B: 74924937

Seal set VMO/VMV 3 /B: 74926024

Scope of delivery:

- A** 1 x O-ring (baseplate)
- B** 1 x O-ring (restrictor insert)
- C** 2 x profiled sealing rings
- D** 2 x or 4 x set screws

7.2 Washer

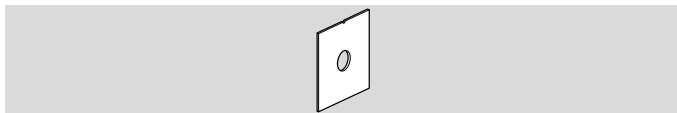

For installing in the plate bracket of measuring orifice VMO. The hole diameter is engraved on the washer. Supply including the new seal for the base plate.

Orifice	Hole dia. [mm]	Order No.
VMO1 D4 /B	4	74923803
VMO1 D5 /B	5	74923804
VMO1 D6 /B	6	74923805
VMO1 D8 /B	8	74923806

Orifice	Hole dia. [mm]	Order No.
VMO1 D10 /B	10	74923807
VMO1 D12 /B	12	74923808
VMO1 D14 /B	14	74923809
VMO1 D16 /B	16	74923810
VMO1 D18 /B	18	74923811
VMO1 D20 /B	20	74923812
VMO1 Dx /B*	xx*	74923813
VMO2 D16 /B	16	74923814
VMO2 D20 /B	20	74923815
VMO2 D24 /B	24	74923816
VMO2 D28 /B	28	74923817
VMO2 D32 /B	32	74923818
VMO2 D34 /B	34	74923819
VMO2 D38 /B	38	74923820
VMO2 Dx /B	xx*	74923821
VMO 3 D38 /B	38	74926017
VMO 3 D42 /B	42	74926018
VMO 3 D46 /B	46	74926019
VMO 3 D50 /B	50	74926020
VMO 3 D54 /B	54	74926021
VMO 3 Dx /B	xx*	74926022

* Hole diameter on request.

8 Technical data

Gas types:

natural gas, LPG (gaseous), biogas (max. 0.1 %-by-vol. H₂S), hydrogen or air; other gases on request.

The gas must be dry in all conditions and must not contain condensate.

Max. inlet pressure p_u :

500 mbar (7.25 psig).

Medium and ambient temperatures:

-20 to +60°C (-4 to +140°F), no condensation permitted.

Long-term use in the upper ambient temperature range accelerates the ageing of the elastomer materials and reduces the service life (please contact manufacturer).

Storage temperature: -20 to +40°C (-4 to +104°F).

Housing: aluminium.

Connection flanges:

with internal thread: Rp to ISO 7-1, NPT to ANSI/ASME,

with ISO flange: DN 40 and DN 50 to ISO 7005.

8.1 Dimensions

8.1.1 VMO..R

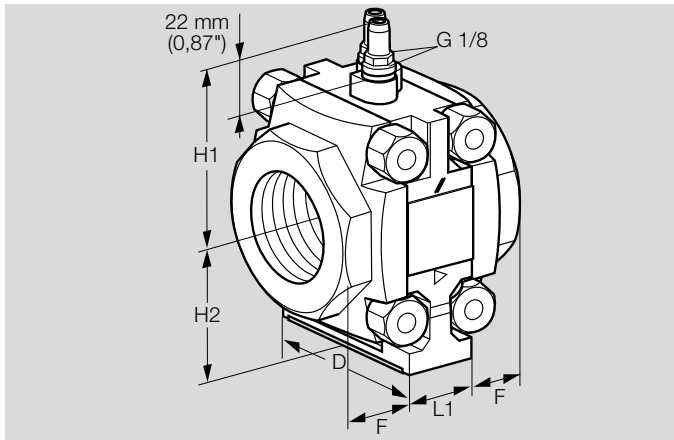

Type	Connection		Dimensions					Weight
	Rp	DN	L1	F	D	H1	H2	kg*
VMO 110	3/8	10	30	15	62.7	69.1	44.2	0.245
VMO 115	1/2	15	30	15	62.7	69.1	44.2	0.245
VMO 120	3/4	20	30	23	62.7	69.1	44.2	0.245
VMO 125	1	25	30	23	62.7	69.1	44.2	0.245
VMO 225	1	25	34	29	88	82.8	64.6	0.505
VMO 232	1¼	32	34	29	88	82.8	64.6	0.505
VMO 240	1½	40	34	29	88	82.8	64.6	0.505
VMO 250	2	50	34	29	88	82.8	64.6	0.505
VMO 340	1½	40	36	36	106	94.6	77.5	1.3
VMO 350	2	50	36	36	106	94.6	77.5	1.3
VMO 365	2½	65	36	36	106	94.6	77.5	1.3

* With flanges

8.1.2 VMO..N

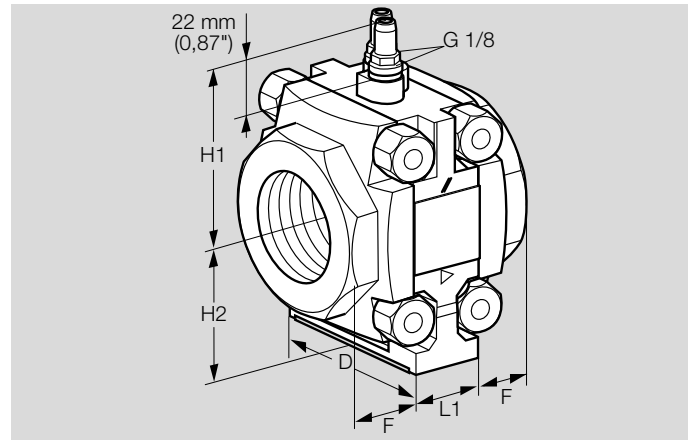

Type	Connection		Dimensions					Weight
	NPT	DN	L1	F	D	H1	H2	lbs*
VMO 110	3/8	10	1.18	0.59	2.47	2.72	1.74	0.54
VMO 115	1/2	15	1.18	0.59	2.47	2.72	1.74	0.54
VMO 120	3/4	20	1.18	0.91	2.47	2.72	1.74	0.54
VMO 125	1	25	1.18	0.91	2.47	2.72	1.74	0.54
VMO 225	1	25	1.34	1.14	3.46	3.26	2.54	1.11
VMO 232	1¼	32	1.34	1.14	3.46	3.26	2.54	1.11
VMO 240	1½	40	1.34	1.14	3.46	3.26	2.54	1.11
VMO 250	2	50	1.34	1.14	3.46	3.26	2.54	1.11
VMO 340	1½	40	1.42	1.42	4.17	3.72	3.05	2.86
VMO 350	2	50	1.42	1.42	4.17	3.72	3.05	2.86
VMO 365	2½	65	1.42	1.42	4.17	3.72	3.05	2.86

* With flanges

8.1.3 VMO..F

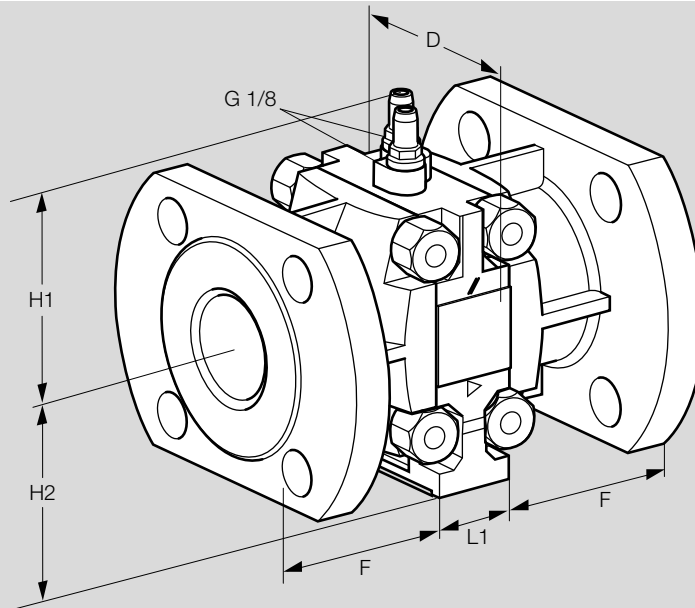

Type	Connection	Dimensions					Weight
		L1 mm	F mm	D mm	H1 mm	H2 mm	
VMO 240	40 DN	34 mm	66 mm	88 mm	81 mm	65.2 mm	0.505 kg*
VMO 350	50	36	74	106	94.6	76	1.3

* With flanges

9 Maintenance cycles

Check for external tightness at least once per annum, at least twice per annum for operation with biogas.

For more information

The Honeywell Thermal Solutions family of products includes Honeywell Combustion Safety, Eclipse, Exothermics, Hauck, Kromschroder and Maxon. To learn more about our products, visit ThermalSolutions.honeywell.com or contact your Honeywell Sales Engineer.

Elster GmbH
Strotheweg 1, D-49504 Lotte
T +49 541 1214-0
hts.lotte@honeywell.com
www.kromschroeder.com

© 2023 Elster GmbH

We reserve the right to make technical modifications in the interests of progress.

