

Linear flow control LFC

Product brochure · GB
5.1.3.10 Edition 03.08

CE

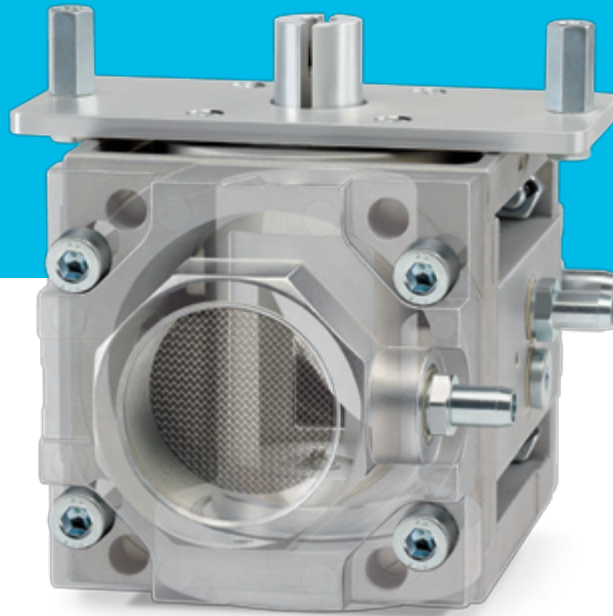

krom
schroder

- Linear behaviour between adjustment angle and flow rate
- Large control ratio of 25:1
- EC type-tested and certified
- Actuators IC 20 or IC 40 can be mounted without an adapter
- For gas and air
- Low leakage rates
- High control accuracy

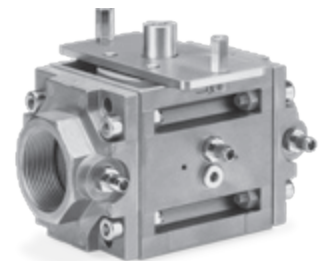

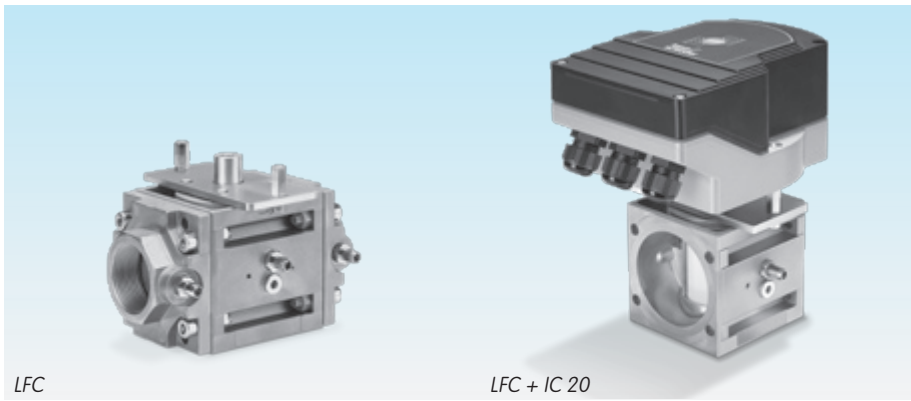

Actuator IC 20 can be mounted directly onto the linear flow control LFC.

Application

The linear flow control LFC is designed to adjust volumes of gas and cold air on various appliances. It is designed for control ratios up to 1:25, and with the mounted actuator

IC 20 or IC 40 it is suitable for regulating flow rates for modulating or stage-controlled combustion processes.

Examples of application

LFC, lambda control

If the burner is to be operated with different lambda values for process reasons,

the linear flow control LFC can be used to correct the lambda value.

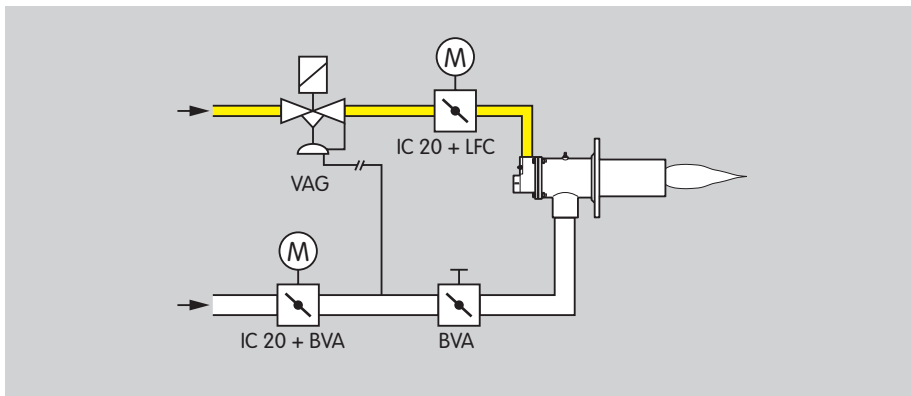

LFC, adjusting the burner output

In pneumatic systems the linear flow control with mounted actuator IC 20..E determines the air volume for the required burner output.

The butterfly valve BVA with manual adjustment is used to adjust the high-fire rate.

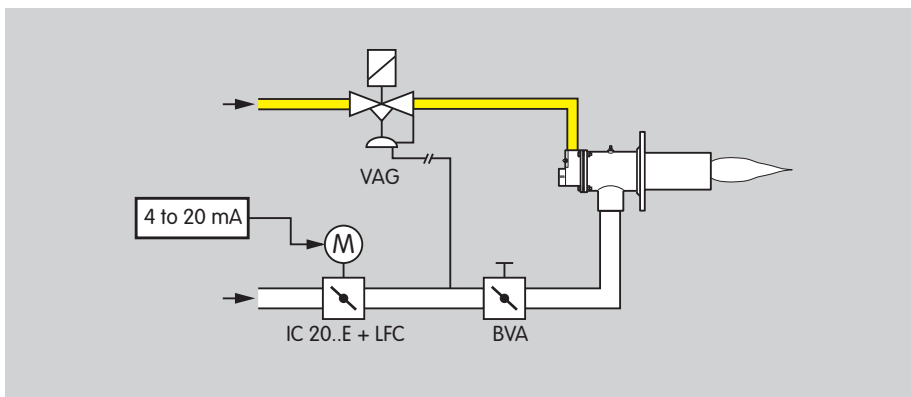

Zone control

After initiating the burner control unit, the gas solenoid valve and the linear flow control LFC open. The burner is ignited by the burner

control unit BCU. The gas flow rate can be adjusted continuously using the linear flow control with actuator IC 20. The air flow rate remains constant.

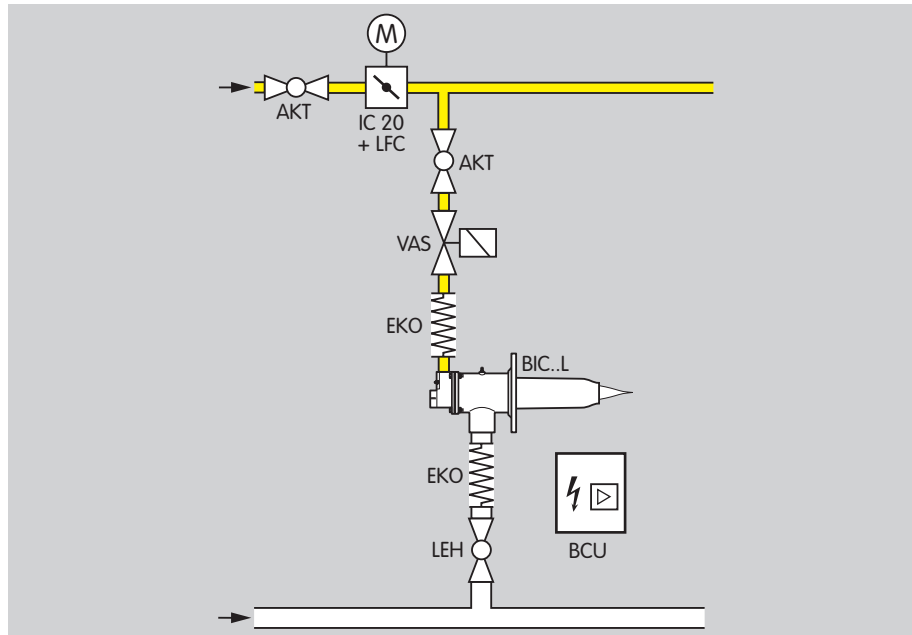

Excess air burner

After initiating the burner control unit, the linear flow control LFC moves to the ignition position. The burner is ignited by the burner control unit BCU. The gas flow rate can be

adjusted continuously using the linear flow control with actuator IC 20. The air flow rate remains constant.

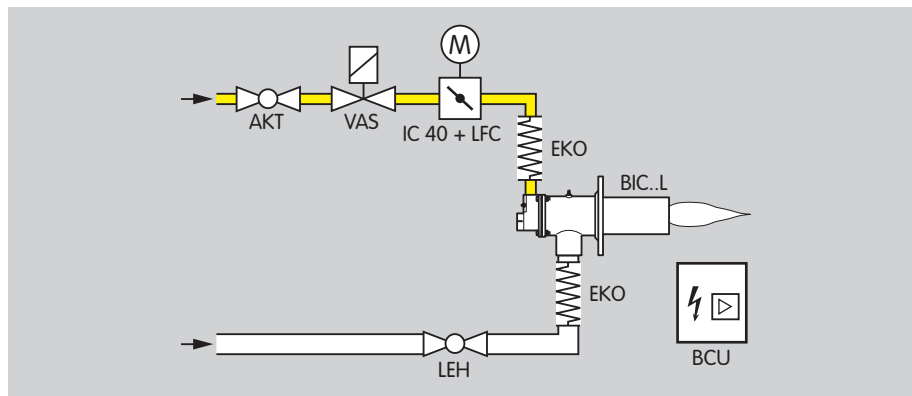

Selection

Selection table

| Type | /10* | /15* | /20* | /25* | /40* | R | ML | 05 |
|----------------|------|------|------|------|------|---|----|----|
| LFC 108 | ● | ● | ● | ● | – | ● | ○ | ● |
| LFC 115 | ● | ● | ● | ● | – | ● | ○ | ● |
| LFC 120 | ● | ● | ● | ● | – | ● | ○ | ● |
| LFC 232 | – | – | – | ● | ● | ● | ○ | ● |

* Only in conjunction with Rp internal thread.

● = standard, ○ = available

Order example

LFC 115/20R05

Type code

| Code | Description |
|------------------------------|-------------------------------------|
| LFC | Linear flow control |
| 104...232 | Series |
| /10.../40 | Connection flange nominal diameter* |
| R | Rp internal thread |
| ML | Module |
| p _e max. 500 mbar | 05 |

* If "none", this specification is omitted.

Technical data

Gas type:

natural gas, town gas, LPG (gaseous) and air.

Control ratio: 25:1.

Leakage rate: < 2% of k_{V5} value.

Max. inlet pressure p_e: 500 mbar.

Running times: 7.5 s, 15 s, 30 s, 60 s.

Connection flanges: Rp internal thread pursuant to ISO 7-1.

Housing material: aluminium,

Control cylinder: POM.

Ambient temperature:

-20 to +60°C.

Installation position: any.

Certification



The linear flow control LFC is EC type-tested and certified pursuant to

- Gas Appliances Directive (90/396/EEC) on the basis of EN 13611/EN 161.

Detailed information on this product

www.docuthek.com

Contact

www.kromschroeder.com → Sales

Elster GmbH
Postfach 2809 · 49018 Osnabrück
Strothweg 1 · 49504 Lotte (Büren)
Germany

T +49 541 1214-0
F +49 541 1214-370
info@kromschroeder.com
www.kromschroeder.com
www.elster.com

Kromschroeder, a product
brand of the Elster Group

**krom
schroeder**

We reserve the right to make technical modifications
in the interests of progress.

Copyright © 2007 Elster Group
All rights reserved.