



BCU 560, BCU 565



ERC PL SIL CE

## Burner control units

- For monitoring and controlling modulating or staged burners for multiple burner applications with a central air supply
- For directly ignited burners of unlimited capacity in intermittent or continuous operation
- Optionally with valve proving system
- Optionally with menox<sup>®</sup> operating mode to reduce the formation of thermal NOx
- Flexible range of applications due to parameterization possibilities
- PROFINET fieldbus connection using optional bus module
- Assume safety functions pursuant to EN 746-2
- EU certified
- Certified for systems up to SIL 3 and PL e

## Application



*Burner control unit with plug-in spring force connection terminals*

Burner control units BCU 560 or BCU 565 control, ignite and monitor gas burners in intermittent or continuous operation. They can be used for directly ignited industrial burners of unlimited capacity. The burners may be modulating-controlled or stage-controlled. Their fast reaction to various process requirements makes the BCUs suitable for frequent cycling operation.

On industrial furnaces, they reduce the load on the central furnace control by taking over tasks that relate to the burner, for example they ensure that the burner ignites in a safe condition when it is restarted.

The air control on the BCU..F1, F2 or F3 assists the furnace control for cooling, purging and capacity control tasks.

The burner control units have an interface via which an air valve or actuator (IC 20, IC 40 or RBW) can be controlled for staged or modulating burner capacity control.

The BCU 565..F3 is equipped with air flow monitoring and pre- and post-ventilation for use on self recuperative burners.

The program status, the unit parameters and the level of the flame signal can be read directly from the unit. The burner or a connected control element can be activated manually using the integrated Manual mode for setting and diagnostic purposes.

Thanks to the optionally integrated valve proving system, the valves can be checked for leaks by querying an external gas pressure switch or it can be checked whether the gas valve on the inlet side is closed.

Using the BCSOft program, the parameters, analysis and diagnostic information can be read from a BCU via the optionally available opto-adapter. All valid parameters are saved on an integrated parameter chip card. The parameter chip card can be removed from the old unit and inserted into a new BCU to transfer the parameters, for example when replacing the unit.

The monitored outputs for the actuator and valves are accommodated in a plug-in power module. This can simply be replaced if necessary.



*Once the plug-in power module has been removed, the parameter chip card and fuses are accessible.*

The BCU can be installed on a DIN rail in the control cabinet. Plug-in connection terminal strips on the BCU make it easier to install and remove.



*Thanks to the operator-control unit OCU, display functions and operation of the BCU can be relocated to the control cabinet door.*

The external operator-control unit OCU is available as an option for the burner control units. The OCU can be installed in the control cabinet door instead of standard control units. The program status or fault messages can be read on the OCU. For burner adjustment, the operating points can be approached conveniently in Manual mode using the operator-control unit.



*The address for the fieldbus communication is set using three code switches.*

The optional bus module BCM 500 makes it possible to connect the BCU to a fieldbus interface in a PROFINET network. Networking via the fieldbus enables multiple BCUs to be controlled and monitored by an automation system (e.g. PLC). The bus module is prepared for DIN rail installation. It is pushed on to the BCU from the side.

## Examples of application

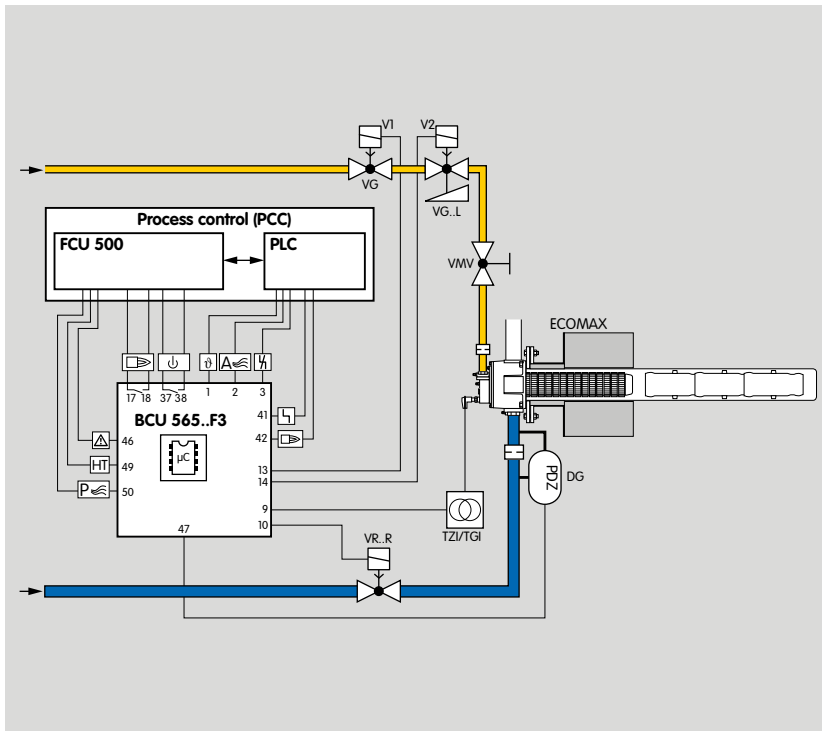

### Single-stage-controlled burner

Control: ON/OFF.

The gas/air mixture is adjusted to the requirements of the applications using the parameters of pre-ventilation and post-ventilation. The pressure switch monitors the air flow in the air supply line or in the flue gas exhaust.

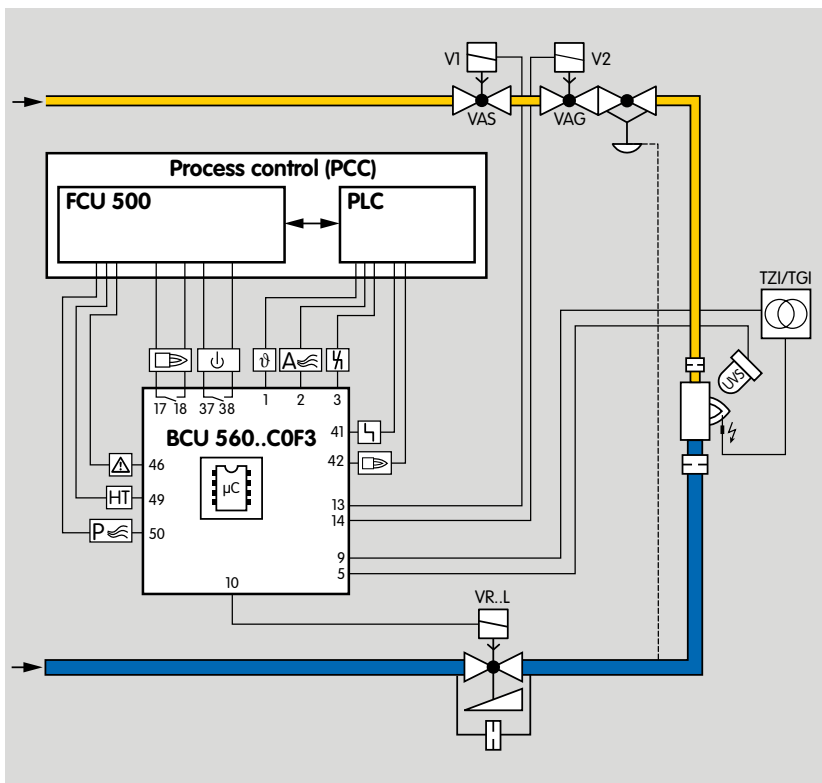

### Two-stage-controlled burner

Control:

ON/OFF or High/Low

The BCU provides the cooling and purging processes. The burner starts at low-fire rate. When the operating state is reached, the BCU advises the control unit. Depending on the parameter setting, the air valve is actuated to open and close by the program or externally via the input at terminal 2.

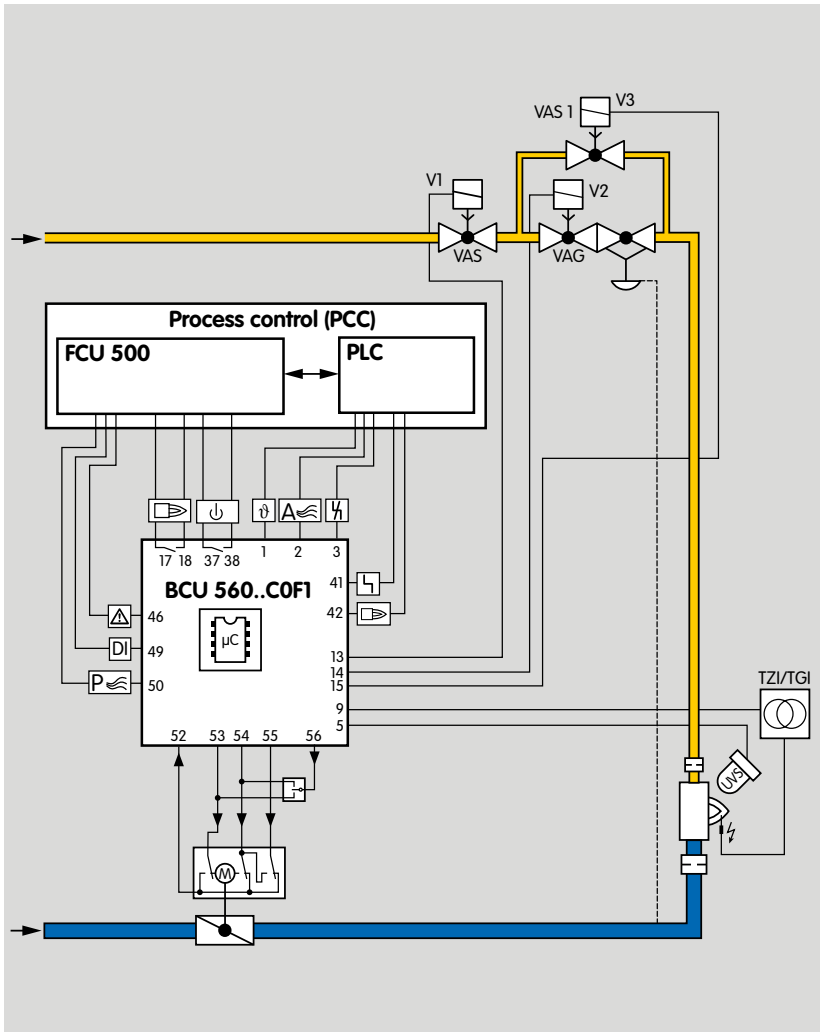

## Modulating-controlled burner

Control: continuous

The BCU provides the cooling and purging processes. The BCU moves the butterfly valve for air to ignition position. The burner starts at low-fire rate, a three-point step controller controls the burner capacity via the butterfly valve for air after the operating state has been signalled.

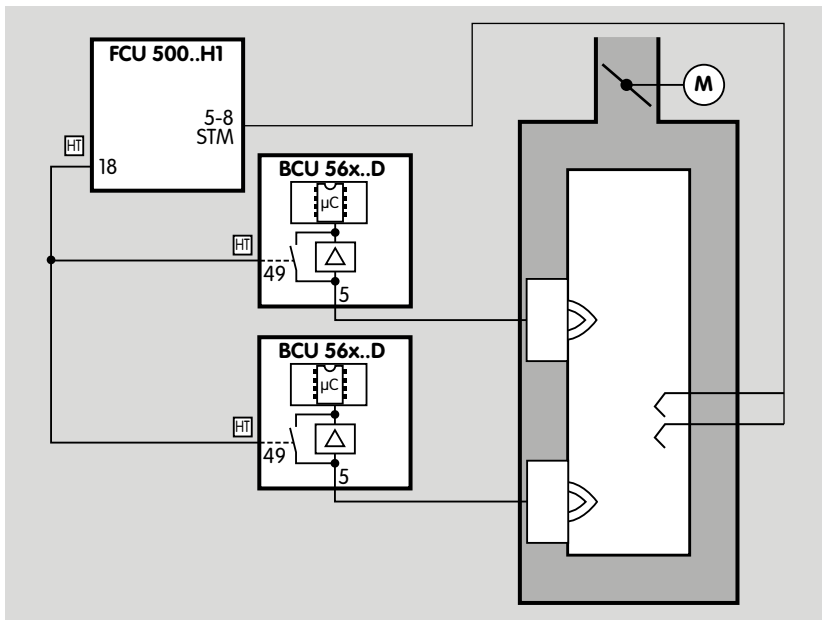

## Flame control using the temperature

In high temperature systems (temperature  $> 750^{\circ}\text{C}$ ), the flame may be controlled indirectly via the temperature. As long as the temperature in the furnace chamber is below  $750^{\circ}\text{C}$ , the flame must be controlled by conventional methods.

If the temperature in the furnace chamber rises above the spontaneous ignition temperature of the gas/air mixture ( $> 750^{\circ}\text{C}$ ), the FCU signals to the burner control units via the fail-safe HT output that the furnace system is in High temperature mode (HT). When the HT input is activated, the burner control units switch to High temperature mode. They operate without evaluating the flame signal and their internal flame control is non-functional.

If the furnace temperature falls below the spontaneous ignition temperature ( $< 750^{\circ}\text{C}$ ), the FCU disconnects the HT output from the electrical power supply. There is no longer an active signal at the HT inputs of the burner control units. The flame signals are monitored once again by the UV sensor or ionization electrode.

In the event of a fault in a temperature monitoring component (e.g. sensor discontinuity, sensor short-circuit) or in the event of a mains failure, the flame control task is transferred to the burner control units.

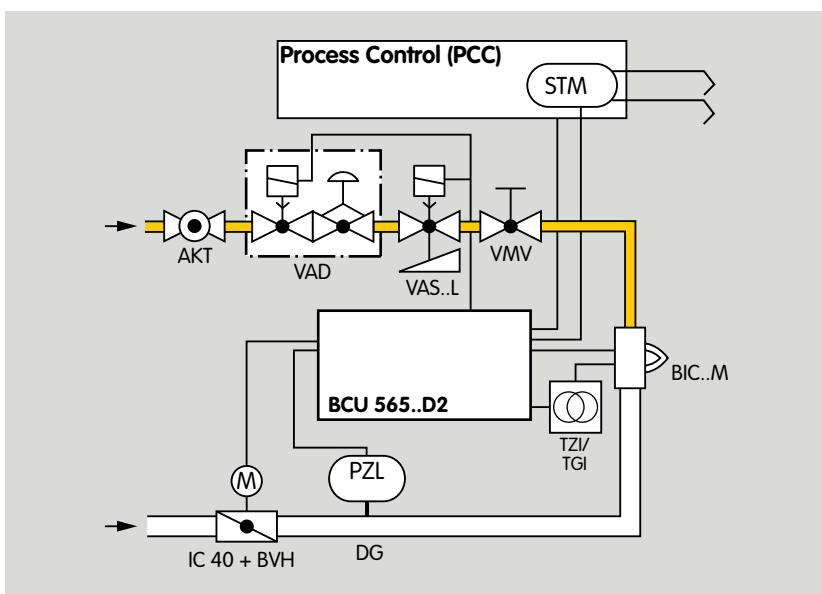

## menox<sup>®</sup> mode to reduce NO<sub>x</sub> formation

The burner control unit BCU 565 switches the burner BIC..M ON/OFF in cycles. Burner BIC..M is controlled without pneumatic air/gas ratio control system. The gas supply pressure is controlled by the gas pressure regulator VAD; the required burner capacity is set using the fine-adjusting valve VMV. The capacity is controlled by actuator IC 40 and butterfly valve BVH. An air pressure switch upstream of the burner monitors the functioning of the butterfly valve. In addition, air/gas ratio monitoring for the zone or the furnace is required.

As soon as the safety temperature monitor STM signals a furnace temperature of  $\geq 850^{\circ}\text{C}$  ( $1562^{\circ}\text{F}$ ), the burner can be switched to flameless combustion (menox<sup>®</sup> low NO<sub>x</sub> mode) to significantly reduce NO<sub>x</sub> emissions.

Switching to menox<sup>®</sup> low NO<sub>x</sub> mode eliminates the counterpressure by the flame in the ceramic tube TSC. At a constant gas supply pressure, the gas volume increases by approximately 15%. In menox<sup>®</sup> low NO<sub>x</sub> mode, the butterfly valve moves to a smaller open position which has been adapted to the pressure ratios.

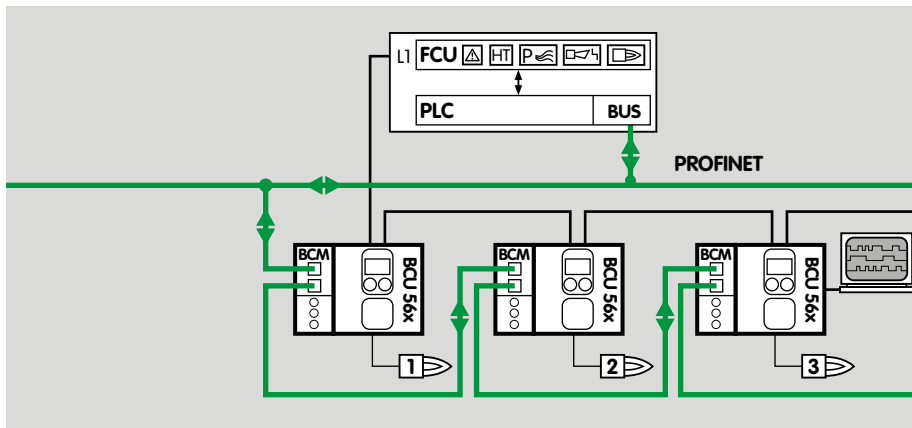

## PROFINET connection using bus module BCM

The bus system transfers the control signals from the automation system (PLC) to the BCU/BCM for starting, resetting, controlling the air valve, purging the furnace or for cooling and heating during operation. In the opposite direction, it sends operating status, the level of the flame signal and the current program status.

Control signals that are relevant for safety, such as the safety interlocks, purge and HT input, are transferred independently of the bus communication by separate cables.

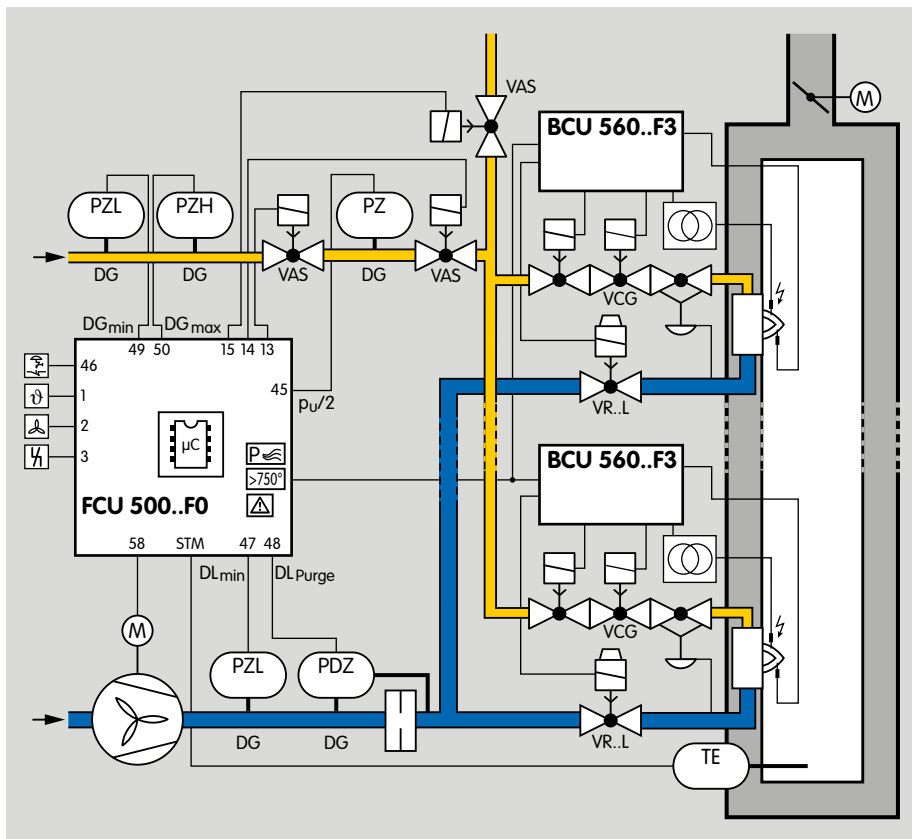

## ON/OFF rotary impulse control for burners up to 360 kW

For processes which require a turn-down of more than 10:1 and/or those which require heavy circulation of the furnace atmosphere to ensure a uniform temperature, e.g. heat treatment furnaces operating at low and medium temperatures in the metallurgical industry.

With ON/OFF cyclic control, the capacity supplied to the process is controlled by means of a variable ratio of the operating time to the pause time. In this type of control, the burner output pulse frequency always maintains full momentum and results in maximum convection in the furnace chamber, even with regulated heating.

The pneumatic ratio control system controls the gas pressure on the burner proportionally to the air pressure and thus maintains a constant air/gas ratio. At the same time, it acts as a low air pressure protection device.

The ignition and monitoring of the individual burners is ensured by burner control unit BCU 560.

The centrally checked safety functions such as pre-purge, tightness test, flow detector and pressure switch check ( $gas_{min.}$ ,  $gas_{max.}$ ,  $air_{min.}$ ) are provided by the FCU 500.

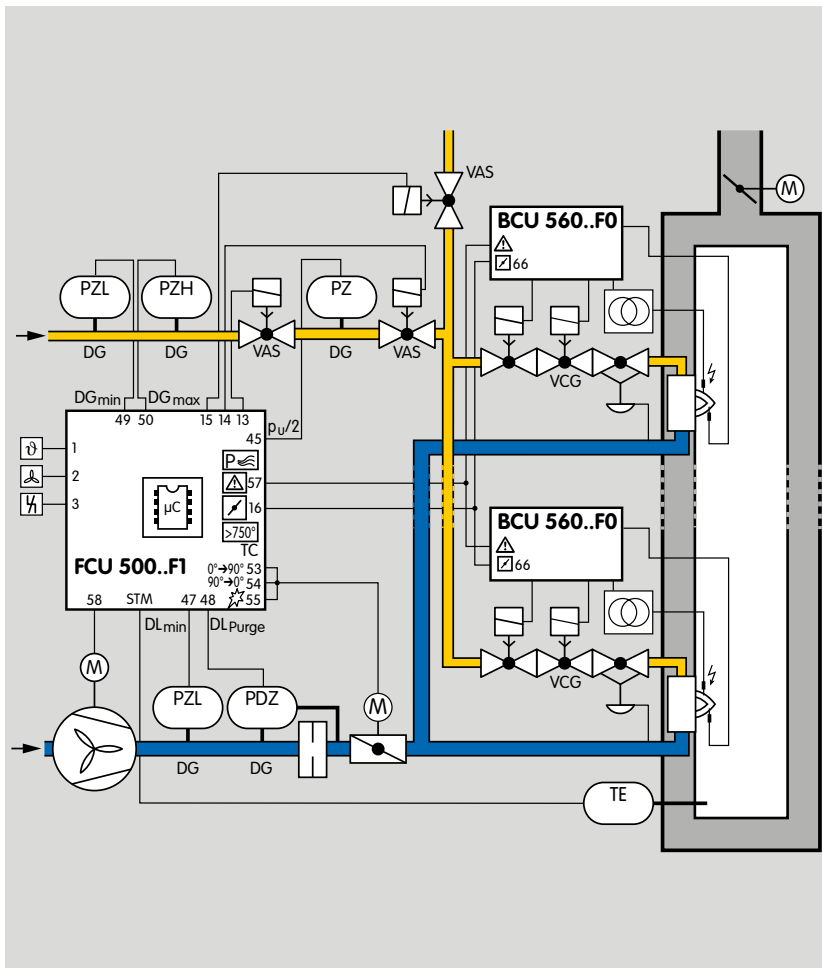

## ON/OFF rotary impulse control for burners up to 360 kW

For processes which require a turndown of more than 10:1 and/or those which require heavy circulation of the furnace atmosphere to ensure a uniform temperature, e.g. heat treatment furnaces operating at low and medium temperatures in the metallurgical industry.

With ON/OFF cyclic control, the capacity supplied to the process is controlled by means of a variable ratio of the operating time to the pause time. In this type of control, the burner output pulse frequency always maintains full momentum and results in maximum convection in the furnace chamber, even with regulated heating.

The pneumatic ratio control system controls the gas pressure on the burner proportionally to the air pressure and thus maintains a constant air/gas ratio. At the same time, it acts as a low air pressure protection device.

The ignition and monitoring of the individual burners is ensured by burner control unit BCU 560.

The centrally checked safety functions such as pre-purge, tightness test, flow detector and pressure switch check ( $gas_{min.}$ ,  $gas_{max.}$ ,  $air_{min.}$ ) are provided by the FCU 500.

## Type code

Code	Description
BCU	Burner control unit
560 565	Series 560 Series 565
Q W	Mains voltage: 120 V AC, 50/60 Hz 230 V AC, 50/60 Hz
C0 C1	No valve proving system With valve proving system
F0 F1 F2 F3	Capacity control: none with interface for actuator IC with interface for RBW actuators with air valve control
U0	Ionization or UV control in case of operation with gas
D0 D1 D2	Digital input: none for high temperature operation for menox®
K0 K1 K2	No plug-in terminals Plug-in terminals with screw connection Plug-in terminals with spring force connection
E	Individual packaging

## Technical data

### Mains voltage

BCU..Q: 120 V AC, -15/+10%, 50/60 Hz, ±5%,  
BCU..W: 230 V AC, -15/+10%, 50/60 Hz, ±5%,  
for grounded or ungrounded mains.

### Power consumption:

At 230 V AC approx. 6 W/11 VA plus power consumption per AC input of approx. 0.15 W/0.4 VA, at 120 V AC approx. 3 W/5.5 VA plus power consumption per AC input of approx. 0.08 W/0.2 VA.

### Flame control:

With UV sensor or ionization sensor, for continuous operation (intermittent operation with UVS).

### Flame signal current:

ionization control: 2 – 25 µA,  
UV control: 5 – 25 µA.

### Signal cable for flame signal current:

max. 100 m (164 ft).

### Weight: 0.7 kg.

### Ambient temperature:

-20 to +60°C (-4 to +140°F),  
no condensation permitted.

### Enclosure: IP 20 pursuant to IEC 529.

## Maintenance

The fail-safe outputs (valve outputs V1, V2 and V3) of the power module are monitored for correct functioning. In the event of a fault, the system is set to a safe status using a second shutdown method (isolation of the valve outputs from the mains). In the event of a defect (e.g. fault 36), the power module must be replaced.

See [www.partdetective.de](http://www.partdetective.de) (optimized for smartphones) for a replacement/order option for the power module.

The device and user statistics can be displayed using the operator-control unit OCU or engineering tool BCSoft for further diagnostics and troubleshooting. The user statistics can be reset using engineering tool BCSoft.

## Technical Information bulletin for this product

[www.docuthek.com](http://www.docuthek.com)  
Search term:  
BCU 560, BCU 565

## Contact

[www.kromschroeder.com](http://www.kromschroeder.com) → Process Heat → Sales  
Elster GmbH  
Strothweg 1 · 49504 Lotte (Büren)  
Germany  
Tel. +49 541 1214-0  
[hts.lotte@honeywell.com](mailto:hts.lotte@honeywell.com)  
[www.kromschroeder.com](http://www.kromschroeder.com)

We reserve the right to make technical modifications in the interests of progress.  
Copyright © 2017 Elster GmbH  
All rights reserved.

**Honeywell**  
**kromschroeder**