

Pilot burner ZKIH

Technical Information · GB
7 Edition 03.16l



- Diverse possible applications thanks to splash-proof connection housing
- Pilot burner with forced air supply
- Simple conversion of gas types from natural gas to LPG or town gas
- Reliable electrical ignition thanks to ignition electrode
- Safe flame control thanks to ionization electrode
- Different lengths make it suitable for many installation situations

Contents

Pilot burner ZKIH	1
Contents	2
1 Application	3
1.1 Examples of application	4
1.1.1 On/Off control	4
1.1.2 Igniting a main burner	4
2 Certification	5
3 Function	6
4 Selection	7
4.1 Type code	7
5 Project planning information	8
5.1 Installation	8
5.2 Gas/air line connection	8
6 Accessories	9
6.1 Ignition transformer	9
6.2 Adapter set	9
6.3 Pressure regulators	9
7 Technical data	10
7.1 Dimensions	11
7.1.1 ZKIH	11
7.1.2 ZKIHB	12
7.2 Converting units	13
8 Maintenance cycles	14
Feedback	15
Contact	15

1 Application

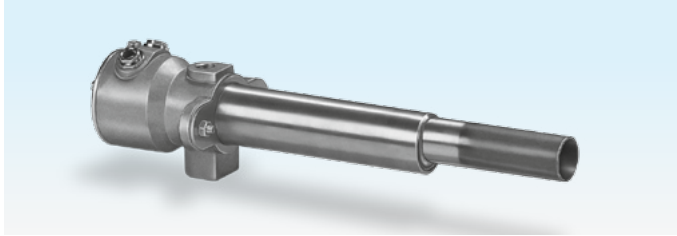

Pilot burner ZKIH with splash-proof connection housing

For use as a pilot burner for safe ignition of main burners in industrial furnaces and firing systems in the iron and steel industries in the precious, non-ferrous and light metal sector, as well as in the plastics, fibre and paper industries. Can also be used as an independently operated burner for applications requiring a burner capacity of 2 to 7 kW (for natural gas max. 5 kW).

The pilot burner is available in different lengths. It has a splash-proof housing. On delivery, the burner is equipped for operation with natural gas. It can easily be converted for operation with LPG or town gas.

Burner ZKIHB is used for the ignition of high-speed burners.



Flame of the ZKIH during natural gas operation in the open air

1.1 Examples of application

1.1.1 On/Off control

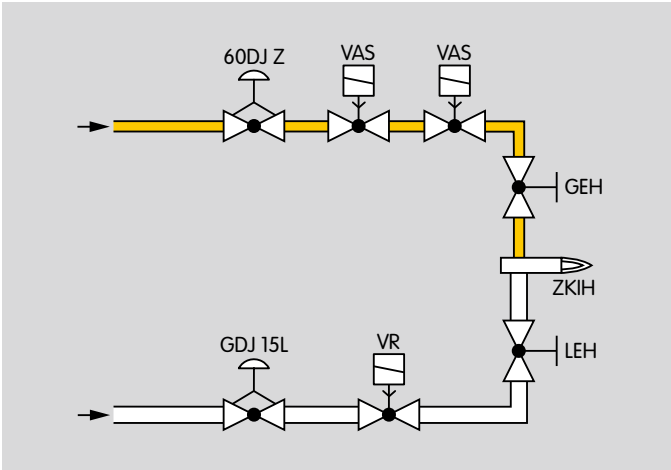

The gas/air mixture is set using the gas adjusting cock GEH and the air adjusting cock LEH. For a constant mixture of gas and air (λ), one pressure regulator per burner is used in the gas and air circuits.

1.1.2 Igniting a main burner

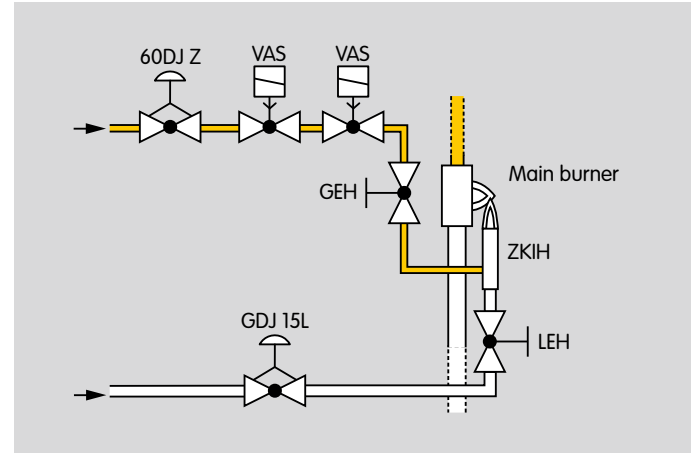

Install the pilot burner so that reliable ignition of the main burner is guaranteed.

2 Certification

Certificates – see Docuthek.

Eurasian Customs Union



The product ZKIH meets the technical specifications of the Eurasian Customs Union.

Declaration of Incorporation pursuant to the Machinery Directive

The ZKIH complies with the requirements of EN 746-2 and the Machinery Directive 2006/42/EC. This is confirmed by the manufacturer's Declaration of Incorporation.

3 Function

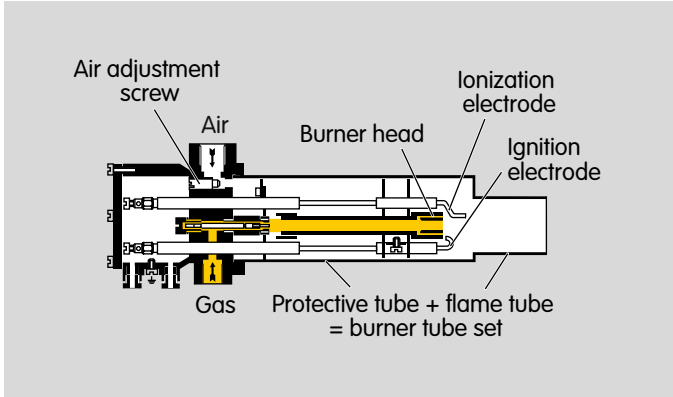

The burner control unit opens the gas and air control valves. Gas flows through the gas connection and air flows through the air connection in the burner housing as far as the burner head.

The combustible gas/air mixture is produced downstream of the burner head. The gas/air mixture is electrically ignited directly by an ignition electrode. A flame forms which is monitored using an ionization electrode.

4 Selection

	150	180	200	230	300	330	400	430	500	530	600	630	700	730	800	830	900	930	/100	R	
ZKIH	●	-	●	-	●	-	●	-	●	-	●	-	●	-	●	-	●	-	●	●	●
ZKIHB	-	●	-	●	-	●	-	●	-	●	-	●	-	●	-	●	-	●	-	●	●

Order example

ZKIHB 180/100R

4.1 Type code

Code	Description
ZKIH	Pilot burner with forced air supply
ZKIHB	For ignition of high-speed burners
150 - 930	Protective tube length ¹⁾ [mm] 150 to 930
/100	Flame tube length [mm] 100
R	Rp internal thread

¹⁾ Longer lengths on request.

5 Project planning information

5.1 Installation

Install and insulate the pilot burner in order to avoid any overheating of the components during operation. Where applicable, purging air must be used to prevent ingress of aggressive gases and thermal overload of components.

When a pilot burner is installed in a burner quarl, the burner tube set can be subjected to very high thermal stress. A means of cooling the pilot burner must always be provided. Air must constantly be passed through a 3 mm gap on the outside of the protective tube. As a result of this measure, the service life of the pilot burner can be significantly increased.

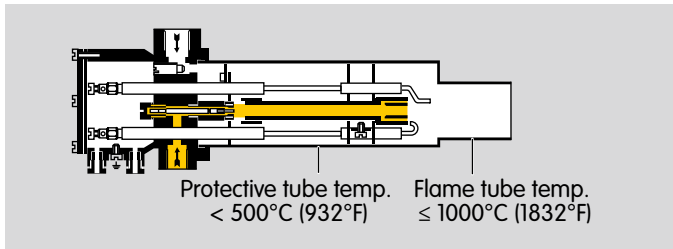

The tip of the pilot burner flame tube must not come into contact with the main burner flame. Safe ignition of the main burner must be ensured.

When the pilot burner is switched off, the pilot burner air should continue to flow to ensure that the pilot burner is cooled.

5.2 Gas/air line connection

A gas test point and an air test point must be provided by the customer upstream of the ZKIH to measure the gas and air pressure respectively.

6 Accessories

6.1 Ignition transformer

To ensure safe ignition, we recommend using ignition transformer TGI 5-15/100W or TZI 5-15/100W.



TGI 5-15/100W



TZI 5-15/100W

6.2 Adapter set

For connecting the pilot burner ZKIH to pilot gas and air lines. Comprising one adapter with 1/4-18 NPT internal thread and one adapter with 1/2-14 NPT internal thread.

Order No. 74923430

6.3 Pressure regulators

For a constant mixture of gas and air (λ), we recommend using one pressure regulator 60DJ Z in the gas circuit and one pressure regulator GDJ 15L in the air circuit per burner.

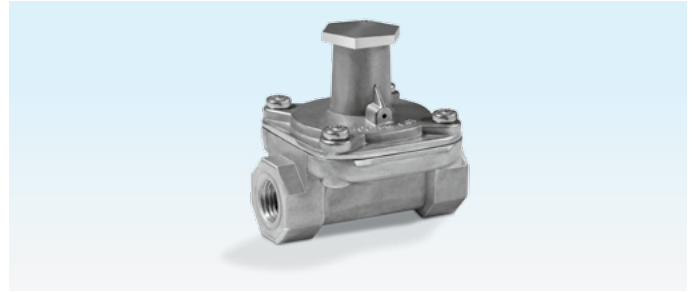

60DJ Z, DN 8



GDJ 15L, DN 15

7 Technical data

Burner	Capacity	
	kW	1000 BTU/h
ZKIH	2 – 7	7.6 – 26
with natural gas	max. 5	max. 17

Gas types:

natural gas, LPG (gaseous) and coke oven gas.

Gas inlet pressure: 5 to approx. 50 mbar

(2 to approx. 20 "WC),

air inlet pressure: 5 to approx. 40 mbar (2 to approx.

16 "WC),

each depending on the gas type

(burner pressures – see www.docuthek.com,

Kind of document: Operating characteristic diagram).

On delivery: natural gas setting (gas and air pressures:

15 mbar (6 "WC)).

For cold air only.

Flame control: with ionization electrode.

Ignition: direct spark ignition (5 kV ignition transformer).

Housing: aluminium.

Protective tube: stainless steel.

Flame tube: heat-resistant steel.

Max. temperature at the tip of the flame tube:

< 1000°C (< 1832°F),

< 900°C (< 1652°F) for $\lambda < 1$.

Max. temperature of the protective tube: 500°C

(932°F).

Gas and air pressures:

see burner diagram at www.docuthek.com,

Kind of document: Operating characteristic diagram.

Flame length at rated capacity: approx. 25 cm (9.8").

Control: On/Off.

7.1 Dimensions

7.1.1 ZKIH

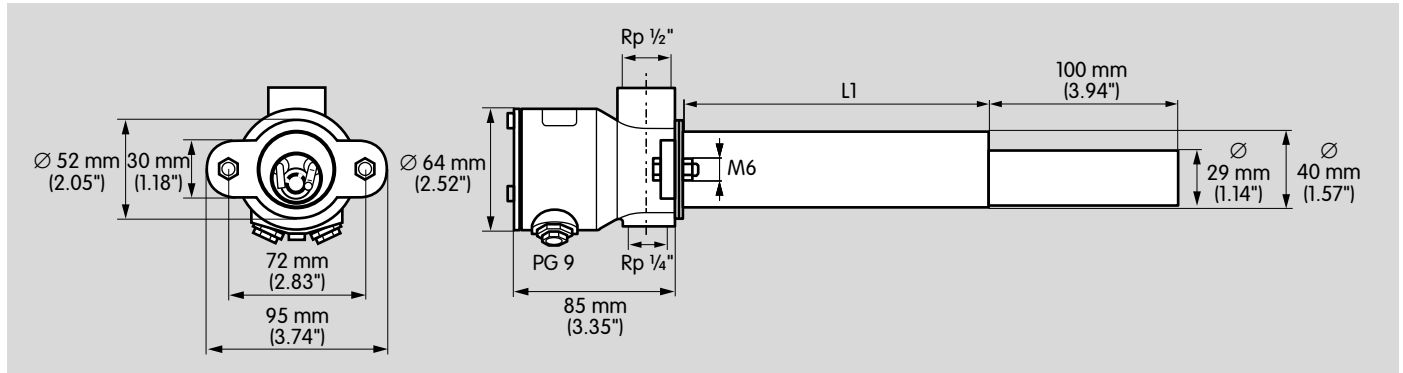

Type	Dimensions L1	
	[mm]	[inch]
ZKIH 150/100R	150	5.91
ZKIH 200/100R	200	7.87
ZKIH 300/100R	300	11.8
ZKIH 400/100R	400	15.7
ZKIH 500/100R	500	19.7
ZKIH 600/100R	600	23.6
ZKIH 700/100R	700	27.6
ZKIH 800/100R	800	31.5
ZKIH 900/100R	900	35.4

7.1.2 ZKIHB

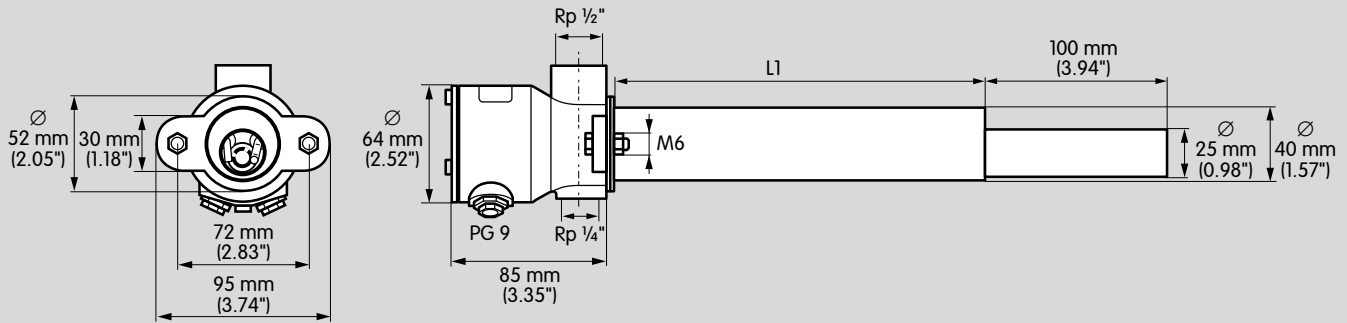

Type	Dimensions L1	
	[mm]	[inch]
ZKIHB 180/100R	180	7.09
ZKIHB 230/100R	230	9.06
ZKIHB 330/100R	330	13.0
ZKIHB 430/100R	430	16.9
ZKIHB 530/100R	530	20.9
ZKIHB 630/100R	630	24.8
ZKIHB 730/100R	730	28.7
ZKIHB 830/100R	830	32.7
ZKIHB 930/100R	930	36.6

7.2 Converting units

see www.adlatus.org/?sprache=1

8 Maintenance cycles

Twice per year, but if the media are highly contaminated, this interval should be reduced.

Feedback

Finally, we are offering you the opportunity to assess this “Technical Information (TI)” and to give us your opinion, so that we can improve our documents further and suit them to your needs.

Clarity

- Found information quickly
- Searched for a long time
- Didn't find information
- What is missing?
- No answer

Comprehension

- Coherent
- Too complicated
- No answer

Scope

- Too little
- Sufficient
- Too wide
- No answer



Use

- To get to know the product
- To choose a product
- Planning
- To look for information

Navigation

- I can find my way around
- I got “lost”
- No answer

My scope of functions

- Technical department
- Sales
- No answer

Remarks

Contact

Elster GmbH
Postfach 2809 · 49018 Osnabrück
Strothweg 1 · 49504 Lotte (Büren)
Germany

Tel +49 541 1214-0
Fax +49 541 1214-370
info@kromschroeder.com
www.kromschroeder.com

The current addresses of our international agents are available on the Internet:
www.kromschroeder.de/Weltweit.20.0.html?&L=1

We reserve the right to make technical modifications in the interests of progress.
Copyright © 2016 Elster GmbH
All rights reserved.

