

Burners



Self-recuperative burners
high speed radiant tube

REKO-SIK-NxT-RT (E3901RN rev. 01 -11/11/2019)

GENERAL WARNINGS



- Each manual, including this one, is an integral part of the ESA PYRONICS catalogue.
- Each manual may contain errors or give rise to doubts about interpretation. ESA PYRONICS invites you to report any error or doubt in interpretation but will not be able to consider such occurrences as a sufficient cause of any disputes.
- Nothing in this manual and every part of it (logos, texts, photos, tables, graphs, etc.) may be reproduced or modified in whole or in part without the written consent of ESA PYRONICS.
- All installation, maintenance, ignition and calibration operations must be carried out by qualified personnel in compliance with all the points indicated in this manual. The indications reported in this document do not exonerate the Customer from the observance of the general and specific legal provisions.
- All personnel responsible for the control and operation of the device must be informed of the contents of this manual and must follow their instructions scrupulously.
- The performance of the products indicated in each manual is the result of tests conducted at the ESA-PYRONICS Research Center. The tests were performed using ESA-PYRONICS equipment. These services cannot therefore be guaranteed using other equipment.
- ESA-PYRONICS reserves the right to modify the technical characteristics of the products by updating the relative manual at any time and without notice. By consulting the website www.esapyronics.com it is possible to download the manuals updated to the latest revision in Italian.

LOGISTICS AND DISPOSAL

Transport: Protect the equipment from shocks, bumps, vibrations or temperature changes. When receiving the product, check labelling and promptly report any transport damage.

Storage: Store the product in a place protected from atmospheric agents.

Packaging: The packaging material must be disposed of according to local regulations.



Disposal: To be disposed of according to local laws.

CERTIFICATIONS



- ESA PYRONICS operates with a Quality System certified by DNV GL in compliance with the **UNI EN ISO 9001** standard.
- ESA PYRONICS operates following the Code of Ethics and Behavior pursuant to Legislative Decree **D.Lgs. 231/01**.
- All ESA PYRONICS products are designed, manufactured and checked according to the applicable requirements described in the **UNI EN 746-2:2010** "Industrial thermal process equipment - Part 2: Safety requirements for combustion and for fuel handling and treatment" harmonized with the Machine Directive **2006/42/EC**.
- According to Annex II nr.1B of the Machine Directive 2006/42/EC, the burner is considered an "almost-machine". The declaration of incorporation is available.
- The products conform to the requests for the Euroasia market **EAC** (Russia, Belarus and Kazakhstan).

CONTACTS / SERVICE



Esa S.p.A.

via Enrico Fermi 40, 24035 Curno (BG) - Italy
tel +39.035.6227411 / fax +39.035.6227499
esa@esacombustion.it

Esa Belgium

Zoning Industriel, 4ème rue, B-6040 Jumet - Belgium
tel +32.71.256970 / fax +32.71.256979
marketing@pyronics.be

Esa India

Plot No. J-17, MIDC, Bhosari, Pune, 411 026 - India
tel.: +91 982 2601452
esaindia@esapyronics.com

www.esapyronics.com

The REKO-SIK-NxT-RT are self-recuperative gas burners for direct heating. These burners use heat from the combustion exhaust fumes to pre-heat the combusive air. According to their size and utility conditions, this type of burner guarantees a substantial decrease in consumption compared to traditional burners.

APPLICATIONS

- Furnaces with fibre covering.
- Ceramic or treatment furnaces.
- Tunnel or chariot furnaces.
- Indirect heating applications and furnaces.

The REKO-SIK-NxT-RT technology is applied to different radiant tube configurations (in steel or silicon carbide).

1 - Straight tube with silicon carbide internal flame tube lined up in modules. This has been done to allow for longer lasting internal modules and excellent temperature distribution on the radiant tube. Moreover, in case of rupture, it is possible to replace only the damaged module, thus saving considerably in terms of costs.

2 - P or double P tubes, where the needs of ample irradiant surfaces integrate with a burner that has an incorporated recuperator.



CARATTERISTICS

GENERAL:

- Capacity: from 15 to 150 kW
- Functions with various types of gas: CH₄/LPG/Propane/etc.
- Maximum furnace temperature: 1150 °C
- Burner air inlet pressure: 50 mbar
- Burner gas inlet pressure: 50 mbar
- Inlet air temperature: environment
- Preheated air temperature: up to 750°C
- Low NO_x e CO emissions
- Easily replaceable electrode.
- Separate air and gas inlets, nozzle mixers no flashbacks.

MATERIAL COMPOSITION:

- Exhaust air-inlet body: Cast iron G25
- Gas collector pipe: Cast iron G25
- Exchange tube: Si SiC
- Combustion head: AISI310S/INCOLOY601
- Furnace wall spacer: on request
- Surface treatment: phosphating
high temperature painting



CAPACITY PARAMETERS

The REKO-SIK-NxT-RT ignition takes place through a high voltage discharge, which is carried out by a WAND electrode. The flame is detected via a uv-scanner (not

included). The adoption of flame controls is highly recommended in all systems operating at temperatures below 750°C (UNI EN746-2 Norm).

Model	Capacity kW	Flame velocity mm	Recommended radiant tube diameter *
REKO-15-SIK-NxT-RT	15	120	90÷114
REKO-30-SIK-NxT-RT	30	120	114÷150
REKO-60-SIK-NxT-RT	60	120	130÷200
REKO-100-SIK-NxT-RT	100	120	180÷220
REKO-150-SIK-NxT-RT	150	110	200÷300

* possibility to use different diameters after a technical evaluation.

IGNITION AND DETECTION

The REKO-SIK-NxT-RT burners are ignited mainly by high voltage discharge supplied by an EN or WAND series electrode.

Flame detection takes place through a special EN or

WAND series electrode and the UV-2 series ultraviolet photocell can always be used on request. The flame controls are strongly recommended in all plants operating at temperatures below 750°C.

Model	Ignition with electrode	
	Ignition	Detection (*)
REKO-15-SIK-NxT-RT	ESA WAND	ESA WAND/UV2
REKO-30-SIK-NxT-RT	ESA WAND	ESA WAND/UV2
REKO-60-SIK-NxT-RT	ESA WAND	ESA WAND/UV2
REKO-100-SIK-NxT-RT	ESA WAND	ESA WAND/UV2
REKO-150-SIK-NxT-RT	ESA WAND	ESA WAND/UV2

(*) UV2 optional

DESCRIPTION

I bruciatori REKO-SIK-NxT-RT sfruttano la temperatura dei fumi in uscita per preriscaldare l'aria comburente,

ottenendo un ottimo risparmio energetico e riducendo le emissioni inquinanti in atmosfera.

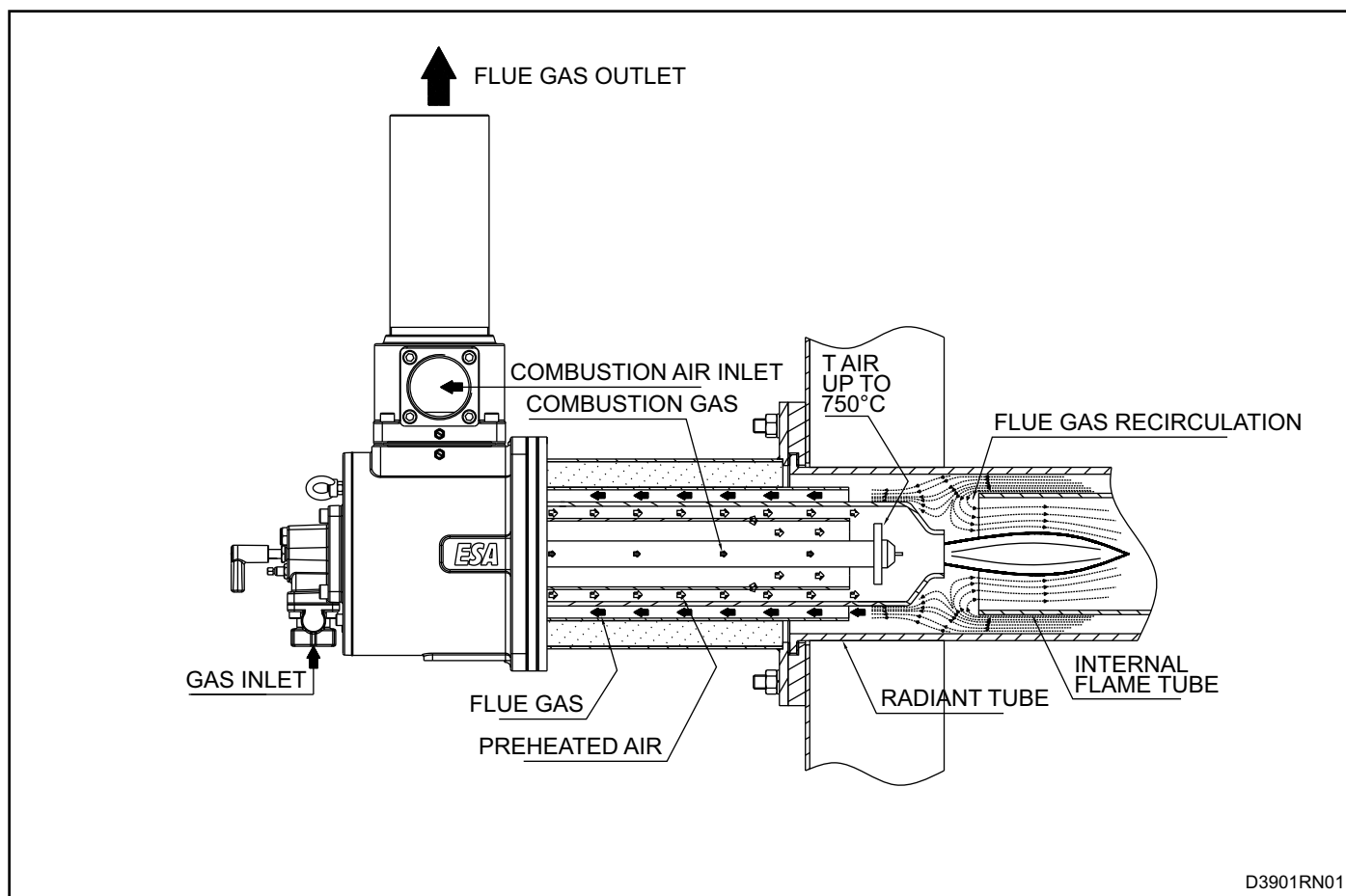

The choice of materials has been made to perfect the duration and performance of the burner. The insulated collector with compressed fiber assures high resistance against heat and oxidation. The heat exchange element is made of silicon carbide and its special conformation allows better heat transfer from the combustion products to the combustive air. This allows the burner to be used at maximum chamber temperatures of up to 1150°C in indirect heating conditions. Multistage combustion technology, together with the recycling of combustive gases, gua-

rantees low NOx and CO emissions, despite the preheating air temperature value of up to 750°C. The REKO-SIK-NxT-RT are compact burners with reduced weight and size. They have separate gas and air inlets, nozzle mixers (no flashbacks) and include: micrometric gas adjuster, spark electrode, peepsight, calibrated inserts, gas calibrated orifice flow meter and furnace wall spacer. The suggested functioning is with OFF/MIN/MAX the setting is simplified by special pressure inlets on the air and gas side.

BURNER PERFORMANCES

The flame capacity, length and velocity concern natural gas burners (8600 Kcal/Nm³), placed in a combustion chamber with zero pressure and at sea level, which can function with 10% of excess air.

- ON/OFF functioning
- Chamber temperature 850°C
- NO_x < 350 mg/Nm³ [O₂ = 3% ref.]

MAXIMUM CAPACITY

Radiant tube application			Burner model				
			REKO-15 SIK-NxT-RT	REKO-30 SIK-NxT-RT	REKO-60 SIK-NxT-RT	REKO-100 SIK-NxT-RT	REKO-150 SIK-NxT-RT
Maximum power	SiC recuperator length	[mm]	540	605	680	680	720
	Burner capacity (2% O₂)	[kW]	15	30	60	100	150
	Burner air flow	[Nm ³ /h]	16.5	33	66	110	165
	Gas flow	[Nm ³ /h]	1.5	3	6	10	15
	Burner air inlet pressure	[mbar]	50	50	50	50	50
	Δp flange gas measurement	[mbar]	10	10	10	10	10

MINIMUM SETTING (BURNER OFF)

Radiant tube application			Burner model				
			REKO-15 SIK-NxT-RT	REKO-30 SIK-NxT-RT	REKO-60 SIK-NxT-RT	REKO-100 SIK-NxT-RT	REKO-150 SIK-NxT-RT
Minimum power	Burner capacity (2% O₂)	[kW]	3	6	12	20	30
	Burner air flow	[Nm ³ /h]	3.3	6.6	13.2	22	33
	Gas flow	[Nm ³ /h]	0.3	0.6	1.2	2	3
	Burner air inlet pressure	[mbar]	2	2	2	2	2
	Δp flange gas measurement	[mbar]	0.4	0.4	0.4	0.4	0.4

EFFICIENCY TABLES (TEST DATA)

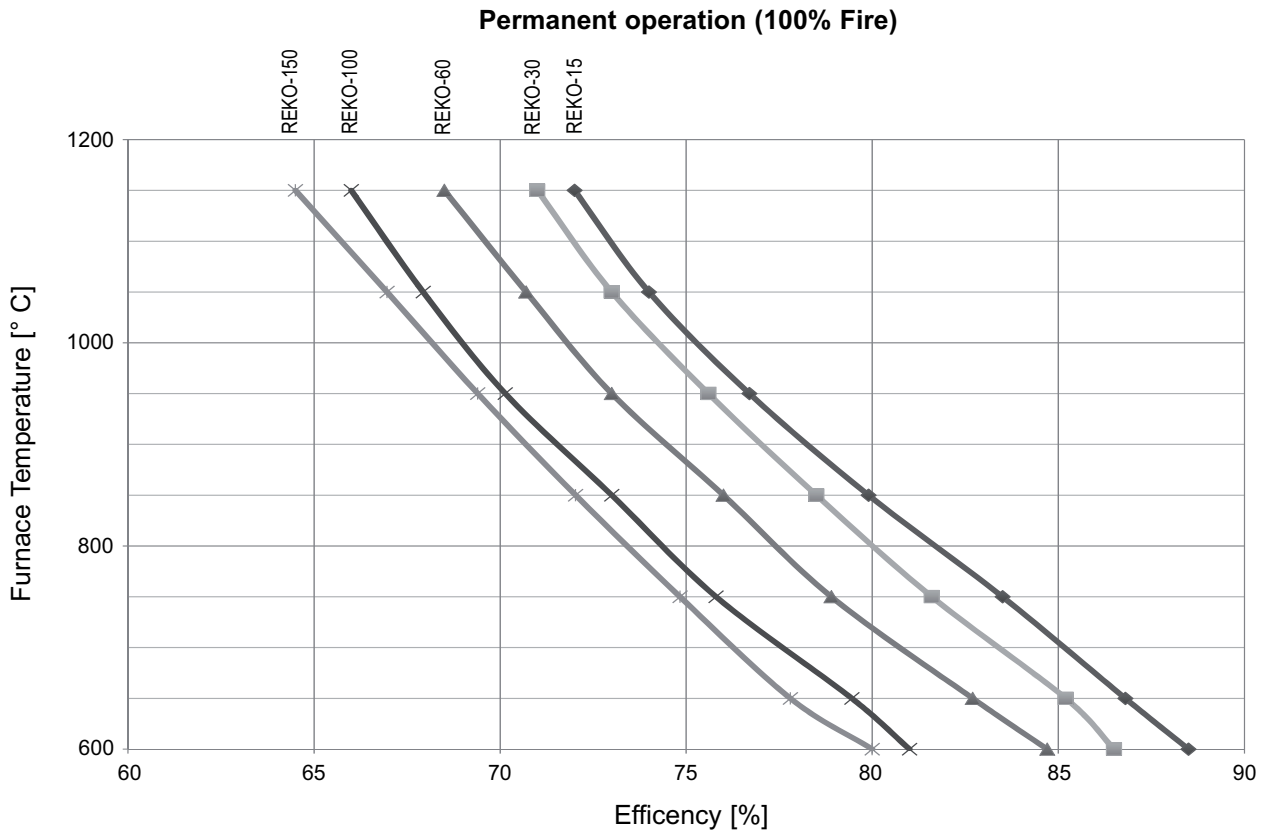

G3901R01

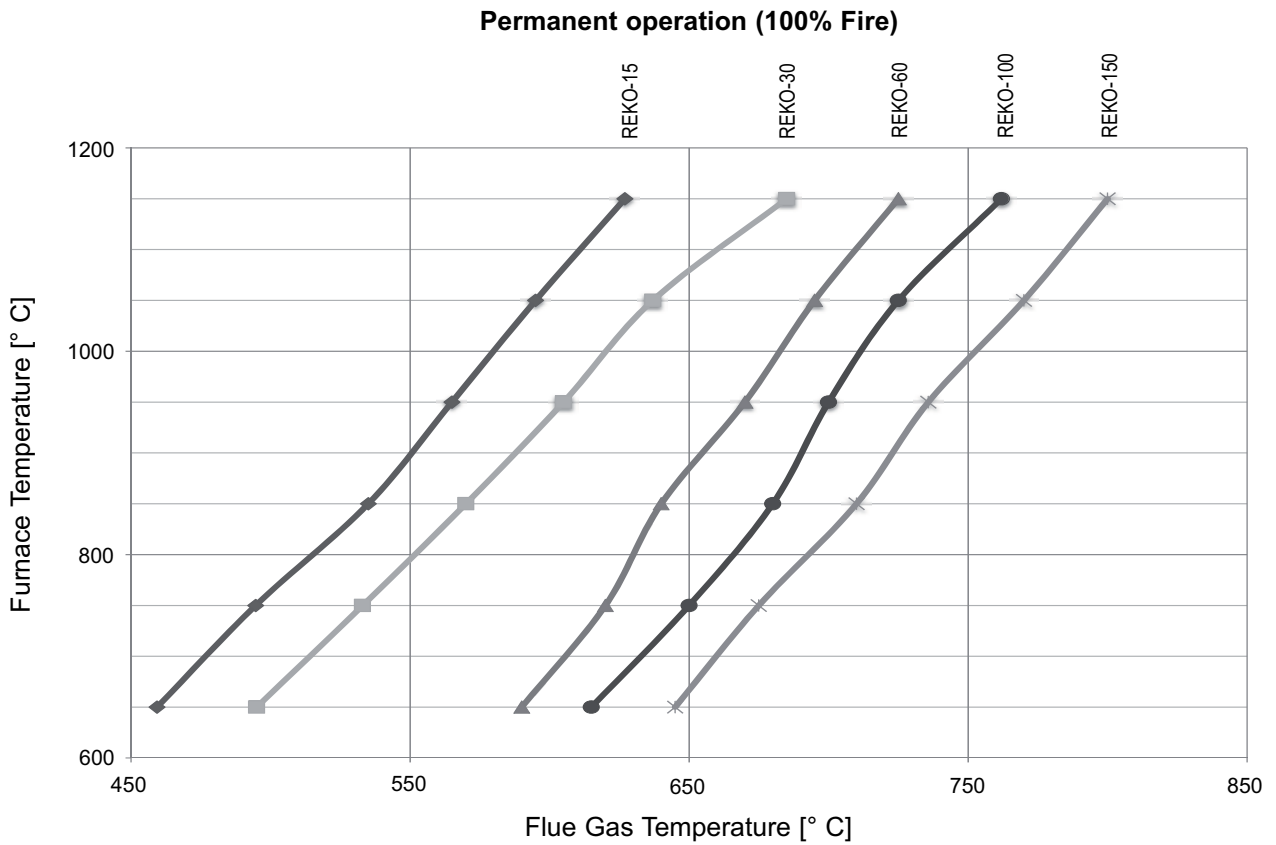

G3901R02

FLOW SCHEME

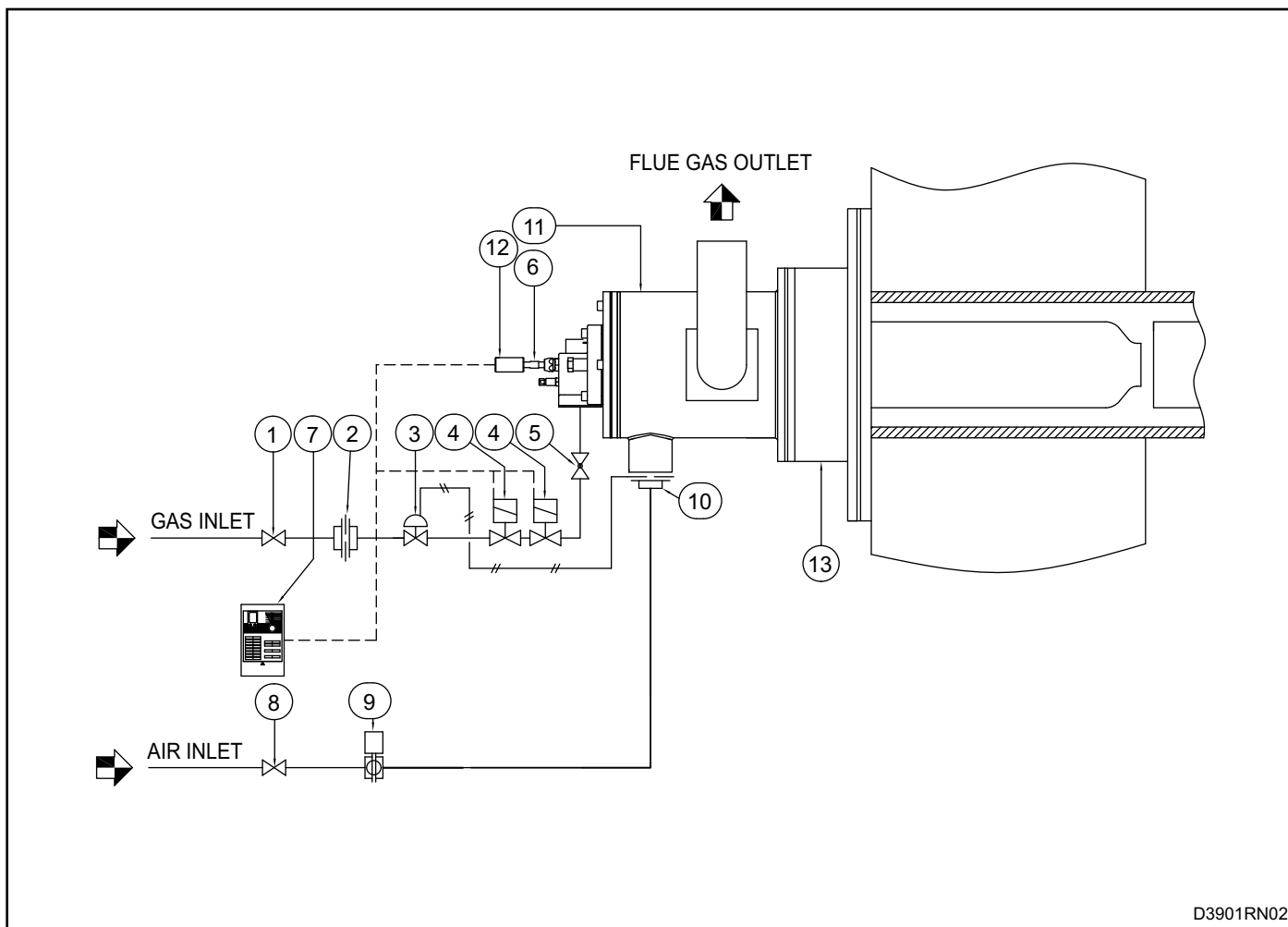

D3901RN02

Pos.	Description	Included	Not Included
1	Gas ball valve		X
2	Gas calibrated flange	X	
3	Pressure regulator		X
4	Safety solenoid valve		X
5	Throttle valve	X	
6	Ignition electrode	X	
7	Flame control		X
8	Air ball valve		X
9	Motorized regulation valve		X
10	Combustion air orifice flow meter	X	
11	Self-recuperative burner	X	
12	Detection electrode	X	
13	Furnace wall adapting spacer		X

TECHNICAL NOTES FOR THE CHOICE OF RADIANT TUBES

The radiant tubes made up of lined up modules for the REKO-SIK-NxT-RT series of self-recuperative burners are used in indirect heating applications where the fumes of the burner cannot come into contact with the furnace atmosphere. They are composed of an external tube and an internal concentric tube in SiC made up of modules with predefined lengths. The burner is assembled concentrically to the system. The special internal SiC tube design, together with the high velocity of the combusive products exiting the burner, guarantees:

- More uniform surface temperature along the length of the tube.
- Reduced NOx e CO emissions as a result of the strong recirculation of the combusive products.
- Thermal exchange in high countercurrent between products and air combustion.
- Greater efficiency, reduced consumption (up to 35%) compared to traditional burners.
- External radiant tube thermally less stressed, thus advantageous for its average lifespan.
- Easier replacement of internal SiC modules for rapid and less expensive maintenance.

CHARACTERISTICS

The choice of straight radiant tubes can be made between different sizes with different diameters and thickness.

- External diameters from Ø 80 to Ø 210 (other sizes available on request).
- Lengths according to Client's request.
- Inside in ceramic and outside metallic for working temp. up to 1000°C.
- Outside and inside both ceramic for temp. up to 1250°C (allow dissipation for about double the unit area compared to metallic tubes of equal dimensions).

RADIANT TUBES/INTERNAL MODULES

ESA PYRONICS suggests two types of assembly schemes:

- Metallic external radiant tube with internal flameguard tube in ceramic modules.
- Ceramic external radiant tube with internal flame guard tube in ceramic modules.

METALLIC DESIGN: length between 1000 and 3000mm

CERAMIC DESIGN: length between 1000 and 2400mm

All types can be used in both horizontal and vertical assemblage. In the metallic design, with tubes that are longer than 1 metre, provide the final part of the radiant tube with a support coupling so that the actual tube is supported by a metallic or ceramic bracket that has a low friction coefficient made in the wall that lies opposite the housing wall (leaving open space to compensate thermal dilation)

INTERNAL CERAMIC TUBE CHARACTERISTICS

The internal ceramic tube is made of standard length AD-SiC modules of 250mm and a final adaptable module (with a length that varies from 150 to 400mm, closed on the end for greater protection of the bottom of the metallic radiant tube). Both modules are provided with two rows of centering elements for an adequate housing inside the radiant tube. The centering pins have been built directly inside the mould, to avoid glueing that can provoke accidental detachment during operation. They are constructively robust and resistant to the thermal and mechanical stress that their application requires.

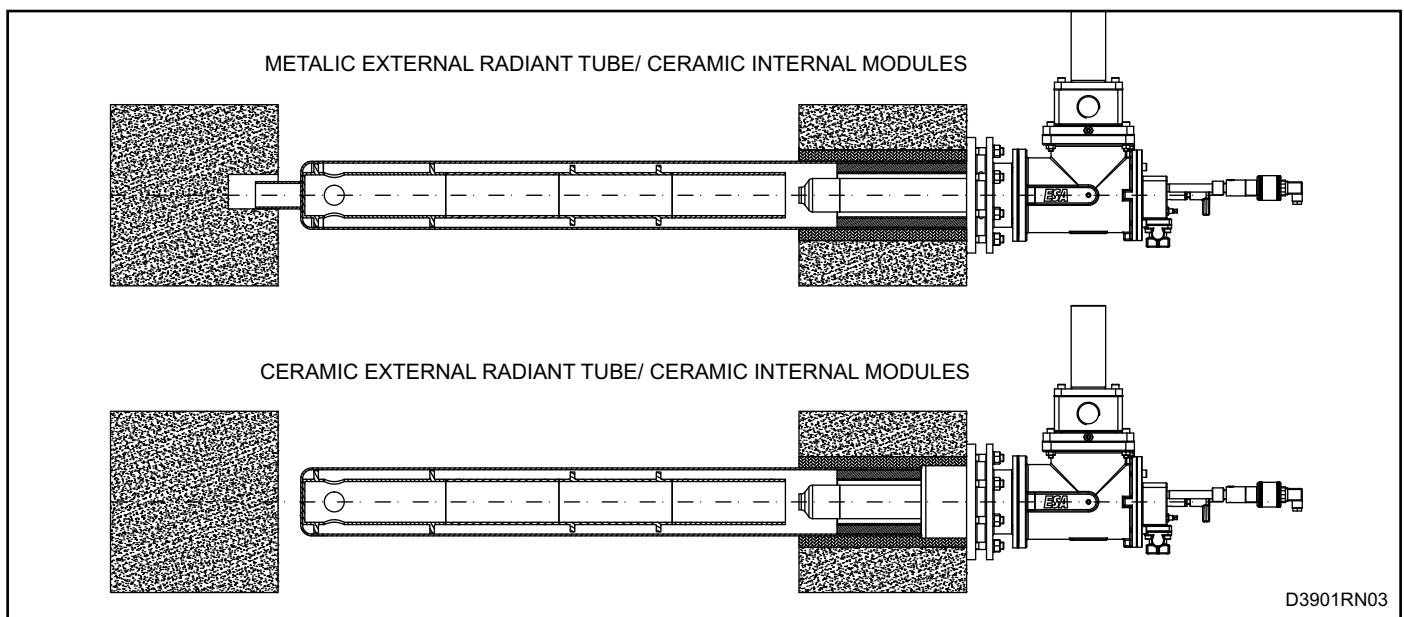

TECHNICAL NOTES FOR THE CHOICE OF RADIANT TUBES



F3901RN03

RADIANT TUBE AND INTERNAL MODULE DIMENSION TABLE

The table contains the standard measurements which are mainly used. Other measurements available on request.

The burner sizes with their appropriate radiant tube dimensions are also present.

Radiant tube dia. (mm)	Suggested models	SiC Moduels dia. (mm)	SiC Module lenght (mm)	SiC Terminal module lenght [min/max] (mm)
80	REKO-15-SIK-NxT-RT	58	250	150/400
90	REKO-15-SIK-NxT-RT	64		
114	REKO-15-SIK-NxT-RT	80		
	REKO-30-SIK-NxT-RT			
130	REKO-30-SIK-NxT-RT	90		
	REKO-60-SIK-NxT-RT			
152	REKO-30-SIK-NxT-RT	106		
	REKO-60-SIK-NxT-RT			
170/180	REKO-60-SIK-NxT-RT	121		
	REKO-100-SIK-NxT-RT			
190	REKO-60-SIK-NxT-RT	131		
	REKO-100-SIK-NxT-RT			
200/210	REKO-100-SIK-NxT-RT	140		
	REKO-150-SIK-NxT-RT			

RADIANT TUBE DISSIPATION

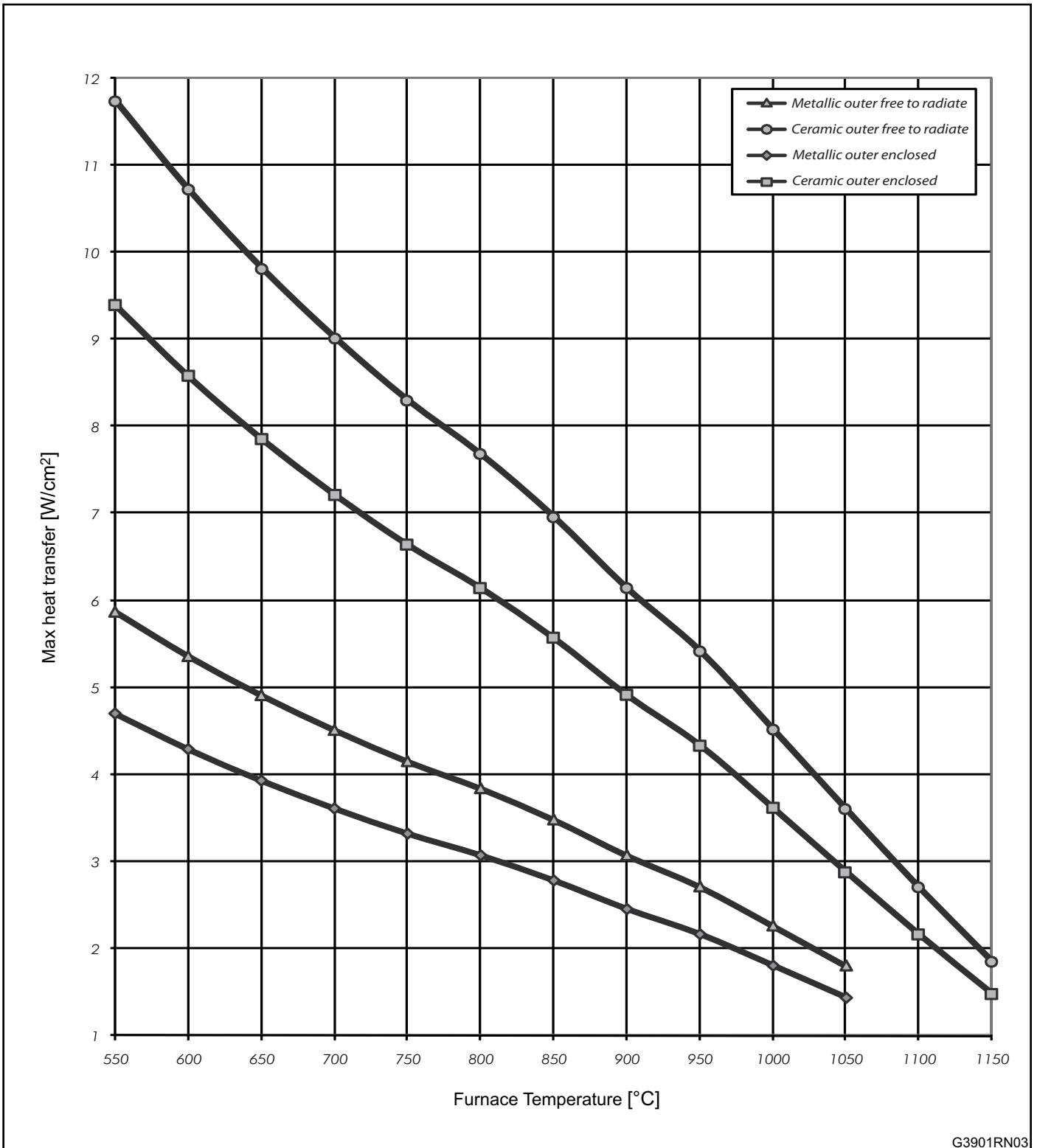

G3901RN03

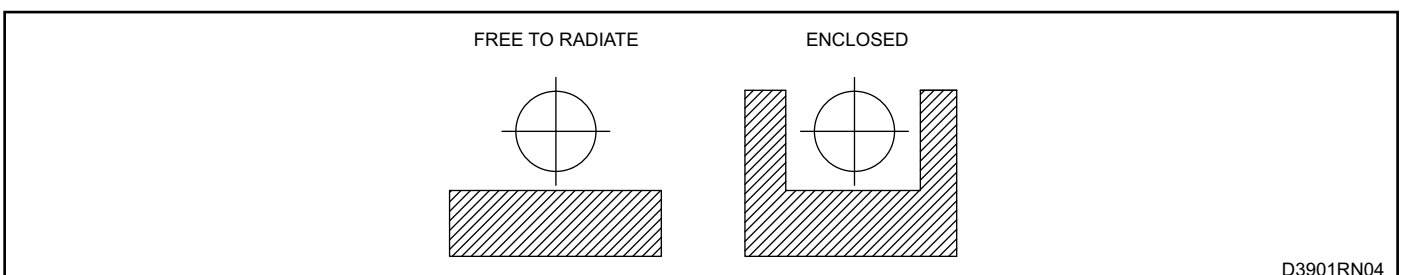

D3901RN04

SIZING CHART FOR REKO-SIK-NxT-RT RADIANT TUBE AND BURNER

Client	
Total width of furnace "A" [mm]	
Wall Thickness "X" [mm]	
Radiant tube "L" = "A" + "X" [mm]	
Furnace temperature [° C]	

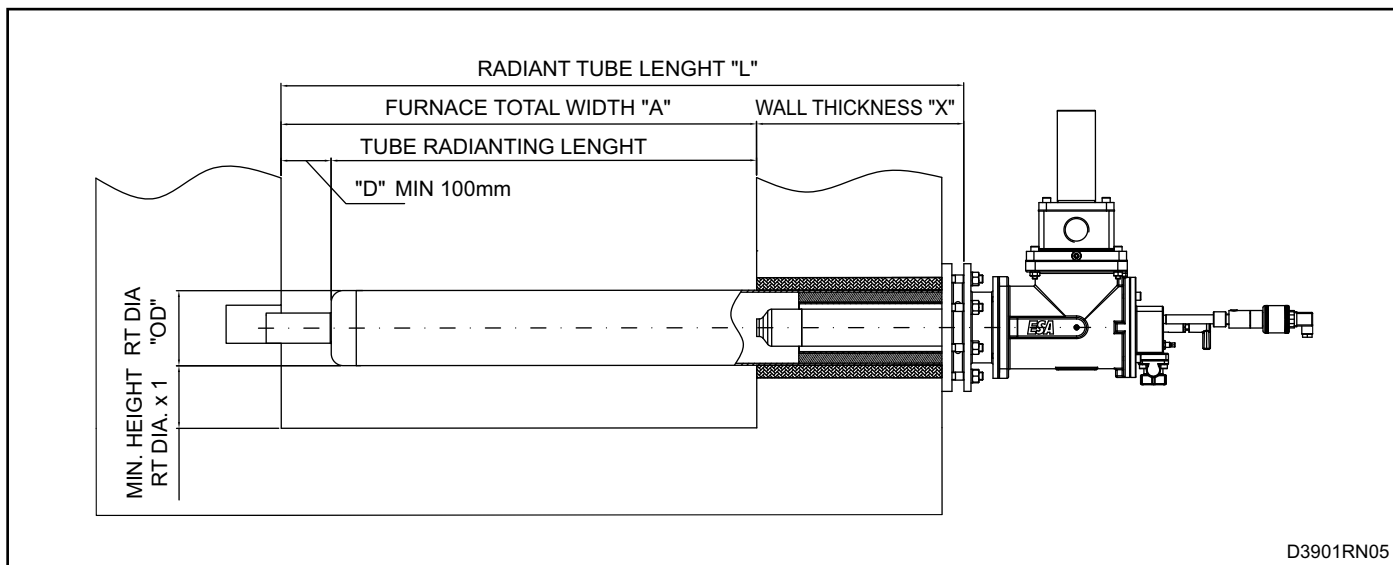

Radiant tube installation (see drawing pag. 10)	<input type="checkbox"/>	Free tube
	<input type="checkbox"/>	Crowned
Radiant tube external material	<input type="checkbox"/>	Metallic
	<input type="checkbox"/>	Ceramic

MAX COEF. THERMAL FLOW see table. pag. 10		W/cm ²
RADIANT TUBE EXTERNAL DIAMETER "OD"		mm

Total surface area "S" = $\frac{"OD" \times 3.14 \times (A-D)}{1.000.000}$ m²

Net tube capacity = "S" x FLOW x 10 Kw

Maximum burner capacity = $\frac{\text{net tube capacity}}{0.7}$ Kw

- Fuel**
- Natural gas
 - Lpg
 - Other

WARNINGS

- The REKO-SIK-NxT-RT burner series is intended for fixed installations. If mobile installations are needed (bell furnaces, etc...) it is necessary to preventively take into consideration the possibility of damage to hoses in silicon carbide, which is determined by the movement of the actual furnace.
- The burner must always be turned on at minimum power, using slow opening regulation valves, facilitating ignition and reducing exit overpressure.
- The passing from minimum power to maximum power must always be done gradually and not instantaneously. To do this, the use of two-phase air modulating regulation valves is suggested.
- For all applications at low temperature (up to 750°C), burner ignition and the control of solenoid gas valves must be accomplished using a certified burner control device.
- To avoid possible damage to the burners, make sure that the blower does not send them hot or foul air (from combustion products, oils, solvents or other). To avoid this from occurring, install the blower or the air suction duct outside the establishment and far from the exhaust pipes.
- Check that the power lines are properly connected after the installation. Before turning on the burner check the correct combustive air and fuel gas settings (pag. 5).
- The burner can only work within the indicated power range. The functioning with less or more power can compromise the correct functioning and life span of the actual burner. In this case the general warrantee conditions will not be applicable anymore and ESA-PYRONICS will not be held responsible for any damage caused to persons or things.
- If there is trouble with other devices during the burner start up phase, use the connector with anti disturbance filter for the high-tension (HT) cable connection of the ignition electrode.
- Avoid burner ignition close to each other so as not to heat the ignition command system devices (solenoid valves and transformers). Prewash time lapse + first safety time lapse + min. of 5 sec. = time lapse between one ignition and another. (however, do not attempt more than 2 ignitions during a 30sec. time lapse).
- Make sure the power supply is TURNED OFF when intervening on the burner and its devices. In case of burner malfunctioning, follow the indications in the 'Maintenance' chapter of the present manual or contact ESA-PYRONICS assistance.
- The installation of protective elements (e.g. perforated metallic grids) is suggested to avoid operators accidentally coming into contact with the burner chimney's high temperature surface.
- Any modification or repair done by third parties can compromise the application safety and automatically cause the general warrantee conditions to expire.

INSTALLATION

For the REKO-SIK-NxT-RT burner series installation, carefully follow the instructions below:

1 - Place burners far from heat sources and products such as: liquids, solvents or corrosive gases.

2 - Make sure that the sizes and interaxes of the feeding and exhaust pipes correspond to the specifications in chapter 'Overall Dimensions' page 21 & 22.

3 - After having installed the radiant tube on the wall (**pos. 01**) one by one insert the internal final module (**pos.02**) and then the internal standard modules (**pos. 03**) making sure that they are all correctly pushed into each other on the bottom of the radiant tube. Be careful not to damage the ceramic elements that make up the modules.

4 - Insert the connecting radiant tube flange and the ceramic fibre gasket (**pos. 04**).

5 - Insulate the furnace wall spacer (where present) with a ceramic fibre mattress, according to the indications and drawings in the ' Overall Dimensions' chapter and assemble it against the furnace wall.

6 - Insert the burner (**pos. 06**) into the spacer, interposing the ceramic fibre gasket (**pos. 08**), making sure you have checked the correct positioning of the air and gas inlets as well that of the exhaust pipe. During this operation be careful not to damage the silicon carbide tubes (**pos. 05**). Fasten screws or fixing bolts (**pos. 09**) and lubricate the threads with MOLIKOTE P74.

7 - Fix the exhaust pipe to the chimney, (**pos. 07**). The use of natural draught open hoods is recommended to avoid the exhaust fumes from remaining under pressure, causing stress conditions or burner malfunctioning.

8 - Connect the combustive air and fuel gas inlet pipes, interposing, if possible, AISI dilation joints.

9 - In the cooling inlet, connect an 8mm Ø tube with relative fitting to the detection scanner (**pos. 12**). This tube must conduct a fixed air flow for sensor cooling.

10 - Connect electrical wiring to ignition electrodes and to the detection scanner, being careful to make the conductors pass as far away as possible from heat sources.

11 - Make sure that the burner body and all its connected metallic elements are correctly connected to the plant's earthing system with appropriate conductors.

12 - The connection cable of the ignition electrode transformer must be specifically for high tension and not screened. It must not be more than about 1 meter long; otherwise the ignition transformer must be placed near the burner. The HT cable must be placed far from power supply cables and not in metallic conductors. Ideally it should be left in open air. For more details, consult the technical data sheet regarding the ignition transformers E5004.

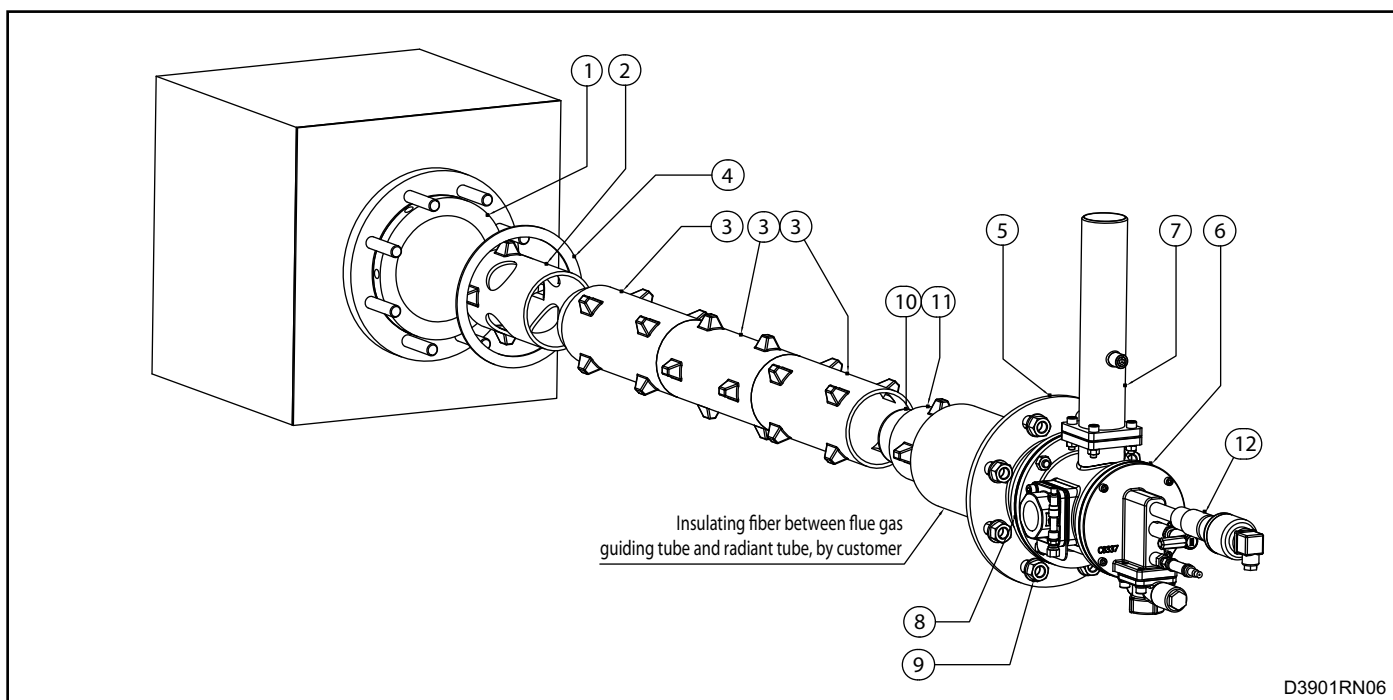

START UP AND SETTING

The procedures indicated in the following chapter must be carried out by expert technicians. The non-observance of the instructions given can provoke dangerous conditions.

1 - Check that the combustion air pressure exiting the blower and the combustive fuel pressure are both within the allowed range.

2 - Adjust the working pressure and the safety device pressure of the combustion plant, whether there is one per burner or one for the whole plant i.e. gas pressure reduction gear, block valve, relief valve, pressure switches etc. Simulate the intervention of all the safety devices including the intervention of the safety over temperature, checking that the fuel safety block devices act properly.

3 - Place the air regulation valve in the maximum opening position and adjust the pressure referring to the values indicated in the 'Burner Performances' chapter for the maximum power supply - pag.05 according to the maximum power.

4 - Place the air regulation valve in the minimum opening position and adjust its opening to obtain (in burner inlet) the relative minimum power pressure.

5 - Activate the burner control device and attempt the ignition until the burner switches on. While attempting to ignite the burner, act on the gas adjustment valve and, starting from the totally closed position, open it gradually until the burner ignites.

6 - Fully open the air regulation valve and adjust, via the gas adjustment valve, the maximum fuel capacity, checking the differential pressure created on the calibrated gas flange. The setting at minimum value is obtained with the air valve at its minimum opening, acting on the regulation screw which is placed inside the pneumatic adjuster.

7 - Double check that, at minimum and maximum power, the burner inlet pressures correspond to the values in the 'Burner Performances' chapter. These values may differ depending on whether the burner is on or off.

8 - With the furnace set temperature, analyse the combustion products on the burner chimney, with a portable analyser, and if necessary, adjust the air and gas pressures and flow (O_2 refers to a max capacity of 2÷4%, minimum capacity of 3÷6%).

9 - Repeatedly attempt ignition at minimum burner power, with maximum amplitude, to check the ignition reliability and flame stability during the adjustment.

NATURAL GAS CAPACITY CHART - REKO-SIK-NxT-RT

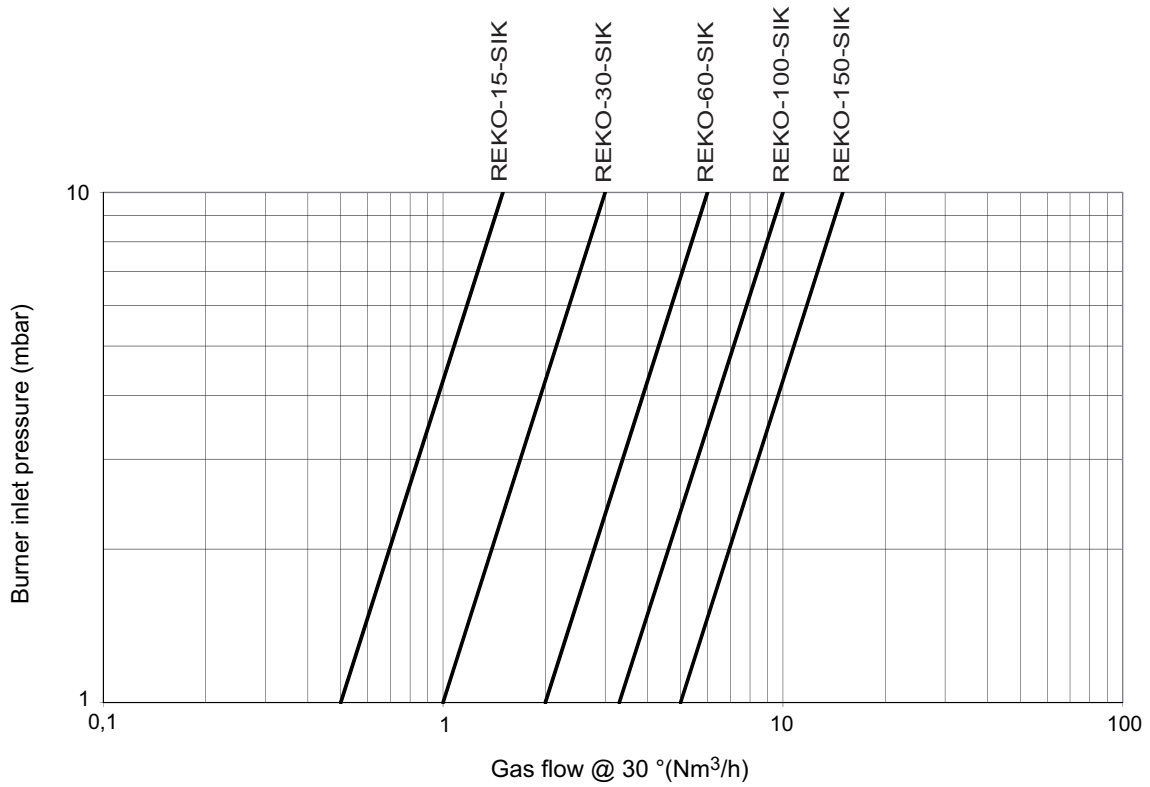

G3901RN04

AIR CAPACITY CHART - REKO-SIK-NxT-RT

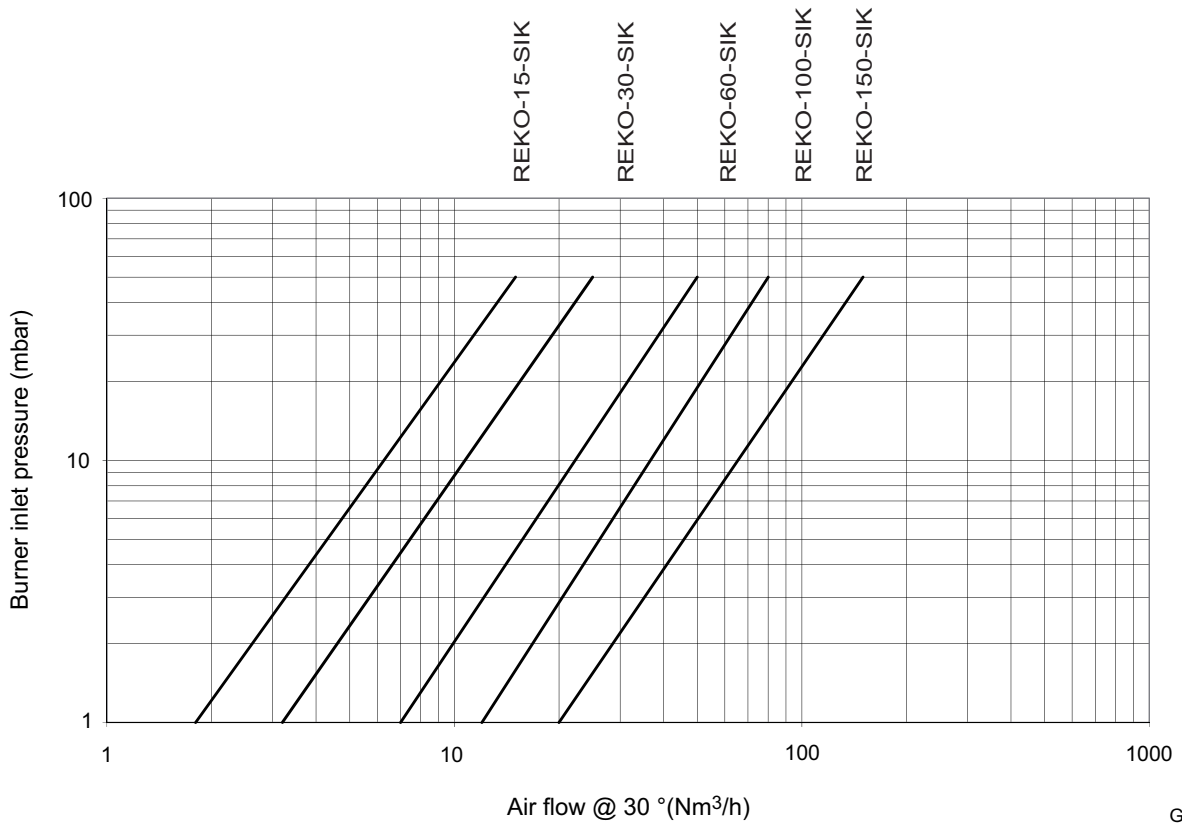

G3901RN05

GENERAL MAINTENANCE PLAN

Operation	Advised time	Notes
High tension electrode connection	annual	check integrity of outer plastic and oxidization of internal electrode terminal.
Ignition electrode	annual	replace if the Kantal terminal is worn.
Fume guiding tube spacer integrity	two yearly	at every maintenance check with furnace turned off, from the inside, make sure there are no cracks in the refractory material.
SiC heat exchanger integrity	two yearly	at every maintenance check with furnace turned off, from the inside, make sure there are no cracks in the refractory material.
Integrity of internal SiC modules	two yearly	check that there are no macroscopic cracks or damage on the surface.
SiC radiant tube integrity (metallic)	annual	rotate the tubes by means of the appropriate holes.
Cleaning of uv-scanner watch glass	every semester	reduce to quarterly check in dusty environments.
Uv-scanner replacement	10.000 h. of functioning	in any case every two years.
Chimney (**)	annual	to be done only when the furnace is off and cold.
Replacement of gas side gaskets (*)	annual	see note.
Burner settings	annual	repeat the steps in the 'IGNITION AND SETTING' section on page 11.
Fume analysis	annual	with furnace on.

NOTES:

(*) it is suggested that the gaskets on the gas side are replaced after every disassembly of the gas feeding line.

(**) use high temperature gaskets

ORDINARY MAINTENANCE

For correct dismantling and better maintenance of the REKO-SIK-NxT-RT burners, meticulously follow the instructions below with the plant turned off.

CLEANING OF UV-SCANNER WATCH GLASS

1 - Check that the burner control device is not connected.

2 - Disconnect power supply to the uv-scanner (**pos. 01**) and the cooling line (where present **pos. 07**).

3 - Unscrew the aluminium pipe fitting (**pos. 06**) at the base of the gas collector, removing the uv-scanner with its spacer.

4 - Unscrew the aluminium fitting from the insulation teflon connector (**pos. 03**) and remove the quartz watch glass (**pos. 05**).

5 - Clean the quartz watch glass with a damp cloth and proceed to reassemble everything making sure that both the glass as well as the gaskets are put back in the correct positions (**pos. 04**) between the aluminium teflon spacer, before tightening.

6 - Restore the cooling hoses and power connection.

7 - Check the correct flame detection of the uv-scanner.

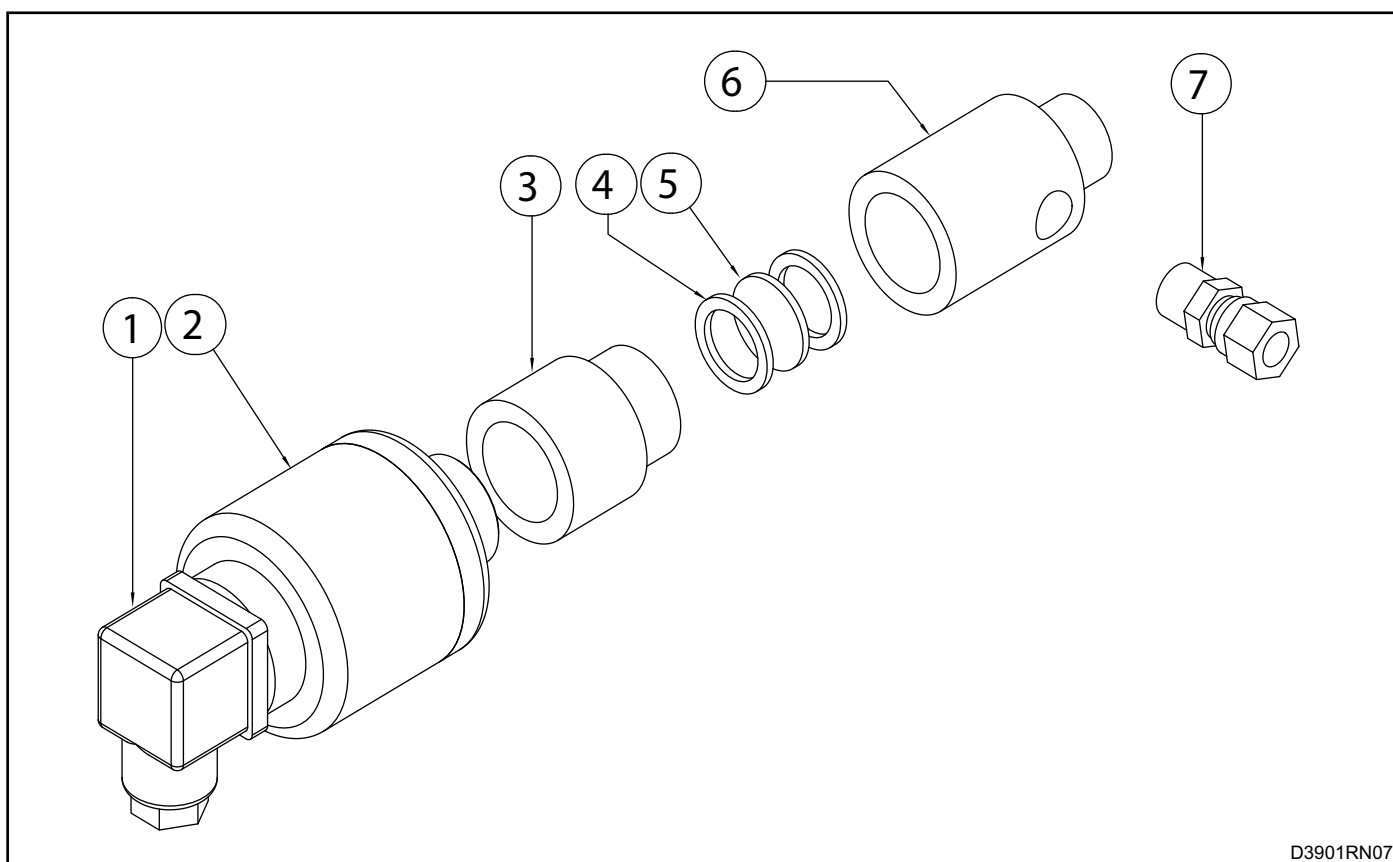

D3901RN07

ORDINARY MAINTENANCE

For correct dismantling and better maintenance of the REKO-SIK-NxT-RT burners, meticulously follow the instructions below with the plant turned off.

CLEANING OF UV-SCANNER WATCH GLASS

- 1 - Check that the burner control device is not connected.
- 2 - Disconnect power supply to the uv-scanner (**pos. 01**) and the cooling line (where present **pos. 07**).
- 3 - Unscrew the aluminium pipe fitting (**pos. 06**) at the base of the gas collector, removing the uv-scanner with its spacer.

4 - Unscrew the aluminium fitting from the insulation teflon connector (**pos. 03**) and remove the quartz watch glass (**pos. 05**).

5 - Clean the quartz watch glass with a damp cloth and proceed to reassemble everything making sure that both the glass as well as the gaskets are put back in the correct positions (**pos. 04**) between the aluminium teflon spacer, before tightening.

6 - Restore the cooling hoses and power connection.

7 - Check the correct flame detection of the uv-scanner.

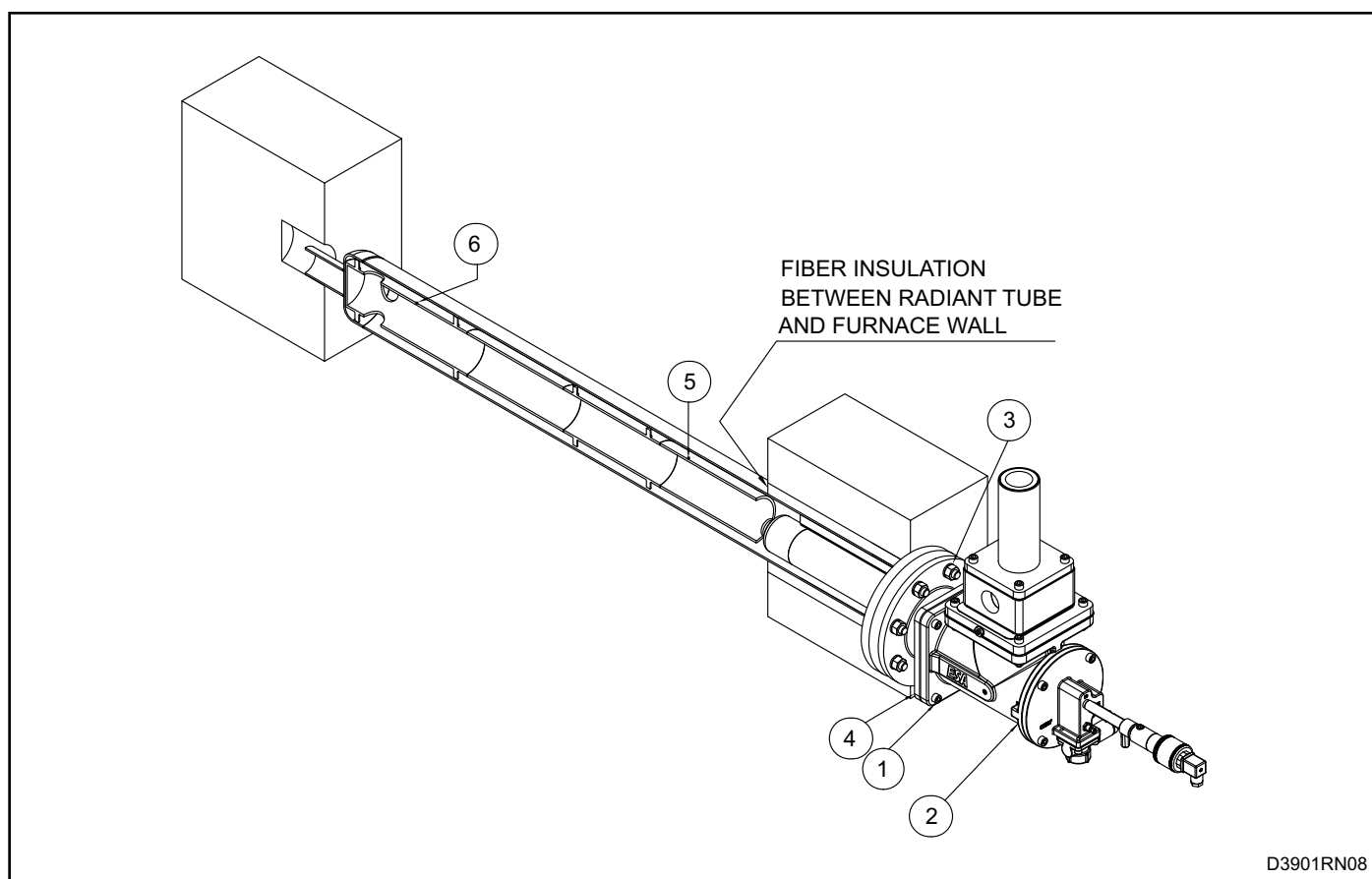

Before assembling, make sure you have new insulation gaskets for the radiant tube, adjusting spacer and burner.

The assemblage procedure is exactly the same as the previous procedure and is carried out by repeating the dismantling steps backwards.

WARNING: pay special attention to the insertion of the internal SiC modules.

1- First insert the closed and perforated end module (**pos.6** see drawing pag.9) and push it to the bottom of the radiant tube, after having placed the tube inside the furnace.

2 - One by one insert the 250mm long standard elements (**pos.5**).

3 - With a non-metallic tool make sure that the all the elements have been pushed in correctly to eachother.

EXTRAORDINARY MAINTENANCE

For correct dismantling and better maintenance of the REKO-SIK-NxT-RT burner, meticulously follow the instructions below with the plant turned off.

BURNER SHUTDOWN

In shutdown conditions of the burner refer to the burner control device indications and to the relative manual to identify the cause. The main cases are indicated here below:

■ **Illegal flame detection:** the shutdown is due to an illegal flame detection during the phases prior to ignition or after the turning off. The causes are within the detection system (broken or faulty sensor or presence of humidity), or in the gas draw from the electric safety valve, which allows the burner to remain turned on.

■ **Failed ignition:** shutdown is caused by the fact that no flame has been created during the starting process. The causes can be found in the start up system (spark absence, faulty electrodes or incorrect position), in the bad setting of the fuel and combustion flow or in the detection system (faulty sensor or interrupted cables). More precisely, in the first two cases the flame is not ignited, while in the last case the flame is created but the burner control device is unable to detect it.

■ **Flame signal loss:** shutdown due to the loss of flame signal during the normal functioning of the burner. The causes can be found in the combustion air flow adjustment (rapid flow variations, adjustment out of allowed range). They can also be found in the detection system (faulty, dirty or badly positioned sensors).

UV-SCANNER REPLACEMENT

- 1 - Check that the burner control device is not connected.
- 2 - Disconnect the electrical flow to the uv-scanner (**pos. 01**) and to the cooling line (where present).
- 3 - Unscrew the aluminium pipe fitting at the base of the gas collector (**pos. 02**), removing the uv-scanner with its spacer.
- 4 - Screw the new component back on, in the same position, after having checked the correct position of the watch glass insulation between the aluminium and teflon spacers.
- 5 - Restore the cooling pipes and the electrical connection.
- 6 - Check the correct uv-scanner flame detection.

IGNITION ELECTRODE REPLACEMENT

- 1 - Check that the burner control device is not connected.
- 2 - Disconnect the Ht cable, by disconnecting the electrode insulation connector (**pos. 06**).
- 3 - Unscrew the upper connector (**pos. 03**) and then extract the retaining spring (**pos. 04**) and the electrode (**pos. 05**).
- 4 - Insert the new electrode, checking its beat. Place the retaining spring back inside and completely screw the connector back on again.
- 5 - Reconnect the electrode insulation connector. Replace it if necessary.

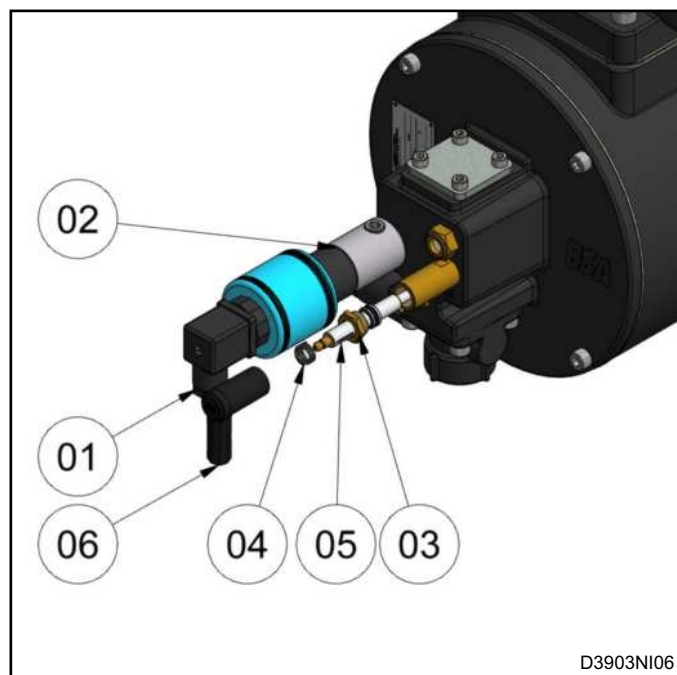

OVERALL DIMENSIONS - REKO-SIK-NxT-RT

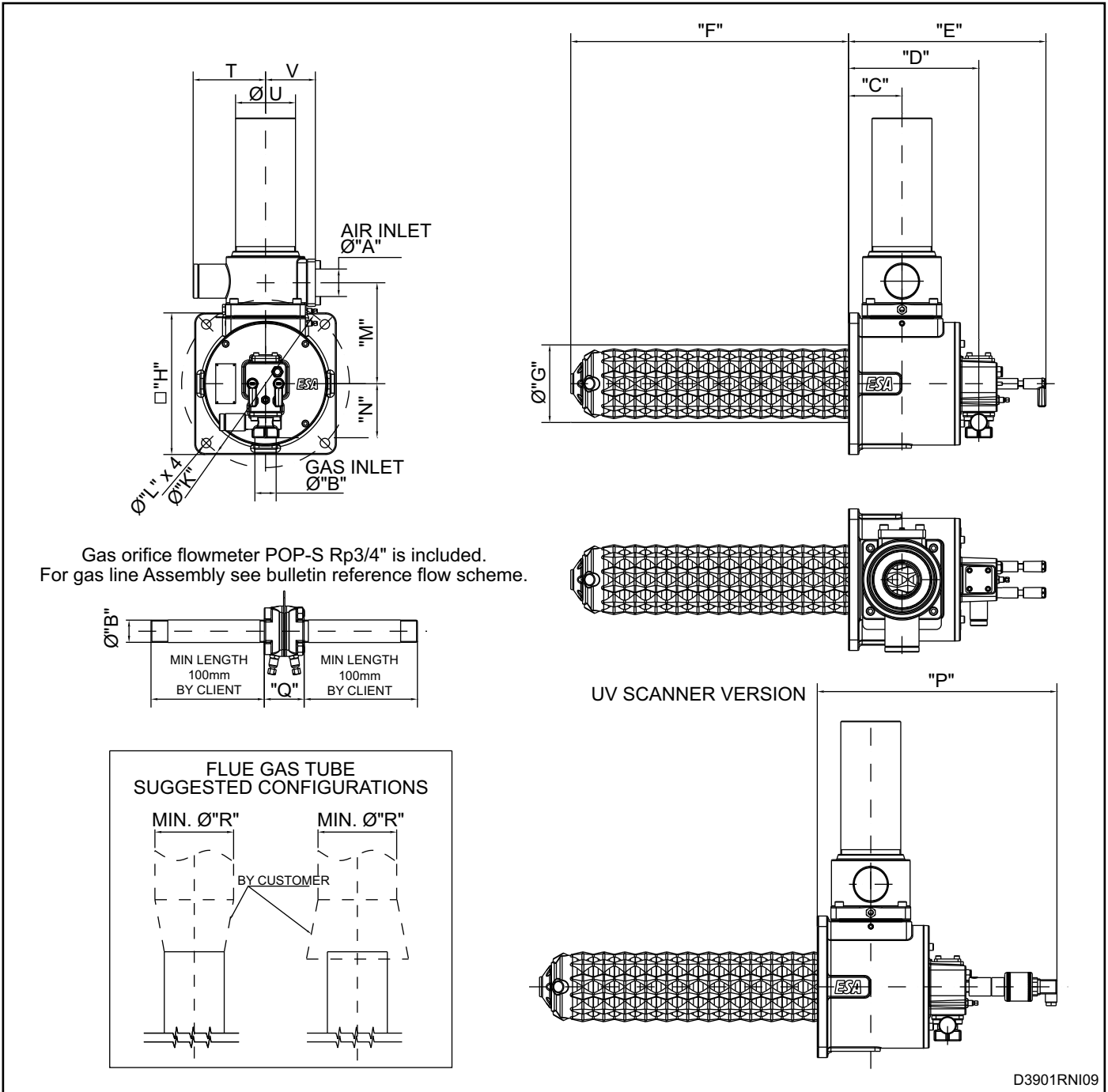

Burner Model	A	B	C mm	D mm	E mm	F mm	G mm	H mm	K mm	L Ø mm	M Ø mm	N mm	P mm	Q mm	R Ø (*)	T mm	U Ø	V mm	Mass Kg (**)
REKO-15-SIK-NxT	G 1"	G 3/8"	154	308	421	380	80	203	235	13.5	195	115	620	48	2.1/2"	129	2.1/2"	95	34.2
REKO-30-SIK-NxT	G 1.1/2"	G 1/2"	154	308	421	400	98	203	235	13.5	195	115	620	48	3"	129	2.1/2"	95	37.5
REKO-60-SIK-NxT	G 2"	G 1/2"	102	248	376	529	118	270	320	18	193	103	457	48	4"	138	4"	111	46.3
REKO-100-SIK-NxT	G 2.1/2"	G 3/4"	102	248	376	529	148	270	320	18	193	103	457	48	4.1/2"	138	4"	95	50.2
REKO-150-SIK-NxT	DN100	G 1"	125	302	433	542	200	380	460	18	265	125	514	48	5.1/2"	173	5"	124	87

Important note: "X" wall thickness is the responsibility of the client.

(*) Indicative diameter (depends on the chimney conformations).

(**) Burner mass including air and gas inlets, exhaust pipe and furnace wall spacer.

ORDERING CODE - COMPLETE BURNER

REKO - 01 - SIK - NxT - RT - 02 - 03 - 04 - E - 06

MODEL		01
REKO-15-SIK	15	
REKO-30-SIK	30	
REKO-60-SIK	60	
... (see. capacity tab.)	

AIR INLET		04
Left		L
Right		R

GAS ADJUSTER		02
With gas adjuster	GA*	
Without gas adjuster	F	

DETECTION		05
Electrode Scanner	E*	UV

FUEL		03
Natural gas	CH4	
LPG	GPL	
Poor gas (¹)	GP	

FLANGING TYPE		06
As ESA drawing	E*	
As Client drawing	C	

The initials marked with an asterisk (*) identify the standards.

Notes:

¹ Particular performance according to gas characteristics.

To check the components that are not supplied with the burner, consult the burner flow scheme on page 7.