

Burners



Free flame burners

EMB (E3004 rev. 09 - 18/01/2018)

GENERAL WARNINGS:



■ All installation, maintenance, ignition and setting must be performed by qualified staff, respecting the norms present at the time and place of the installation.

■ To avoid damage to people and things, it is essential to observe all the points indicated in this handbook. The reported indications do not exonerate the Client/User from observing general or specific laws concerning accidents and environmental safeguarding.

■ The operator must wear proper DPI clothing (shoes, helmets...) and respect the general safety, prevention and precaution norms.

■ To avoid the risks of burns or high voltage electrocution, the operator must avoid all contact with the burner and its control devices during the ignition phase and while it is running at high temperatures.

■ All ordinary and extraordinary maintenance must be performed when the system is stopped.

■ To assure correct and safe use of the combustion plant, it is of extreme importance that the contents of this document be brought to the attention of and be meticulously observed by all personnel in charge of controlling and working the devices.

■ The functioning of a combustion plant can be dangerous and cause injuries to persons or damage to equipment. Every burner must be provided with certified combustion safety and supervision devices.

■ The burner must be installed correctly to prevent any type of accidental/undesired heat transmission from the flame to the operator or the equipment.

■ The performances indicated in this technical document regarding the range of products are a result of experimental tests carried out at ESA-PYRONICS. The tests have been performed using ignition systems, flame detectors and supervisors developed by ESA-PYRONICS. The respect of the above mentioned functioning conditions cannot be guaranteed if equipment, which is not present in the ESA-PYRONICS catalogue, is used.

DISPOSAL:



To dispose of the product, abide by the local legislations regarding it.

GENERAL NOTES:



■ In accordance to the internal policy of constant quality improvement, ESA-PYRONICS reserves the right to modify the technical characteristics of the present document at any time and without warning.

■ It is possible to download technical sheets which have been updated to the latest revision from the www.esapyronics.com website.

■ The EMB products have been designed, manufactured and tested according to the most correct construction practices and following the applicable requirements described in **UNI EN 746-2-2010** "Industrial heating process equipment - Part 2: Safety requirements for combustion and for the handling and processing of fuels". We emphasize that the burners described in this data sheet **are provided as independent units and are excluded from the scope of the Machine Directive 2006/42/EC** not having any mobile items that are not exclusively manual.

■ Certified in conformity with the **UNI EN ISO 9001** Norm by DNV GL.

CERTIFICATIONS:



The products conform to the requests for the Euroasia market (Russia, Belarus and Kazakhstan).

CONTACTS / SERVICE:



Esa S.p.A.
Via Enrico Fermi 40
24035 Curno (BG) - Italy
Tel +39.035.6227411
Fax +39.035.6227499
esa@esacombustion.it

ESA Belgium
Zoning Industriel, 4ème rue
B-6040 Jumet - Belgium
Tel +32.71.256970
Fax +32.71.256979
marketing@pyronics.be

www.esapyronics.com

The EMB are metallic gas burners are used for direct heating. These burners allow excess air, stoichiometric and excess gas regulation. Depending on the size and use, this type of burner can be used for natural gas and LPG combustion (in the standard version) and other types of gaseous combustive agents with heating different properties (special versions on request).

APPLICATIONS

- Ceramic furnaces or fibre cover treatment furnaces.
- Tunnel or chariot furnaces.
- Dryers.
- Textile and dry cleaning machines (Rameause).
- Stretching furnaces.

CHARACTERISTICS

GENERAL:

- | | |
|-----------------------------------|-------------------------------|
| ■ Capacity: | From 20 to 2.500 kW |
| ■ Temperature limit: | 1.000°C |
| ■ Air and gas pressure to burner: | 45mbar |
| ■ Flow ratio: | 8 : 1 |
| ■ Flame speed: | 50-60 m/s |
| ■ Low CO2 content: | ≤10PPM (@ 3% O ₂) |
| ■ Excess air: | up to 400% |

MATERIAL COMPOSITION:

- | | |
|--------------------|-------------------|
| ■ Mixer body: | Cast iron G25 |
| ■ Gas collector: | Cast iron G25 |
| ■ Flameproof tube: | AISI304 / AISI310 |
| ■ Combustion head: | AISI310 |
| ■ Fixing flange: | Fe 360 |



BLOCK HOLDER BURNER VERSION (EMB-BH)

The EMB-BH are gas burners used for direct heating. These burners allow excess air, stoichiometric and excess gas regulation. Depending on the size and use, this type of burner can be used for natural gas and LPG combustion (in the standard version) and other types of gaseous combustive agents with heating different properties (special versions on request). The burner is provided with concrete block holder for special high temperature application such as:

- NOx galvanizing lines.
- Ceramic furnaces or fibre cover treatment furnaces.
- Tunnel or car bottom furnaces.
- Dryers.
- Stretching furnaces.
- Treatment furnaces.



F3400105

CHARACTERISTICS

GENERAL:

- | | |
|-----------------------------------|------------|
| ■ Temperature limit: | 1.300°C |
| ■ Air and gas pressure to burner: | 45mbar |
| ■ Flow ratio: | 8 : 1 |
| ■ Flame speed: | 50-60 m/s |
| ■ Excess air: | up to 400% |
| ■ Excess gas: | up to 20% |
| ■ Preheated air up to: | 550°C |

MATERIAL COMPOSITION:

- | | |
|---------------------|-------------------|
| ■ Mixer body: | Cast iron G25 |
| ■ Gas collector: | Cast iron G25 |
| ■ Flameproof tube: | AISI304 / AISI310 |
| ■ Combustion head: | AISI310 |
| ■ Fixing flange: | Fe |
| ■ Refractory block: | T.max 1750°C |



F3004106

PARAMETER CAPACITY AND FLAME LENGTH

The EMB burner ignition takes place through a high tension discharge obtained via an electrode and the detection is performed by another electrode, or by UV scanner (in block holder version).

The adoption of flame control systems is **highly recommended** in all plants operating at temperatures lower than 750°C (UNI EN746/2 Regulation).

Model	Capacity [kW]	Flame length [mm]	Flame tube outlet diameter [mm]	Flame speed [m/s]	Flame ignition and detection
EMB-0	20	150 ÷ 200	37	40	N.1 WAND electrode
EMB-1	30	300 ÷ 400	43	42	N.2 WAND electrodes
EMB-2	80	500 ÷ 700	64	51	N.2 WAND electrodes
EMB-3	150	700 ÷ 1000	94	44	N.2 EN electrodes
EMB-4	300	1000 ÷ 1250	122	52	N.2 EN electrodes
EMB-5	400	1200 ÷ 1500	122	69	N.2 EN electrodes
EMB-6	600	1500 ÷ 2000	160	56	N.2 EN electrodes
EMB-7	900	1800 ÷ 2400	187	67	N.2 EN electrodes
EMB-8	1.500	2200 ÷ 3000	211	88	N.2 EN electrodes
EMB-9	2000	2800 ÷ 3500	250	75	N.2 EN electrodes
EMB-10	2500	3000 ÷ 3800	250	80	N.2 EN electrodes

The flame lengths and velocities are approximate, they refer to burners fed by natural gas that are placed in open air and function in stoichiometric ratio at nominal capacity.

In special applications, mono-electrodes for the ignition and flame detection are used or else an electrode for flame ignition and a UV photocell for the flame detection is used.

DESCRIPTION

The EMB burners are "nozzle mix" type burners. The fuel and combustive agents are mixed at the combustion head to avoid dangerous flame flashbacks. Furthermore, the special shape of the combustion head allows regulation in stoichiometric ratio as well as in air excess or gas excess. The burners can work also with preheated combustion air up to 550°C.

The EMB burners develop the maximum capacity in stoichiometric ratio with 45mbar of air pressure. This implies the use of low prevalence blowers which are also inexpensive; the setting is simplified due the special differential pressure plugs that allow the measurement of air and gas flow.

BURNER PERFORMANCE

The flame capacity, length and speed refer to a natural gas fed burner (8600 Kcal/Nm³) placed in a com-

bustion chamber at zero pressure above sea level, functioning with 10% of excess air.

- Chamber temperature 1000°C
- NO_x < 200 mg/Nm³ [O₂ = 3% ref.]
- Room air temperature

MAXIMUM CAPACITY

Free flame application			Burner model										
			EMB-0	EMB-1	EMB-2	EMB-3	EMB-4	EMB-5	EMB-6	EMB-7	EMB-8	EMB-9	EMB-10
Max capacity	Burner capacity (2% O ₂)	[kW]	20	30	80	150	300	400	600	900	1500	2000	2500
	Combustion air flow	[Nm ³ /h]	22	33	88	165	330	440	660	990	1650	2200	2750
	Gas flow	[Nm ³ /h]	2	3	8	15	30	40	60	90	150	200	250
	Burner air inlet pressure	[mbar]	45										
	Δp flange gas measurement	[mbar]	10										

MINIMUM CAPACITY

Free flame application			Burner model										
			EMB-0	EMB-1	EMB-2	EMB-3	EMB-4	EMB-5	EMB-6	EMB-7	EMB-8	EMB-9	EMB-10
Min capacity	Burner capacity(2% O ₂)	[kW]	2	3	8	15	30	40	60	90	150	200	250
	Combustion air flow	[Nm ³ /h]	2,2	3,3	8,8	16,5	33	44	66	99	165,5	220	275
	Gas flow	[Nm ³ /h]	0,2	0,3	0,8	1,5	3,0	4,0	6,0	9,0	15,0	20	25
	Burner air inlet pressure	[mbar]	0,5										
	Δp flange gas measurement	[mbar]	0,1										

NATURAL GAS CAPACITY TABLE

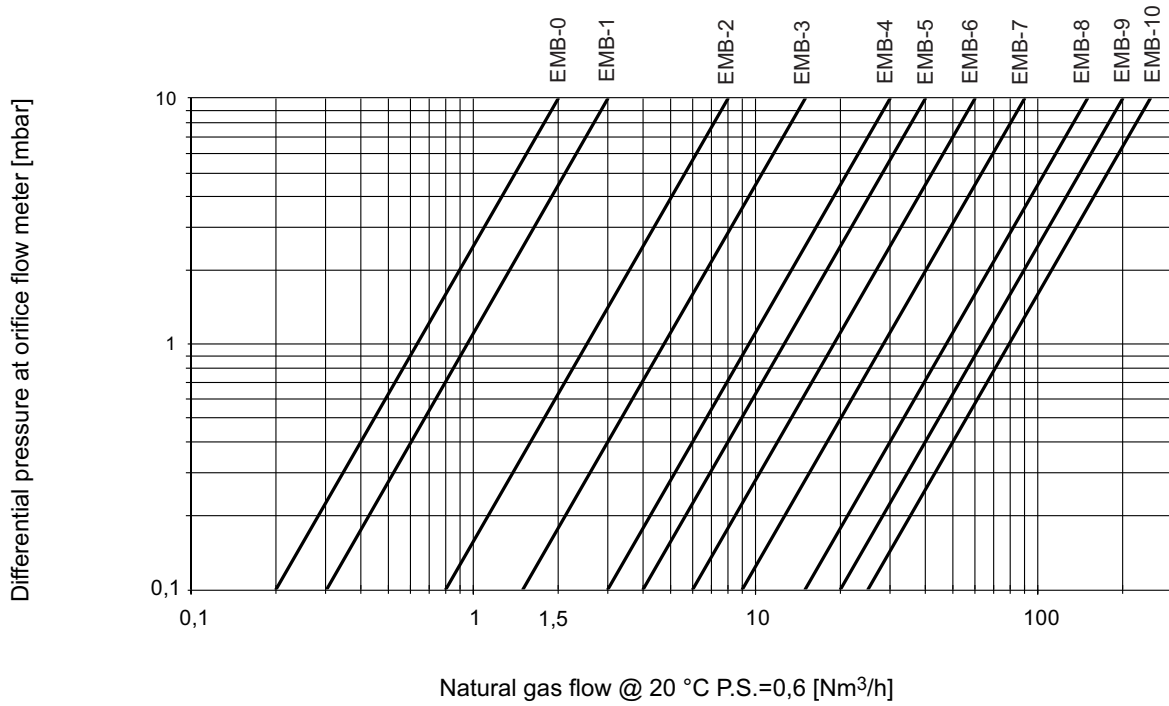

G3004I01

AIR CAPACITY TABLE

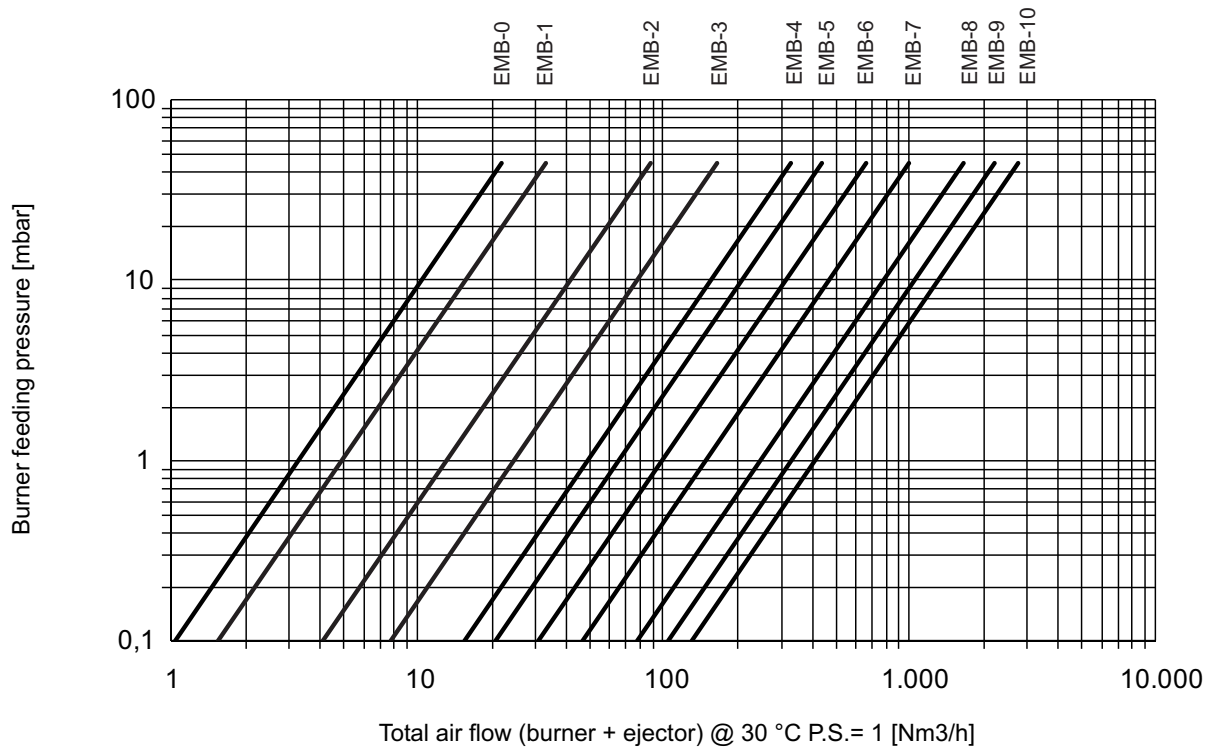

G3004I02

FLOW SCHEME -FREE FLAME METALLIC BURNER

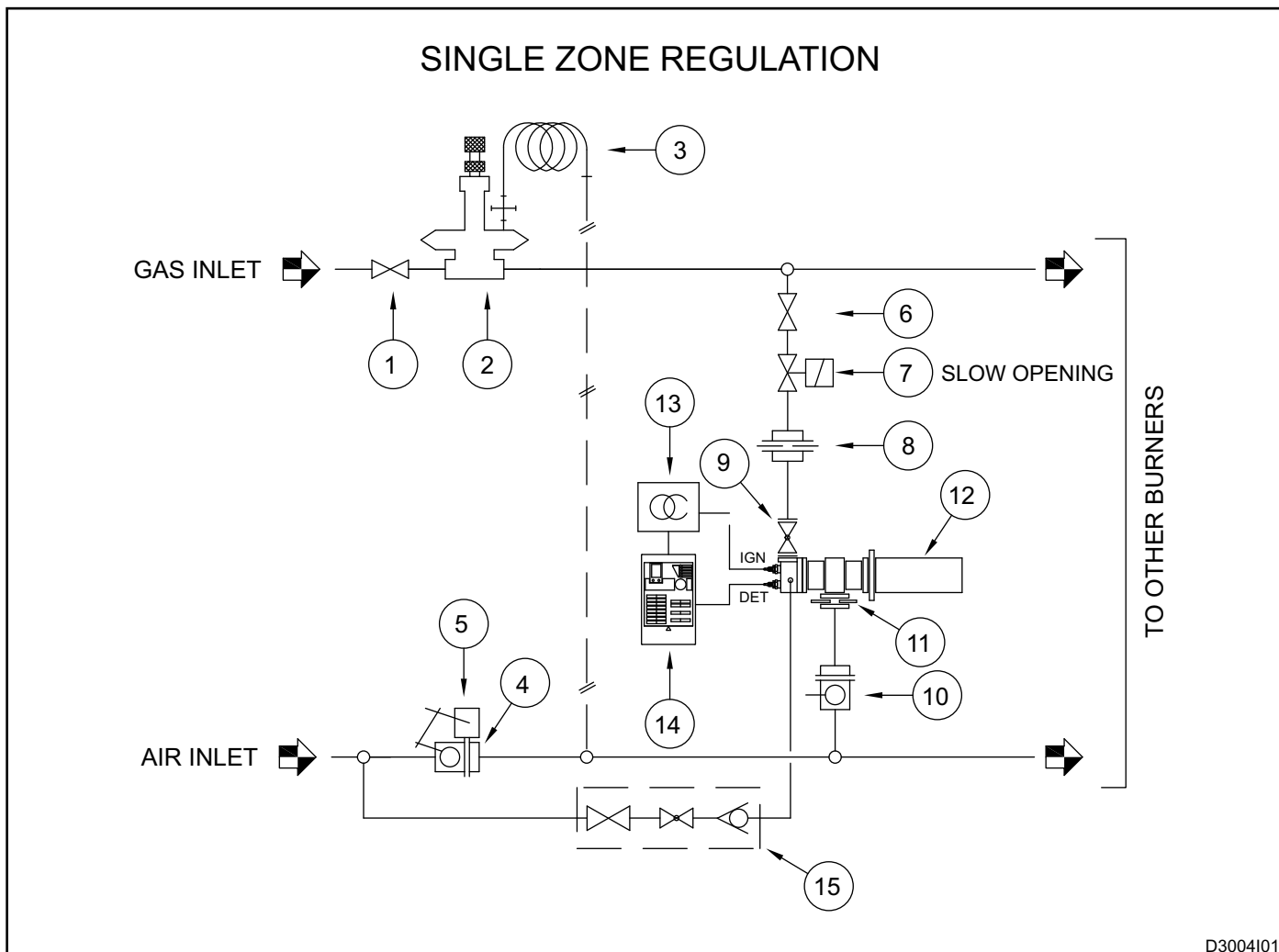

Pos.	Description	Included	Not included
1	Main gas interception ball valve		X
2	Balanced modulator		X
3	Impulse line		X
4	Servo-controlled air regulation butterfly valve		X
5	Electric servo-control		X
6	Single burner gas interception ball valve		X
7	Main burner safety gas solenoid valve		X
8	DP gas measurement calibrated flange	X	
9	Gas passage limiting device	X	
10	Manual air regulation butterfly valve		X
11	DP inlet air pressure measurement calibrated orifice		X
12	Free flame burner	X	
13	Ignition transformer		X
14	Flame control		X
15	Premix air regulation kit (only LPG versions)	X	

FLOW SCHEME -FREE FLAME METALLIC BURNER

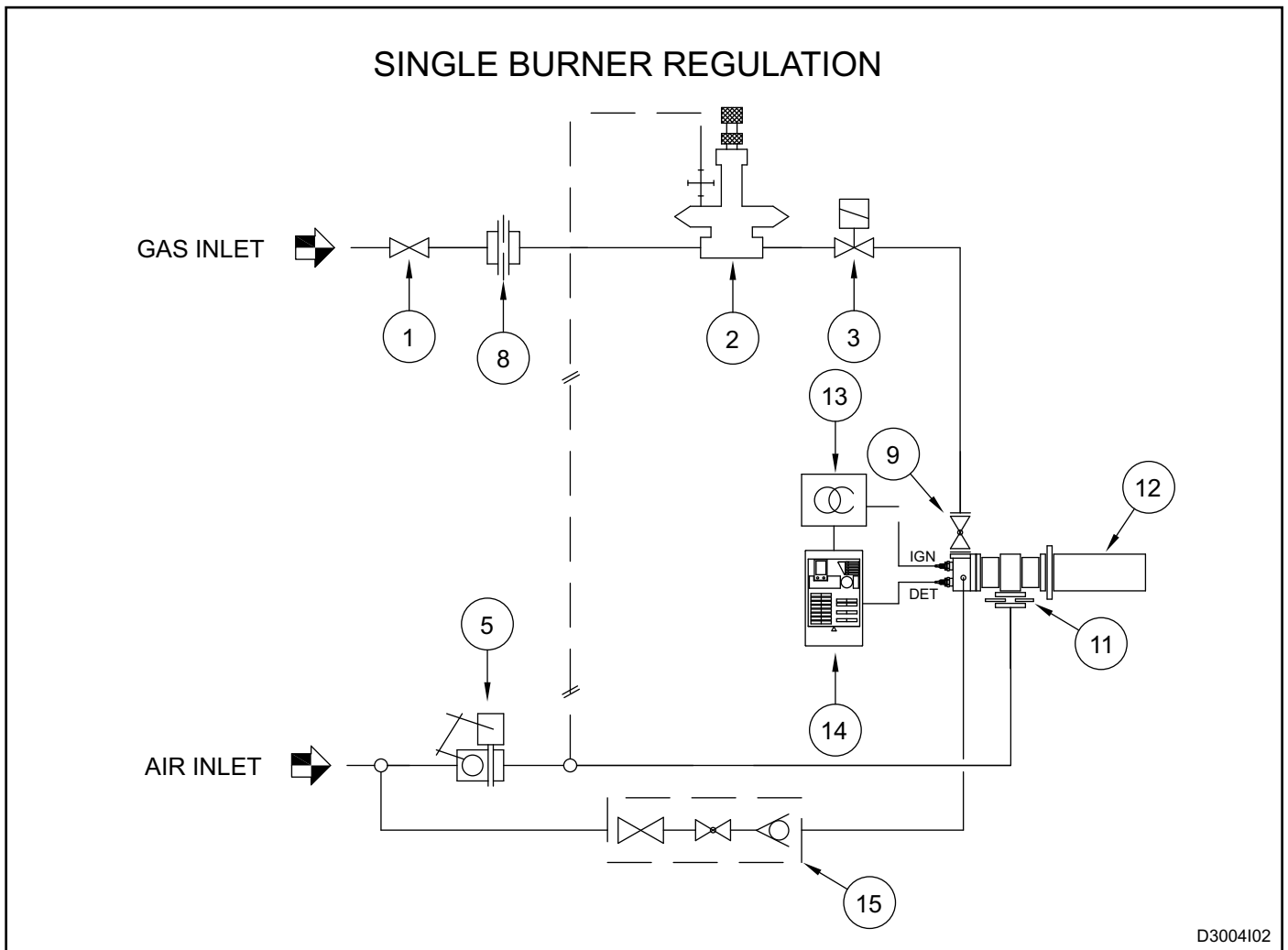

Pos.	Description	Included	Not included
1	Main gas interception ball valve		X
2	Balanced modulator		X
3	Impulse line		X
4	Servo-controlled air regulation butterfly valve		X
5	Electric servo-control		X
6	Single burner gas interception ball valve		X
7	Main burner safety gas solenoid valve		X
8	DP gas measurement calibrated flange	X	
9	Gas passage limiting device	X	
10	Manual air regulation butterfly valve		X
11	DP inlet air pressure measurement calibrated orifice		X
12	Free flame burner	X	
13	Ignition transformer		X
14	Flame control		X
15	Premix air regulation kit (only LPG versions)	X	

WARNINGS

- The EMB burner ignition must always be carried out at minimum power, modulating towards the maximum, facilitating the ignition and reducing the outlet overpressures. Thus it is opportune to use slow opening solenoid valves on the fuel line.
- The passing from minimum to maximum power and vice-versa, must be gradual and not instantaneous. In double stage regulations, the use of MRBV regulation valves (data sheet E1302) is suggested.
- For all low temperature applications (up to 750°C), the burner ignition and the fuel gas solenoid valve commands must be performed via a certified burner control device.
- To avoid possible damage to burners, make sure that the blower does not send them air that may be fouled by combustion products, oils, solvents or other. To avoid these phenomena from taking place, possibly install the blower or the suction duct outside the establishment and far from the exhaust pipes.
- Check the correct connection of the feeding lines after installation. Before switching the burner on, check that the combustive air and fuel gas pressure values are correct (**Pag.05**).
- The burner can only function within the indicated power range. Functioning at lower or higher powers could compromise the burner performance as well as its life span. In which case, the general warrantee conditions will automatically expire and ESA will not be held responsible for any damage to persons or things.
- If there is trouble with other devices during the burner start up phase, use the connector with anti disturbance filter for the high-tension (HT) cable connection of the ignition electrode.
- Avoid burner ignition close to each other so as not to heat the ignition command system devices (solenoid valves and transformers). Prewash time lapse + first safety time lapse + min. of 5 sec. = time lapse between one ignition and another. (however, do not attempt more than 2 ignitions during a 30sec. time lapse).
- Make sure the power supply is TURNED OFF when intervening on the burner and its devices. In case of burner malfunctioning, follow the indications in the 'Maintenance' chapter of the present manual or contact ESA-PYRONICS assistance.
- Any modification or repair done by third parties can compromise the application safety and automatically cause the general warrantee conditions to expire.

INSTALLATION

The EMB series burners are supplied with a special furnace wall fixing flange. The light obtained for the burner housing must leave open space around the burner. This space has then to be filled with ceramic-fibre.

For the installation carefully follow the instructions below:

1 - Place the EMB burners far from heat sources and products such as: liquids, solvents or corrosive gases.

2 - Make sure that the housing dimensions and the distance between the centers of the feeding pipes correspond to what is specified in the "Overall dimensions" chapter.

3 - Assemble the burner on the furnace wall (**pos. 01**) interposing a ceramic fibre gasket between the attachment flange and the furnace wall (**pos.02**) *. During the burner insertion phase check that the insulation previously wrapped around the outside is not altered nor damaged. Once the spacer has been fixed onto the furnace, from the inside of the combustion chamber, seal any possible cracks that may be left between the wall and the spacer with ceramic fibre.

4 - Connect the combustion air and fuel gas inlet piping, interposing, if possible, dilation joints in AISI.

5 - Connect electricity to the ignition electrode and to the uv-scan detector making sure not to pass the conductors near heat sources.

6 - Check that the burner body and all its metallic elements are earthed with appropriate conductors.

7 - The connecting cable from the ignition transformer to the electrode must be specific for high tension and not screened. It must not be more than 1 metre long; otherwise the ignition transformer must be positioned near the burner. The high tension cable must be placed far from the power cables and not in metallic ducts. Ideally it should be left in open air.

8 - For further information please consult the technical data sheet concerning the ignition transformers.

9 - Connect electricity to the ignition electrode and to the uv-scan detector making sure not to pass the conductors near heat sources.

NOTE: * The furnace wall seal, unless specifically requested by the customer, is not included in the burner supply.

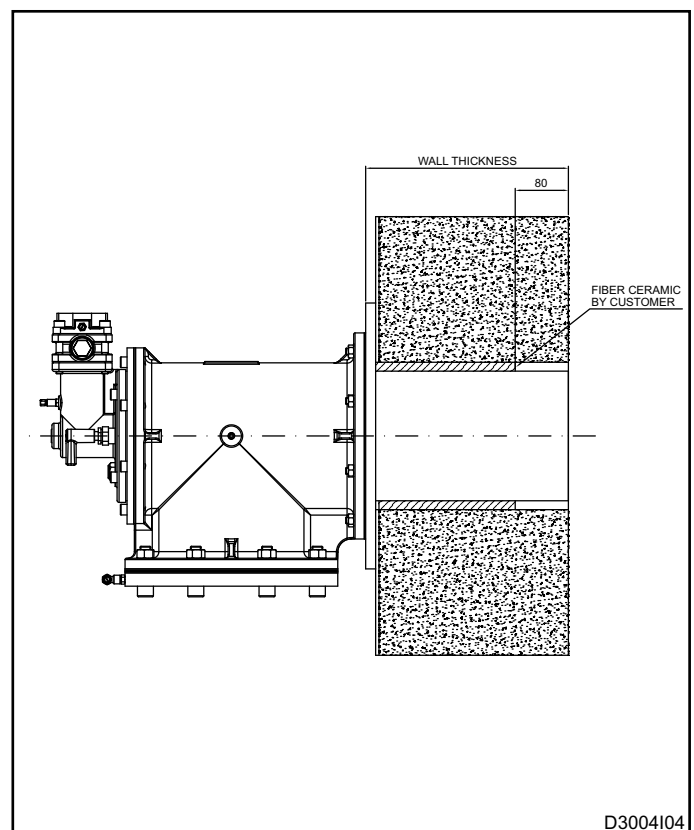
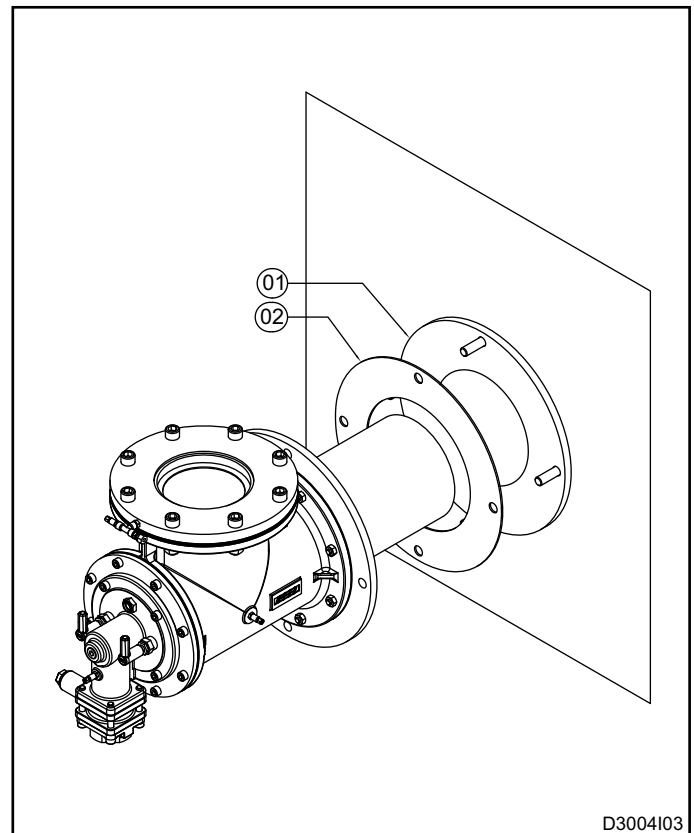

START-UP - SETTING

The procedures indicated in the following chapter must be carried out by expert technicians. The non-observance of the instructions given can provoke dangerous conditions.

1 - Check that the combustion air pressure exiting the blower and the combustive fuel feeding pressure are both within the allowed range.

2 - Adjust the working pressure and the safety device pressure of the combustion plant, whether there is one per burner or one for the whole plant i.e. gas pressure reduction gear, block valve, relief valve, pressure switches etc. Simulate the intervention of all the safety devices including the intervention of the safety over temperature, checking that the fuel safety block devices act properly.

3 - Place the motorized air regulation valve in its maximum opening position and, via the gate valve, regulate the inlet air pressures to the burner, referring to the values indicated in the "burner performance" chapter for the maximum capacities (**pag.05**).

4 - Place the motorized air regulation valve in its minimum opening position and regulate its opening to obtain (in burner and ejector inlet) the relative minimum power pressure.

5 - Activate the burner control device and attempt the ignition until the burner switches on. While attempting to ignite the burner, act on the gas adjustment valve and, starting from the totally closed position, open it gradually until the burner ignites.

6 - Fully open the air regulation valve and adjust the maximum fuel capacity via the gas adjustment valve, checking the differential pressure created on the calibrated gas flange.

7 - Double check that, at minimum and maximum power, the burner inlet pressure corresponds to the values in the "Parameter capacity" chapter. These values may be different depending on whether the burner is on or off.

8 - If necessary, with all burners turned onto the same power, analyse the combustion products in the chamber (where possible).

9 - Repeatedly attempt ignition at minimum burner power, with maximum amplitude, to check the ignition reliability and flame stability during the adjustment.

PREMIX AIR FLOW SETTING WHERE SCHEDULED (LPG BURNERS)

The premix line is supplied with the LPG burners. The setting must be carried out with burner off and in minimum flow conditions. The premix line must be fed by an inlet necessarily placed upstream the air flow regulation valve, whether it is in zone or interlocked by the main burner.

1. Place the burner in the minimum combustion air flow conditions.

2. Open the premix air tap.

3. Regulate the micrometric pin valve according to the following conditions:

4. Check, however, that at minimum power, the burner does not create black smoke on the combustion head and on the electrodes. In case this should occur, increase the premix air setting.

EMB-1: Gas body pressure = 2 mbar

EMB-2: Gas body pressure = 2 mbar

EMB-3: Gas body pressure = 2 mbar

EMB-4: Gas body pressure = 2 mbar

EMB-5: Gas body pressure = 2 mbar

EMB-6: $\Delta p = 6.5$ mbar

EMB-7: $\Delta p = 2.5$ mbar

EMB-8: $\Delta p = 5$ mbar

EMB-9: $\Delta p = 5$ mbar

EMB-10: $\Delta p = 5$ mbar

GENERAL MAINTENANCE PLAN

Operation	Type	Advised time	Notes
High tension electrode connection	O	annual	check integrity of outer plastic and oxidation of internal electrode terminal.
Electrode ignition / detection	O	annual	replace if the kantal terminal is worn.
Flanged tube combustion head	O	annual	during furnace stop, check that the two elements do not show signs of oxidation caused by high temperature.
Burner setting	O	annual	check the correctness of air and gas pressures or oxygen content with a suitable analyzer.
Premix air setting (where scheduled)	O	annual	check the correctness of the calibration of the premix line with the burner off.
Replacement of gas side gaskets (**)	S	biennale	check that the gaskets are free of air leaks and that there is no vulcanization in the rubber.

NOTES:

Key: O=ordinary / E=extraordinary

(*) it is suggested that the gaskets on the gas side are replaced after every disassembly of the gas feeding line.

(**) use high temperature gaskets

ORDINARY MAINTENANCE

For correct dismantling and better maintenance of the EMB burner, meticulously follow the instructions below with the plant turned off.

IGNITION AND FLAME DETECTION ELECTRODE REPLACEMENT

1 - Check that the burner control device is disconnected.

2 - Disconnect electrical supply to the electrodes (**pos.01**).

3 - Unscrew the connector (**pos.02**) at the base of the gas collector, removing the electrode (**pos.03**).

4 - Replace the faulty electrode (**pos.03**) paying attention to the correct repositioning of the new electrode.

5 - Reconnect the electrical supply (**pos.01**).

6 - Check the electrode's correct flame ignition/detection.

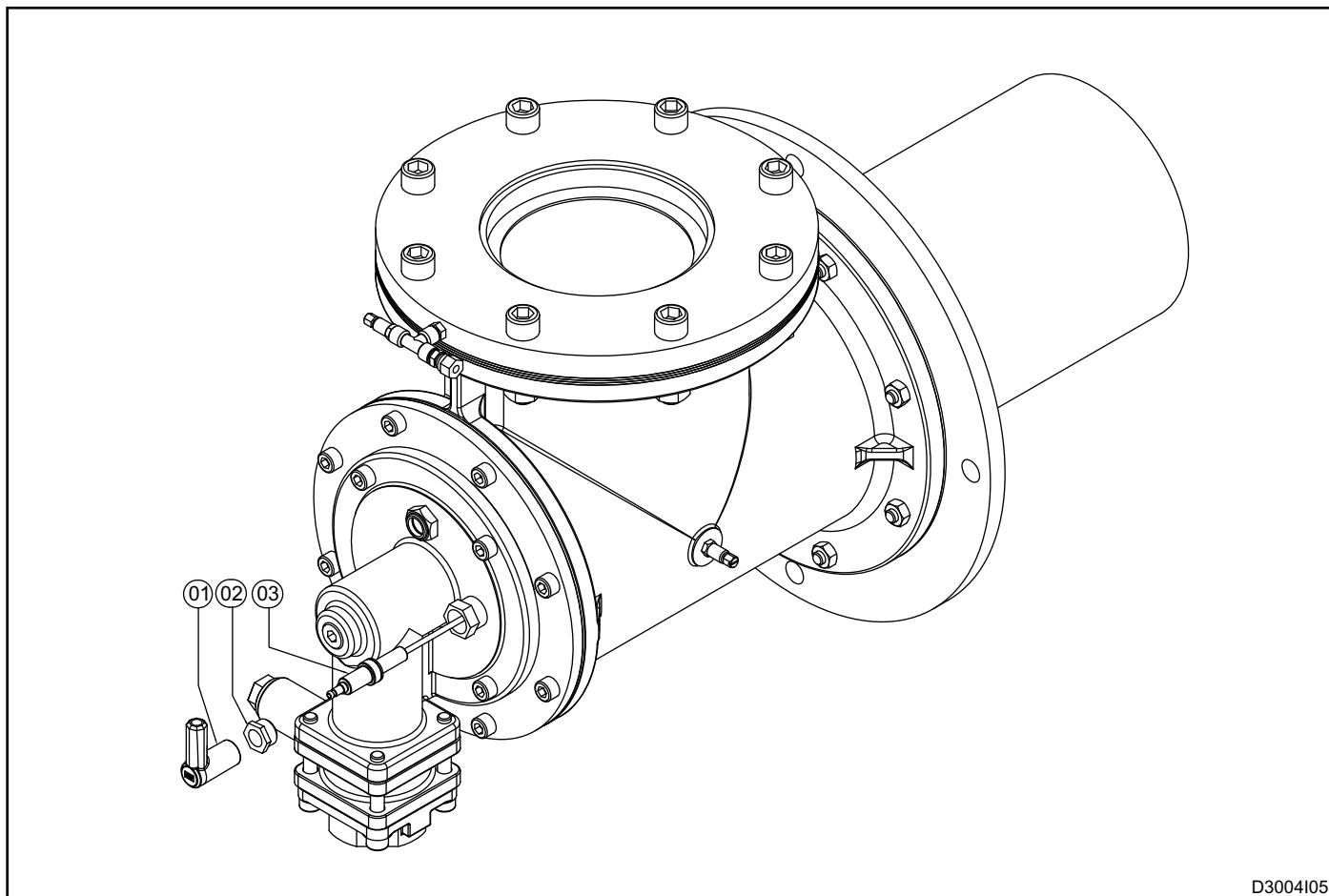

D3004105

EXTRAORDINARY MAINTENANCE

For correct dismantling and better maintenance of the EMB burner, meticulously follow the instructions below with the plant turned off.

BURNER-SHUTDOWN

For correct dismantling and better maintenance of the EMB burners, meticulously follow the instructions with the plant turned off. In shutdown conditions of the burner refer to the burner control device indications and to the relative manual to identify the cause. The main cases are indicated here below:

■ **Illegal flame detection:** the shutdown is due to an illegal flame detection during the phases prior to ignition or after the turning off. The causes are within the detection system (broken or faulty sensor or presence of humidity), or in the gas draw from the solenoid safety valve, which allows the burner to remain turned on.

■ **Failed ignition:** shutdown is caused due to the fact that no flame has been created during the starting process. The causes can be found in the start-up system (spark absence, faulty electrodes or incorrect position), in the bad setting of the fuel and combustion flow or in the detection system (faulty sensor or interrupted cables). More precisely, in the first two cases the flame is not ignited, while in the last case the flame is created but the burner control device is unable to detect it.

■ **Flame signal loss:** shutdown due to the loss of flame signal during the normal functioning of the burner. The causes can be found in the combustion air flow adjustment (rapid flow variations, adjustment out of allowed range). They can also be found in the detection system (faulty, dirty or badly positioned sensors).

EMB-0 OVERALL DIMENSIONS

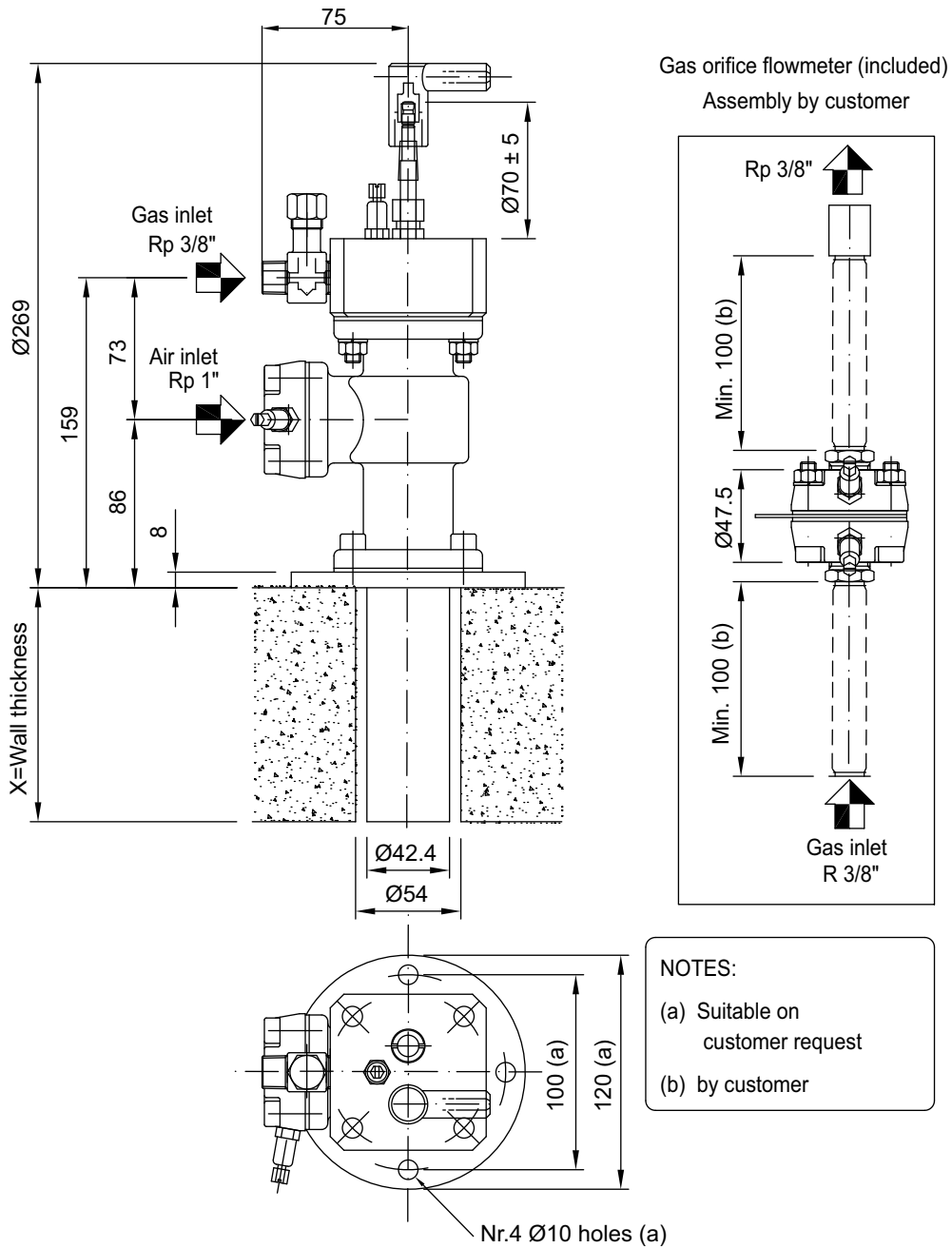

EMB-1-CH4 OVERALL DIMENSIONS

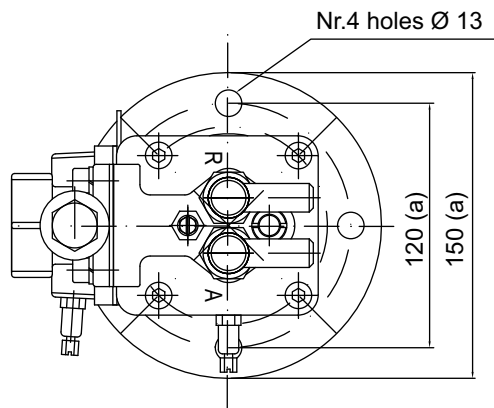
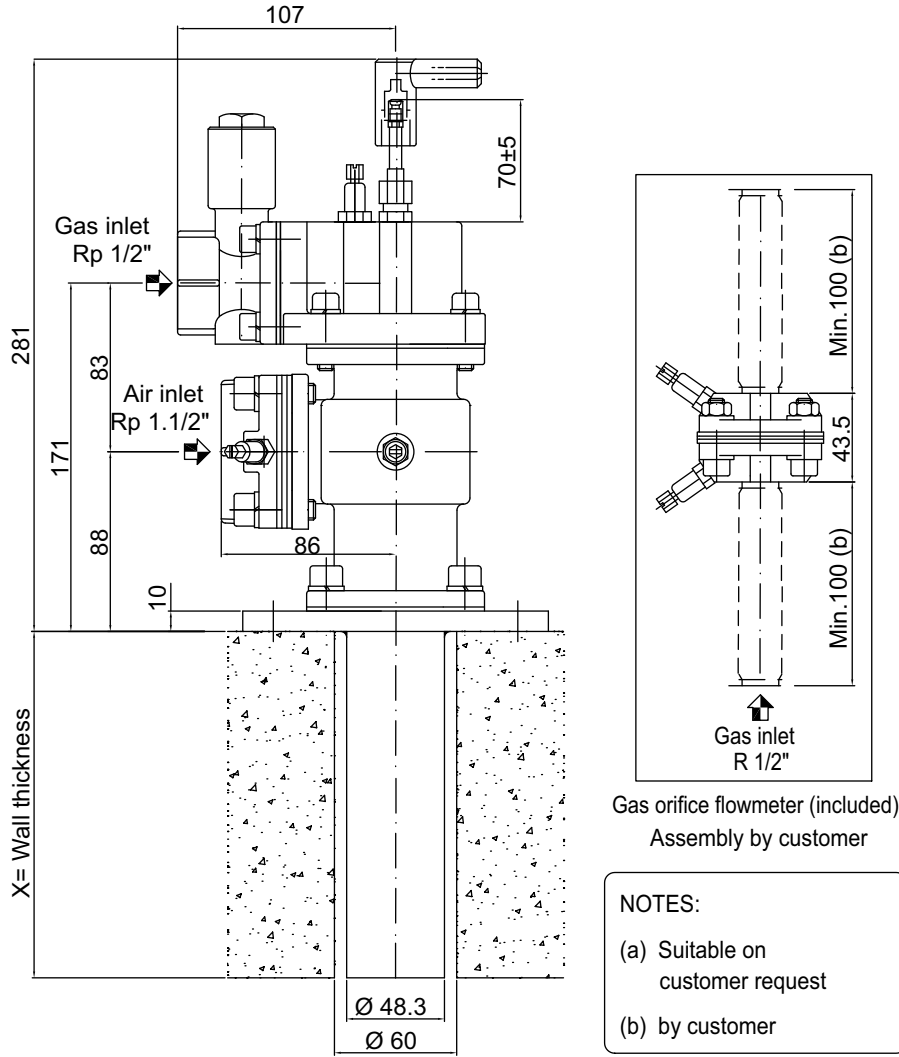

EMB-1 LPG OVERALL DIMENSIONS

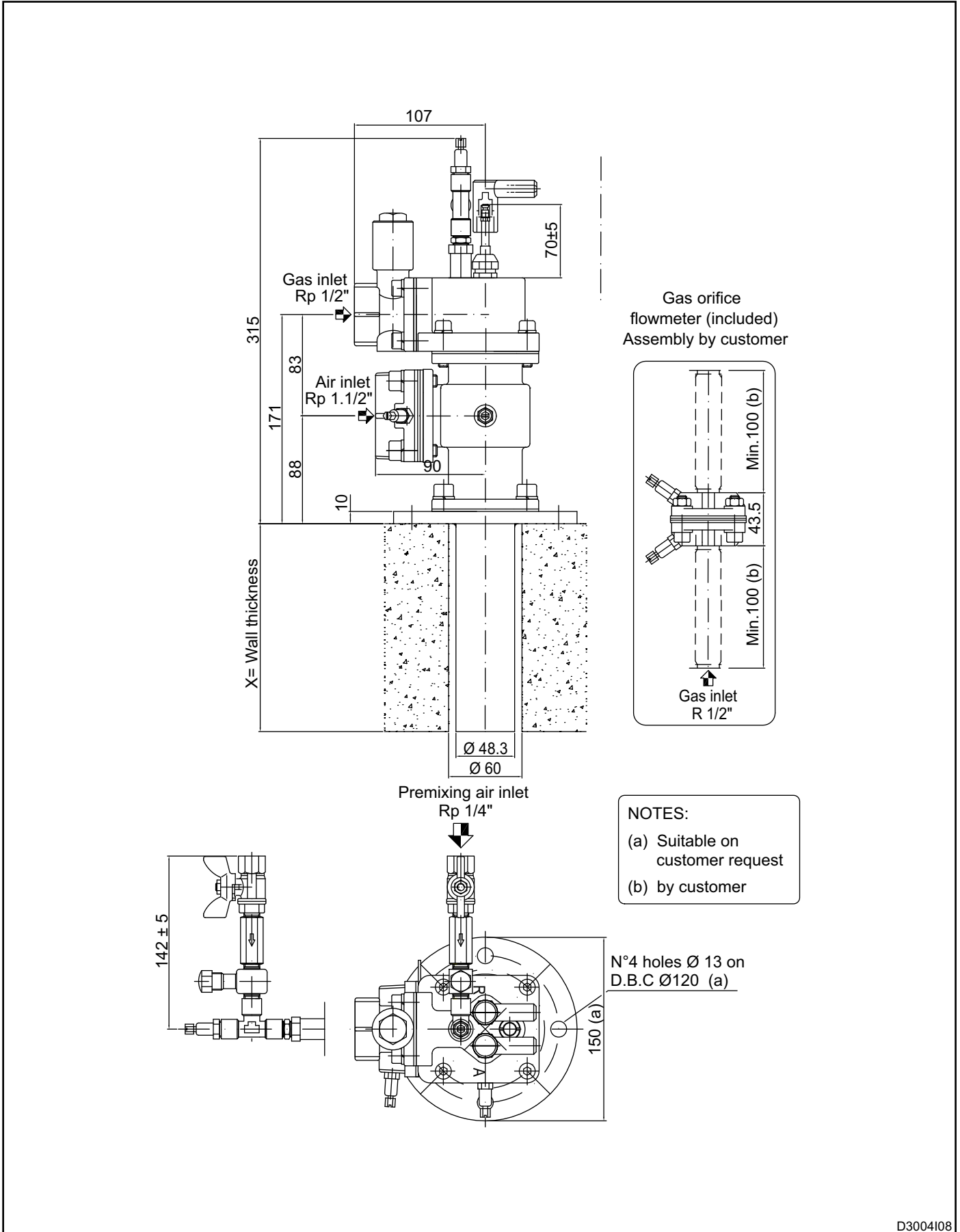

D3004108

EMB-2-CH4 OVERALL DIMENSIONS

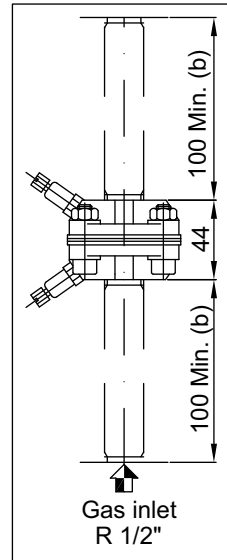
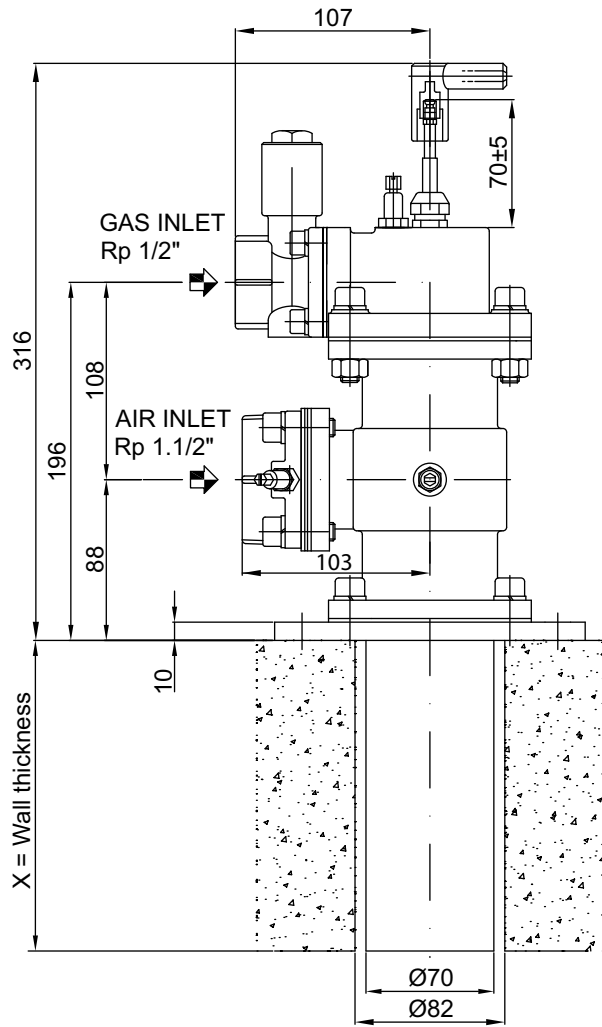

Gas orifice flowmeter (included)
Assembly by client

NOTES:

- (a) Suitable on client request
- (b) by client

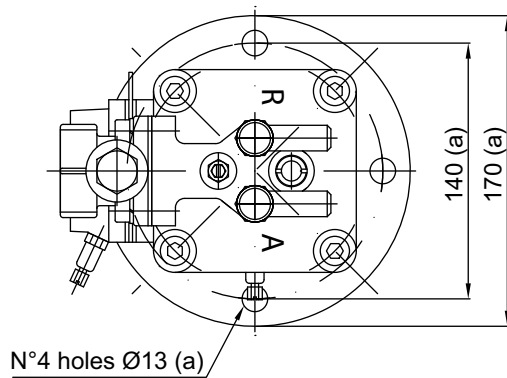

EMB-2 LPG OVERALL DIMENSIONS

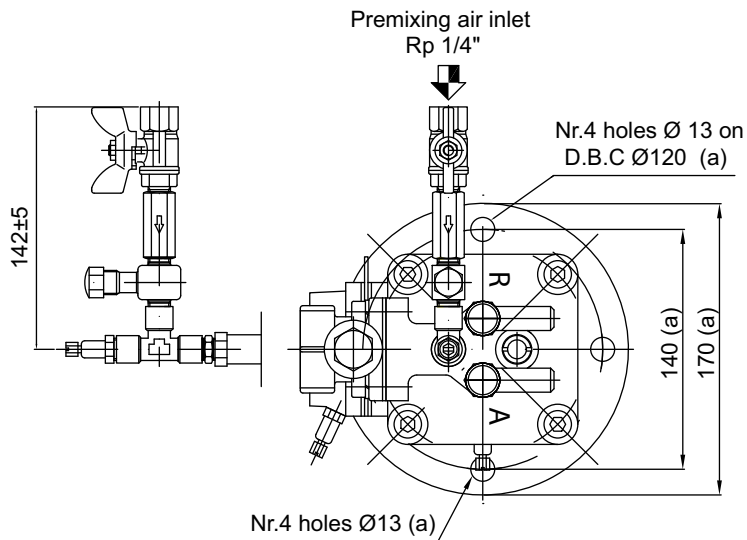
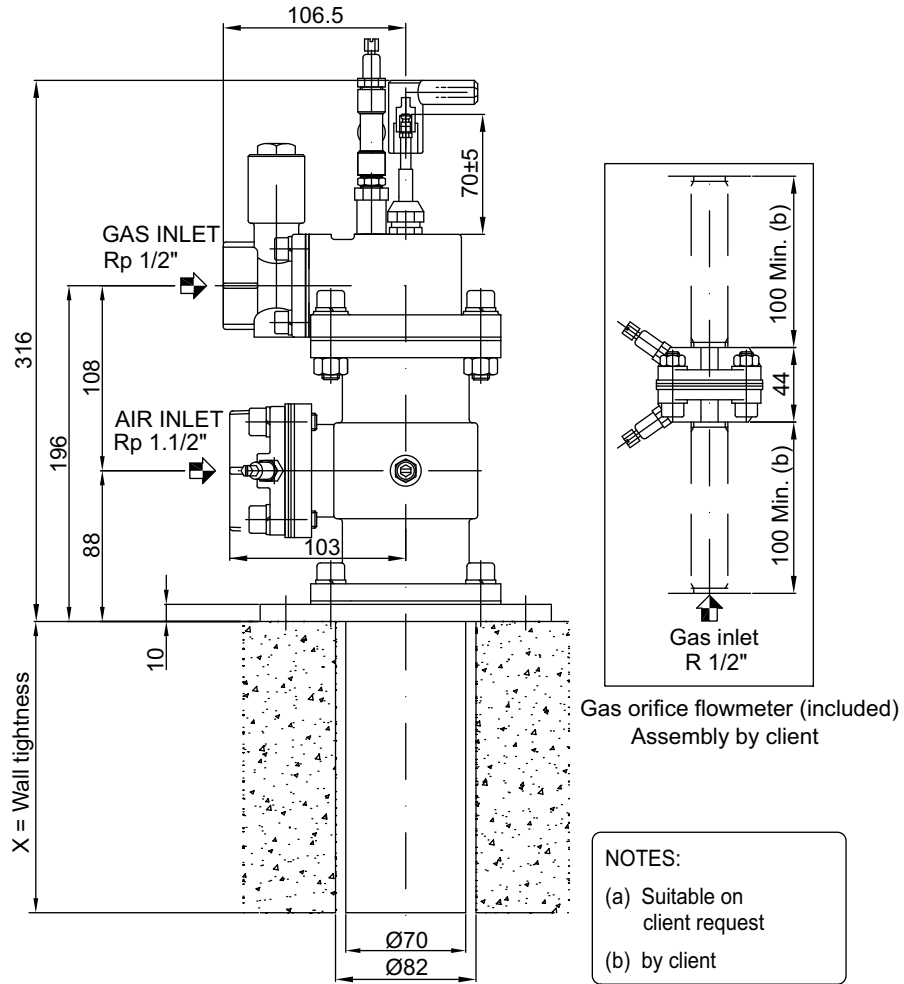

EMB-3-CH4 OVERALL DIMENSIONS

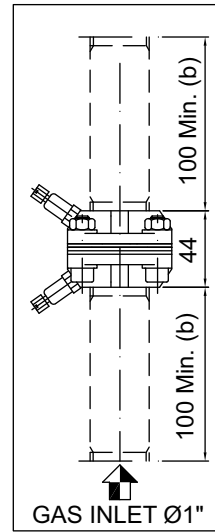
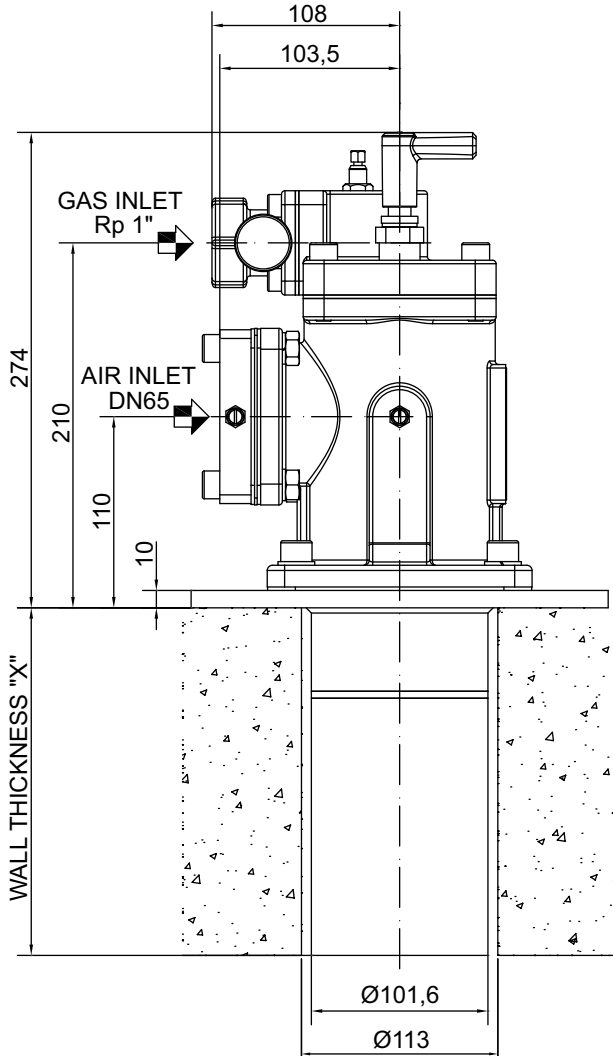

Gas orifice flowmeter (included)
Assembly by client

NOTES:

- (a) Suitable on client request
- (b) by client

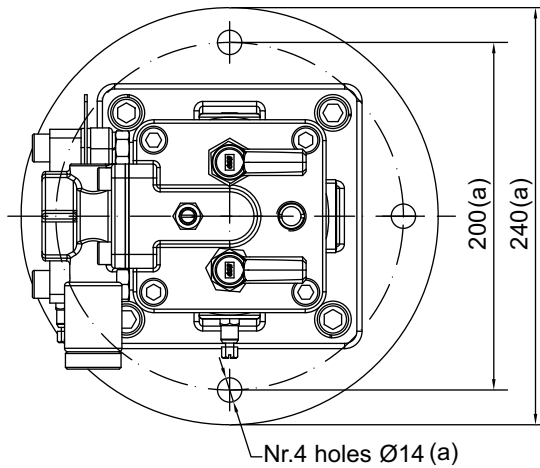

EMB-3 LPG OVERALL DIMENSIONS

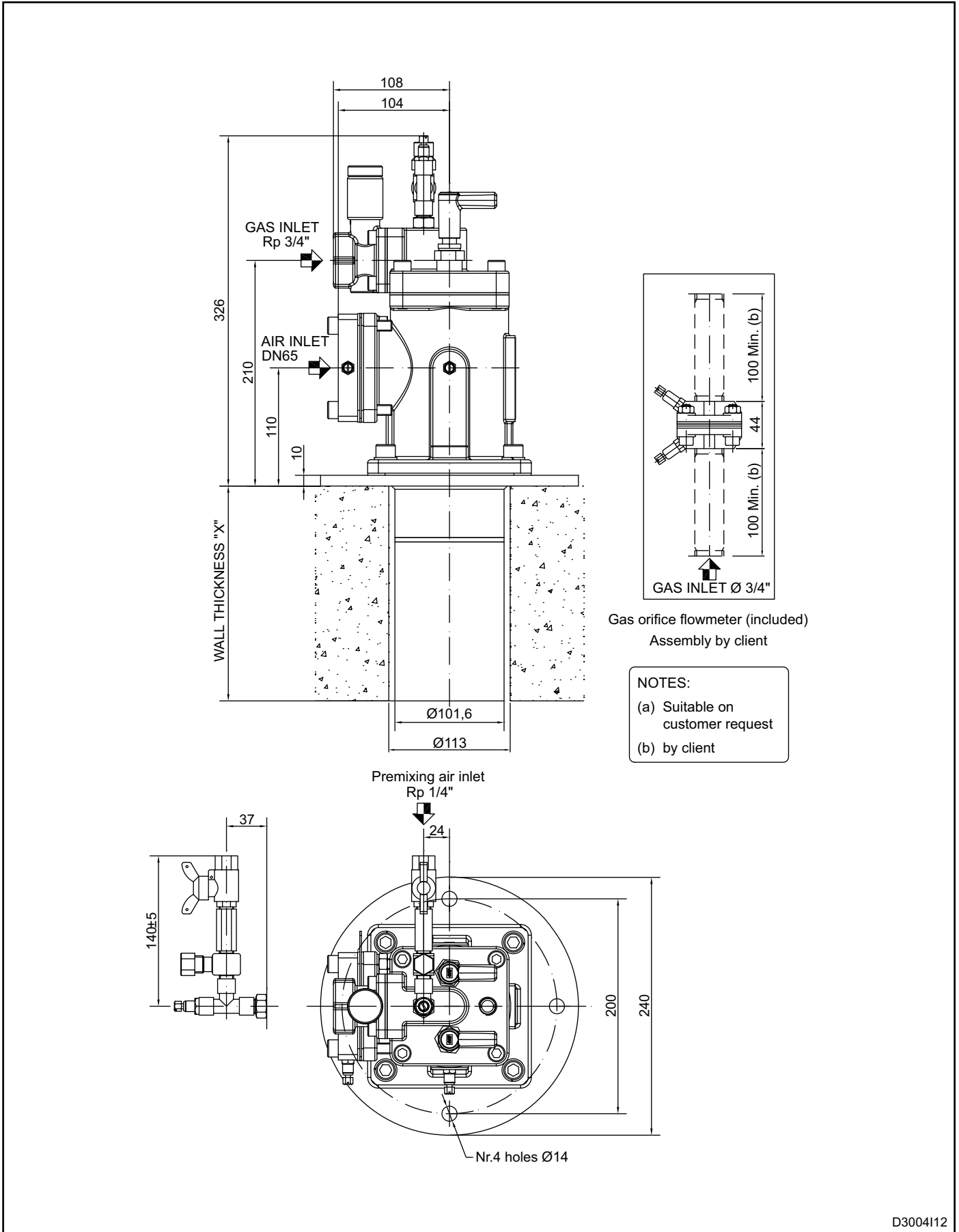

D3004I12

EMB-4-CH4 OVERALL DIMENSIONS

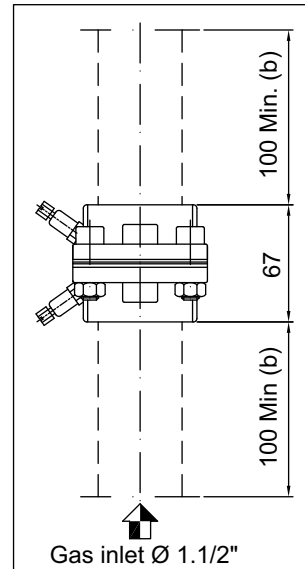
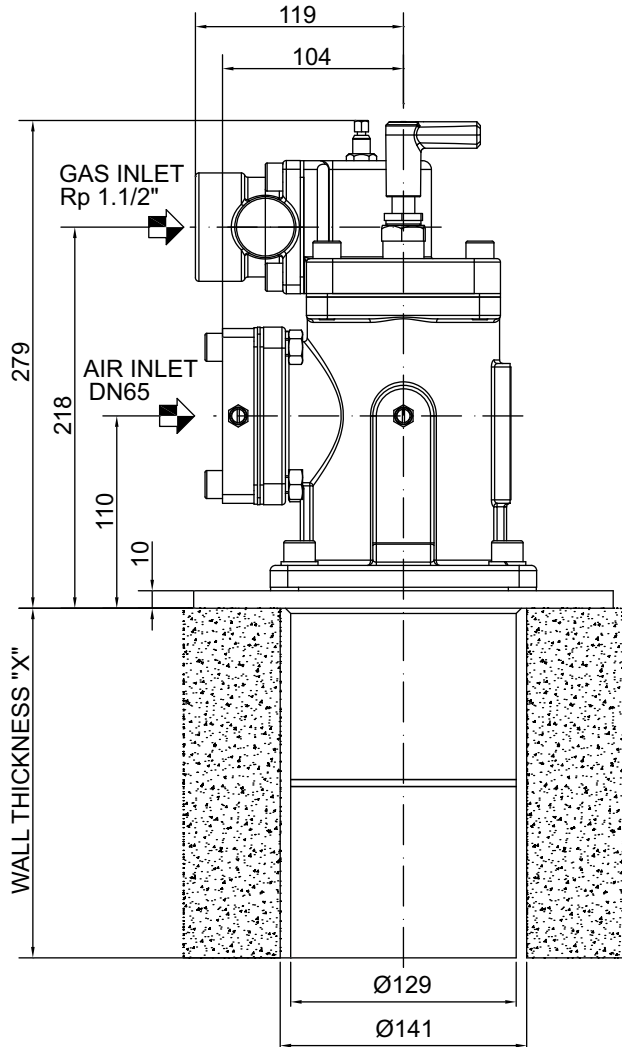

Gas orifice flowmeter (included)
Assembly by client

NOTES:

- (a) Suitable on client request
- (b) by client

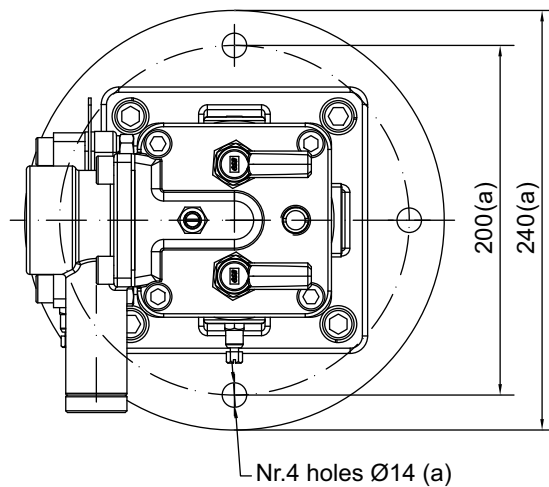

EMB-4 LPG OVERALL DIMENSIONS

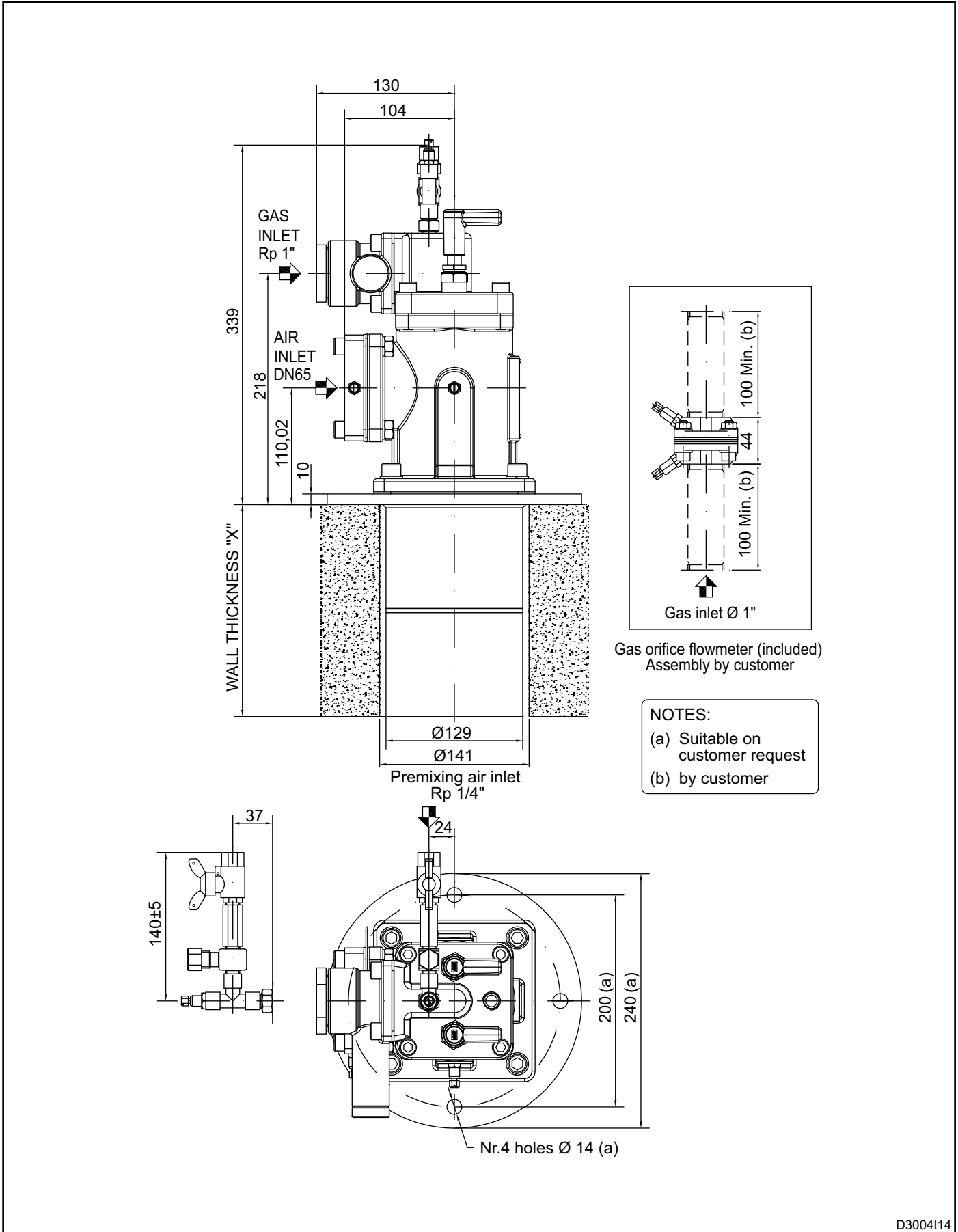

D3004114

EMB-5-CH4 OVERALL DIMENSIONS

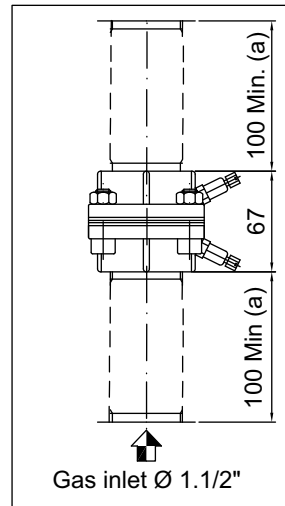
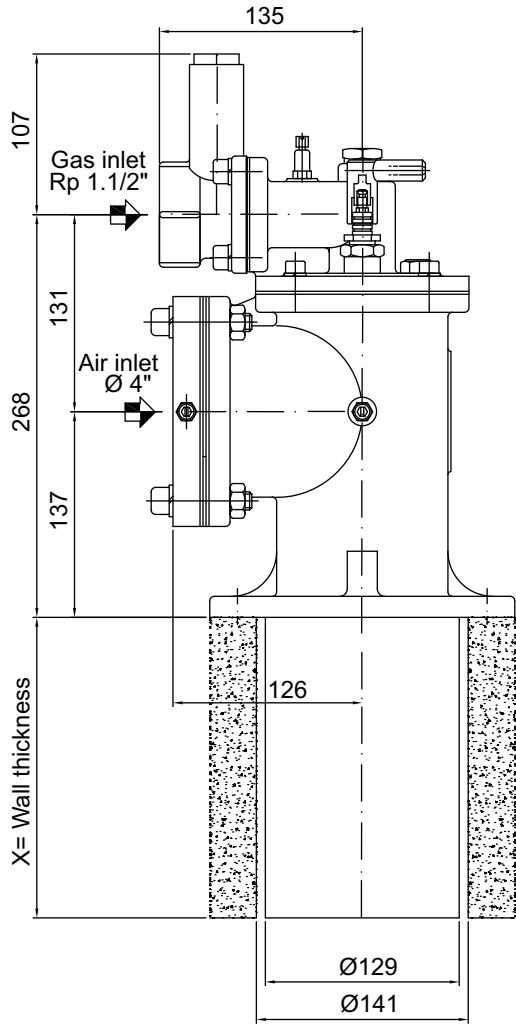

Gas orifice flowmeter (included)
Assembly by customer

NOTES:
(a) by customer

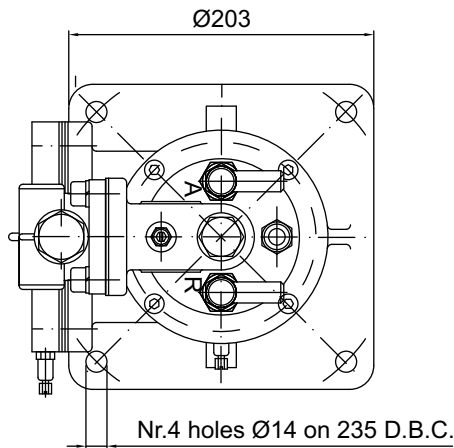

EMB-6-CH4 OVERALL DIMENSIONS

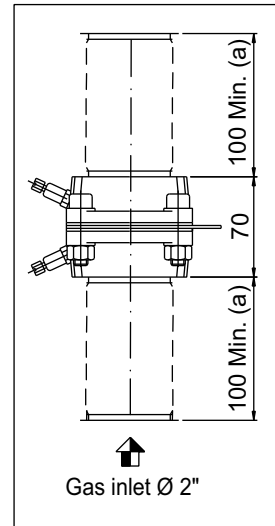
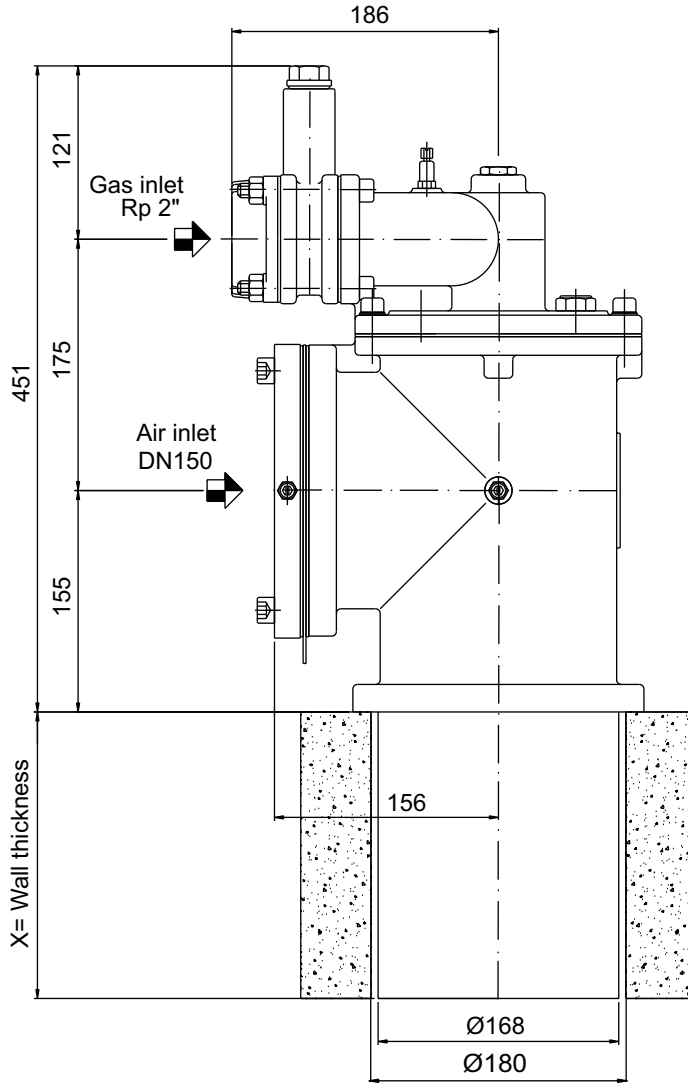

Gas orifice flowmeter (included)
Assembly by customer

NOTES:
(a) by customer

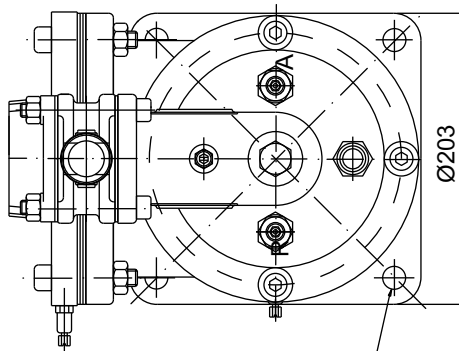

Nr.4 holes $\varnothing 14$ on 235 D.B.C.

EMB-6 LPG OVERALL DIMENSIONS

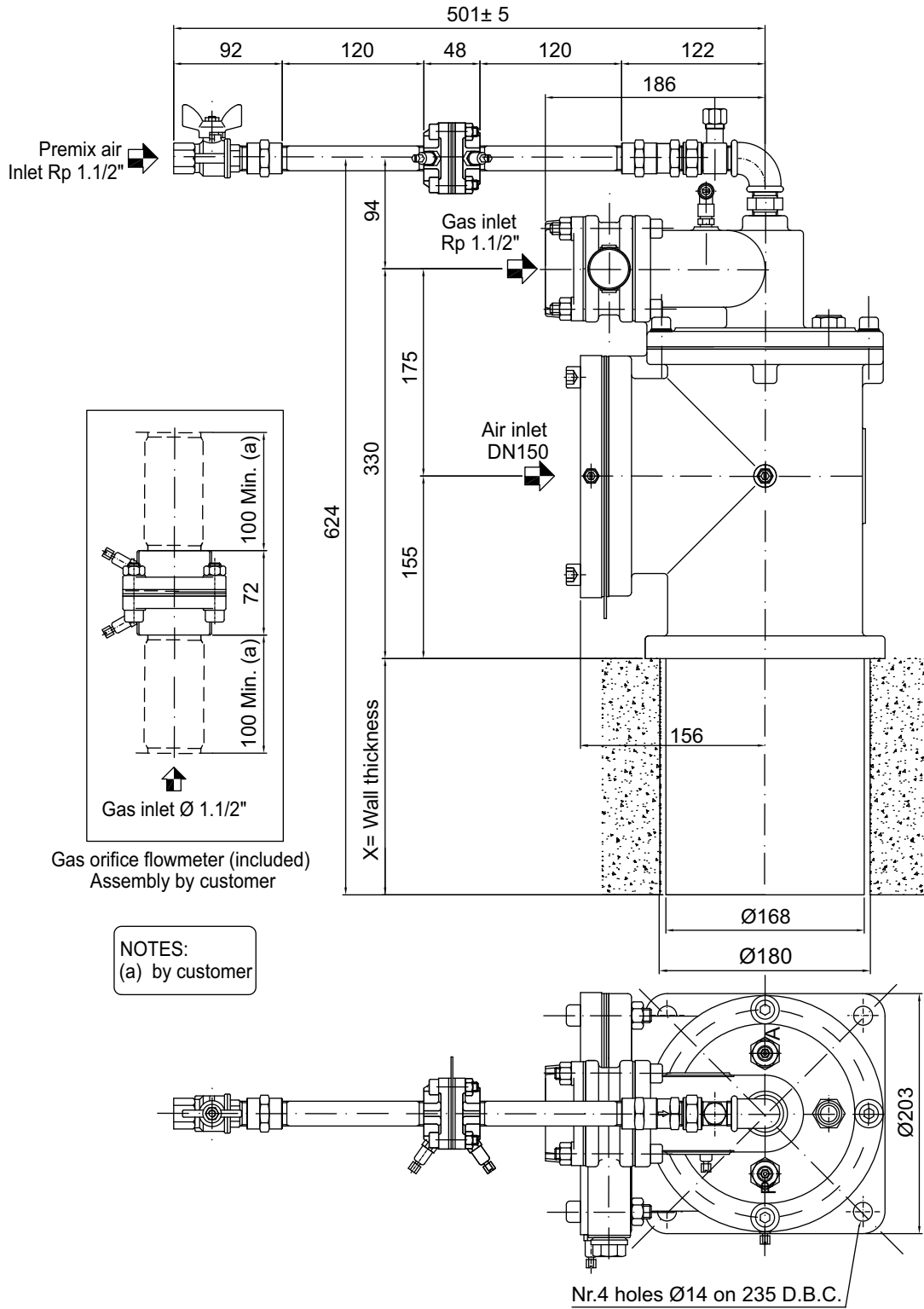

NOTES:
(a) by customer

EMB-7-CH4 OVERALL DIMENSIONS

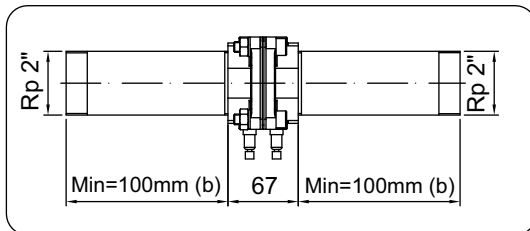
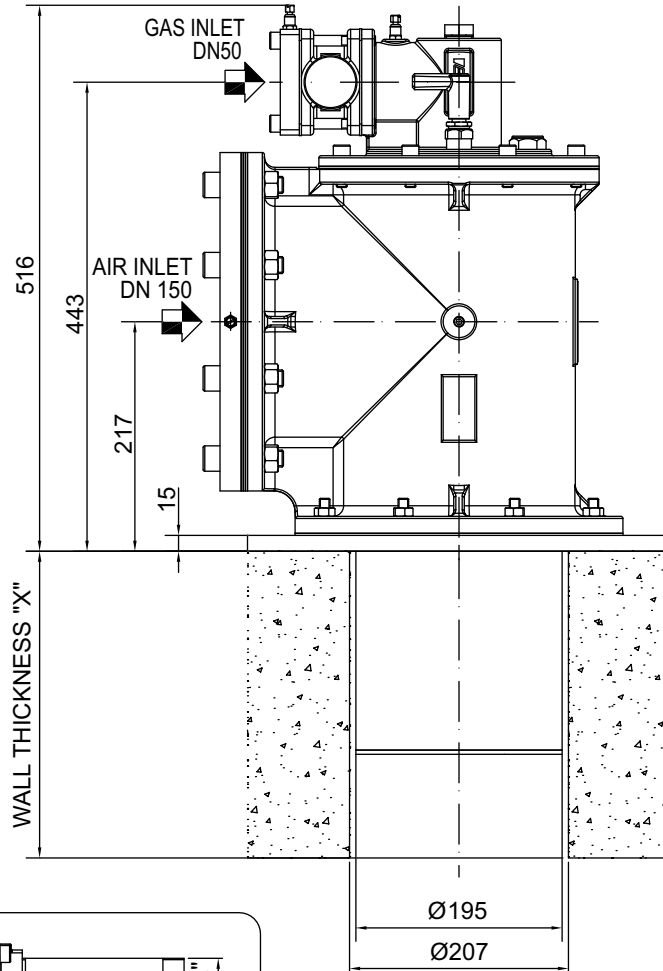

Gas orifice flowmeter (included)
Assembly by client

NOTES:
(a) Suitable on client request
(b) by client

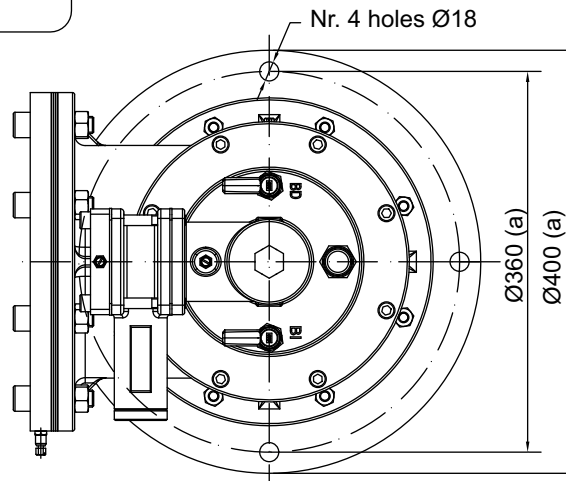

EMB-7 LPG OVERALL DIMENSIONS

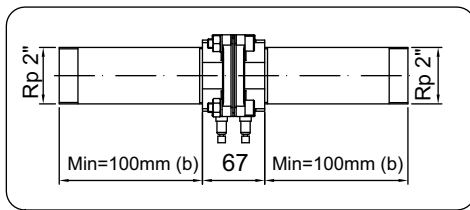
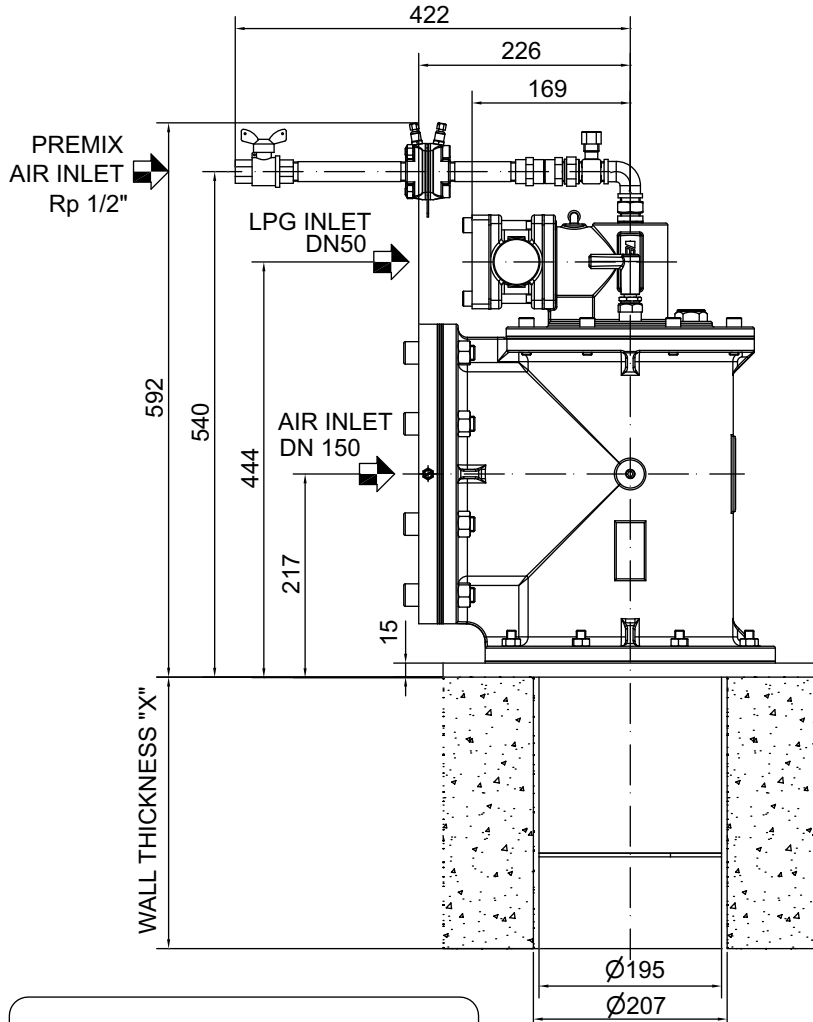

Gas orifice flowmeter (included)
Assembly by client

NOTES:
(a) Suitable on client request
(b) by client

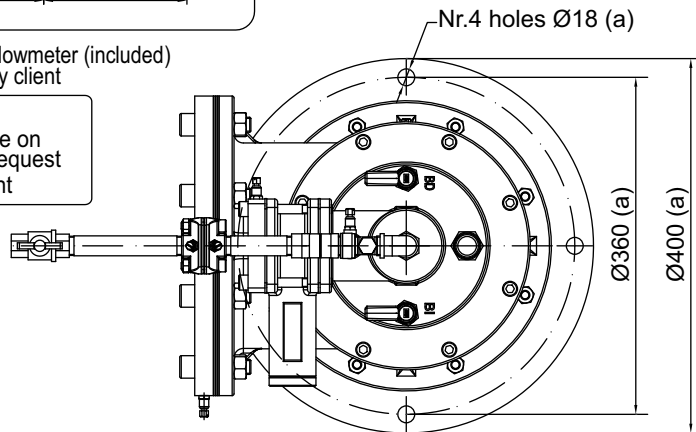

EMB-8-CH4 OVERALL DIMENSIONS

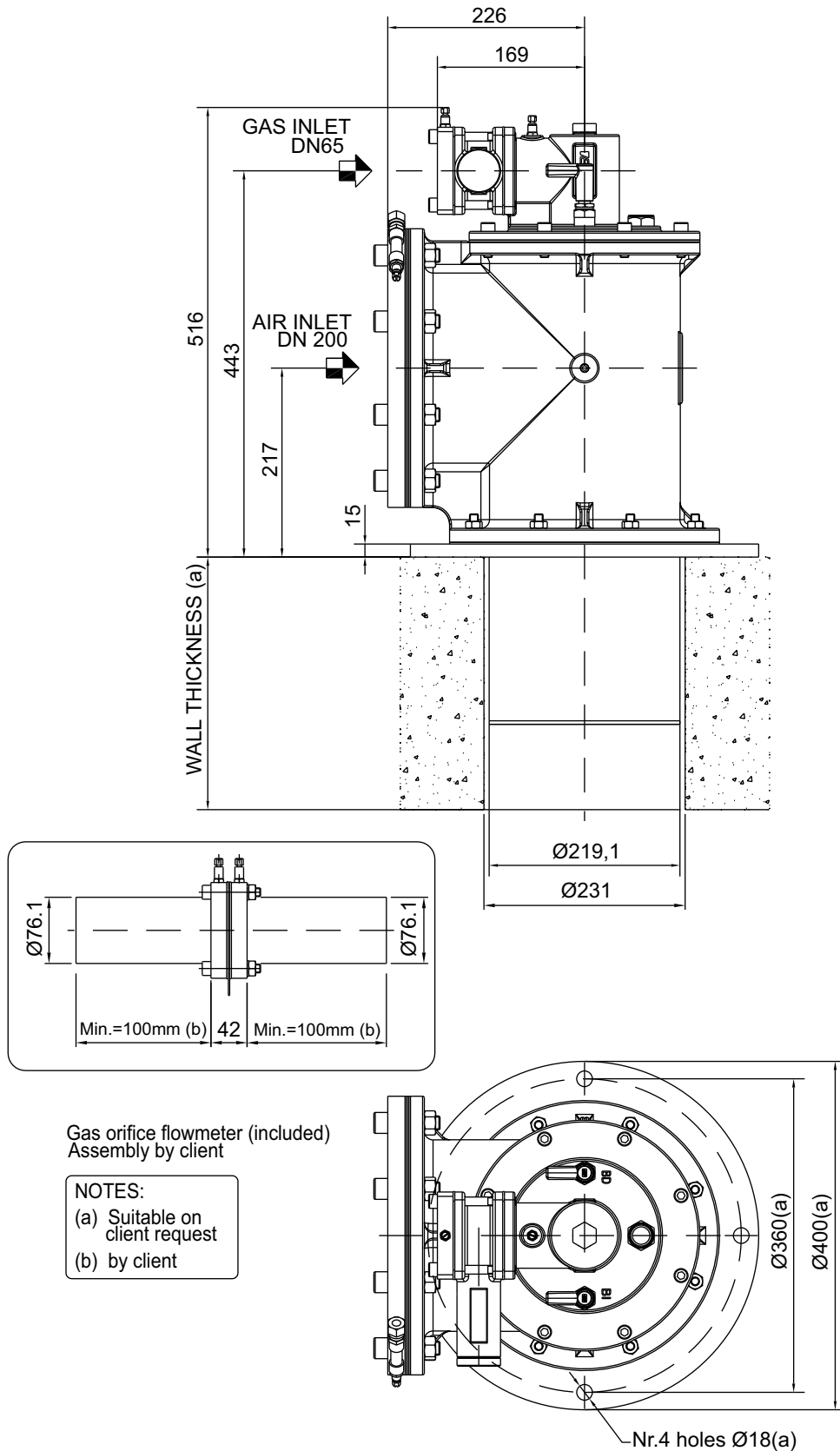

D3004I21

EMB-8 LPG OVERALL DIMENSIONS

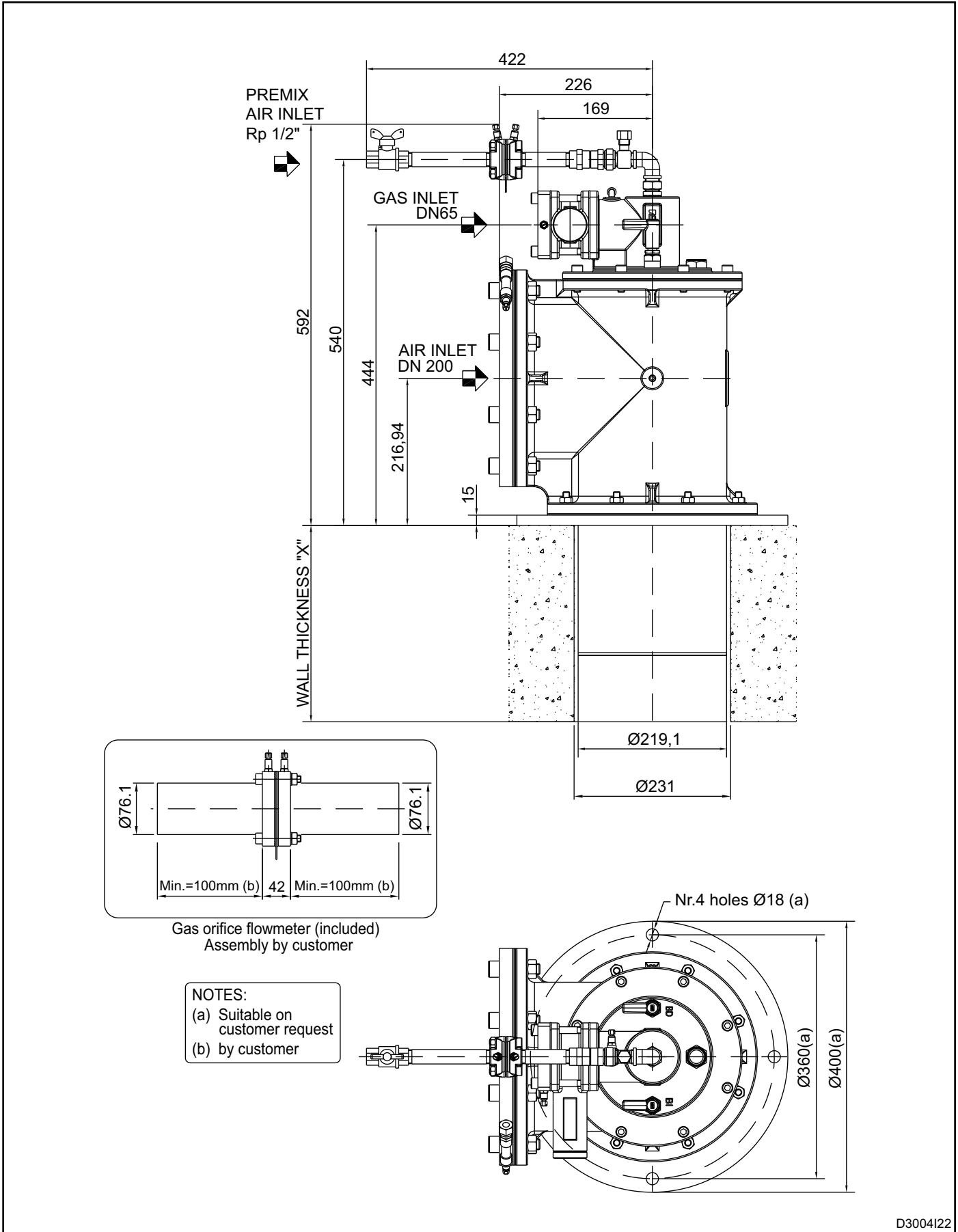

D3004I22

EMB-9 CH4 OVERALL DIMENSIONS

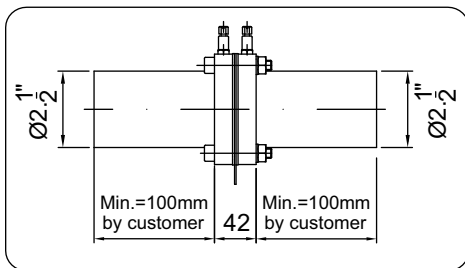
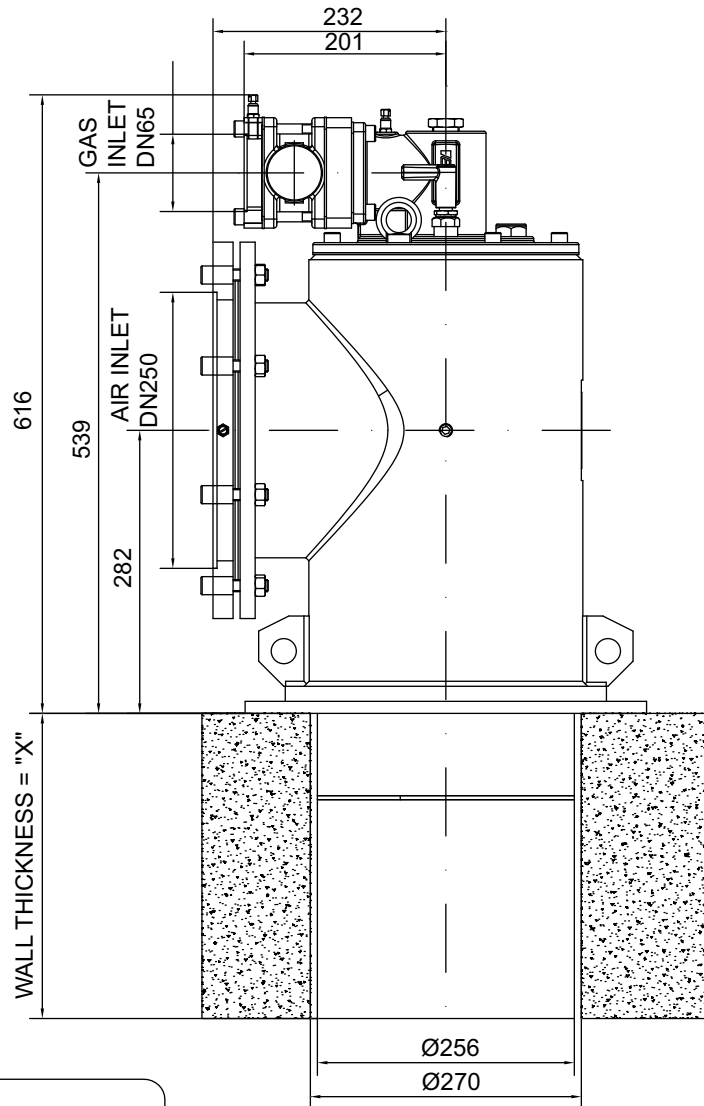

Gas orifice flowmeter (included)
Assembly by customer

NOTES:
(a) Suitable on customer request
(b) by customer

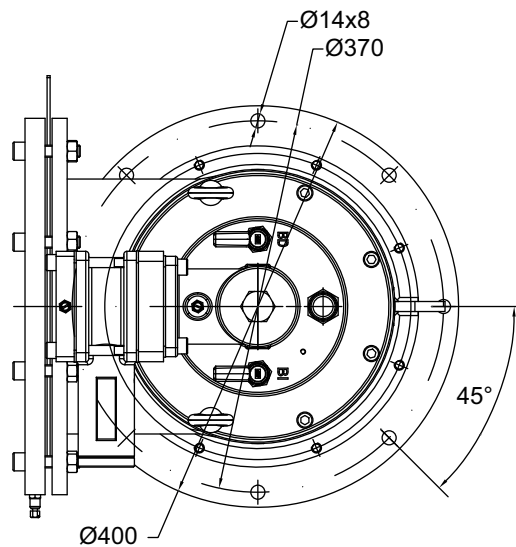

EMB-9 GPL OVERALL DIMENSIONS

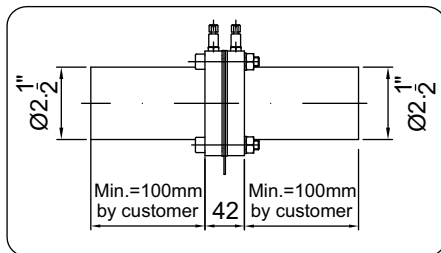
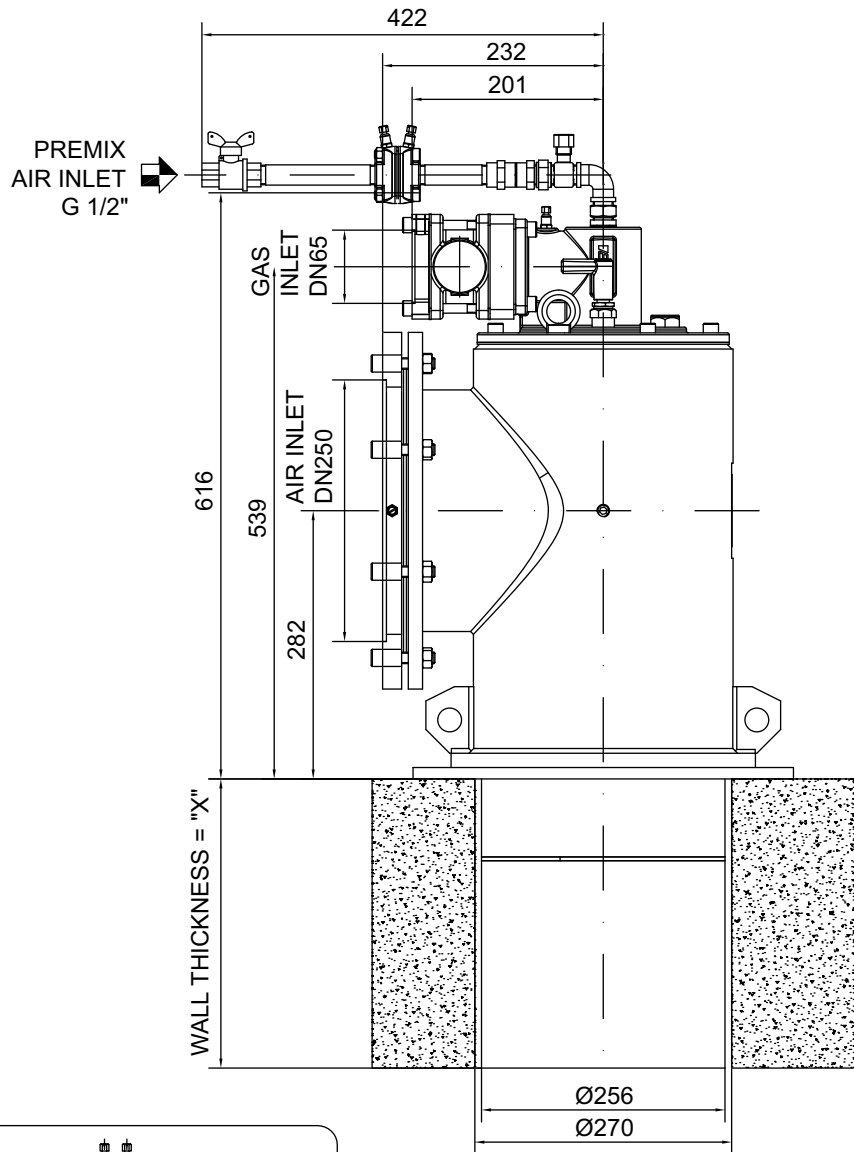

Gas orifice flowmeter (included)
Assembly by customer

- NOTES:
- (a) Suitable on customer request
 - (b) by customer

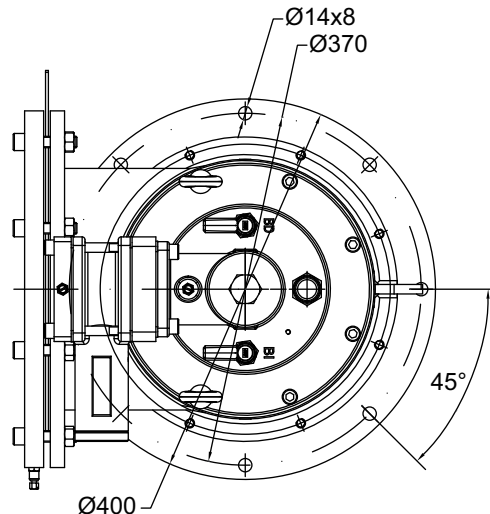

EMB-10 CH4 OVERALL DIMENSIONS

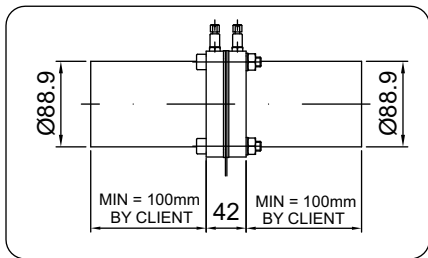
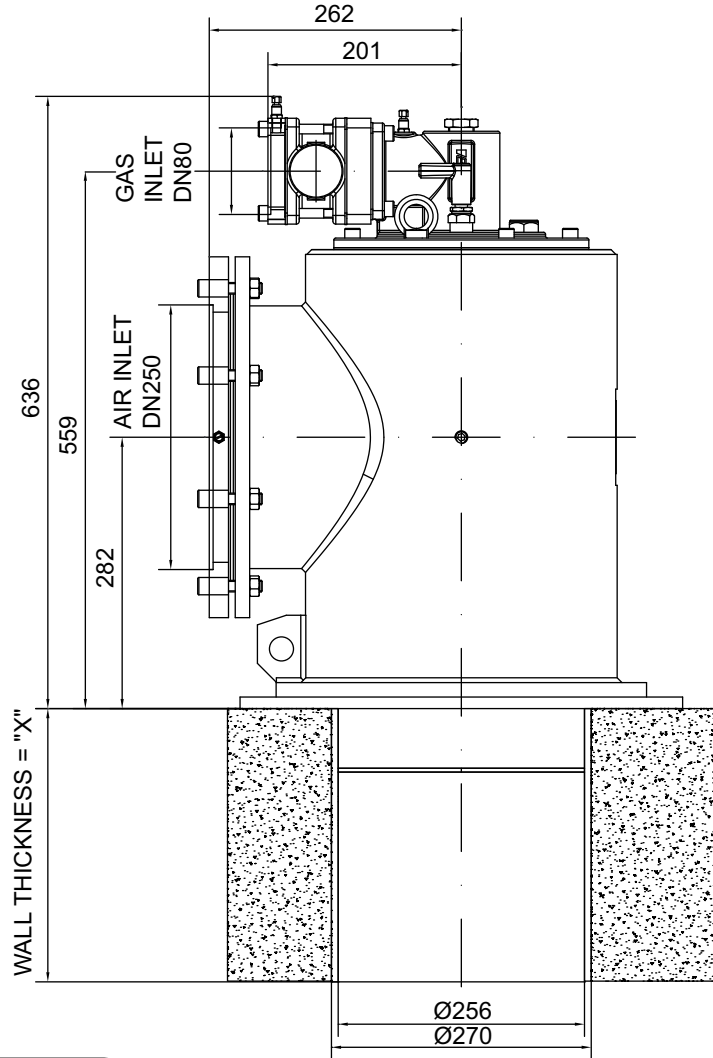

Gas orifice flowmeter (included)
Assembly by customer

NOTES:
(a) Suitable on customer request
(b) by customer

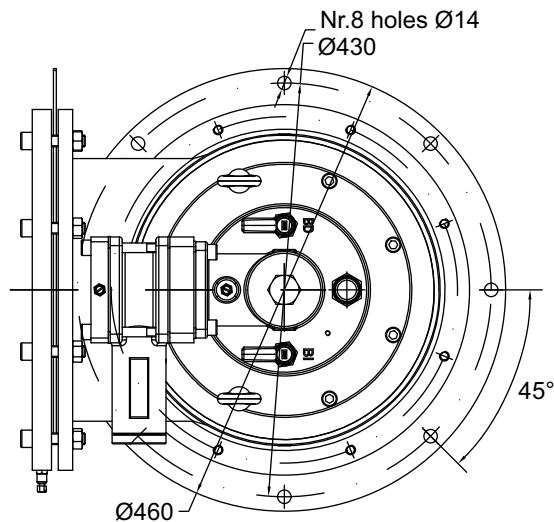

D3400125

EMB-10 GPL OVERALL DIMENSIONS

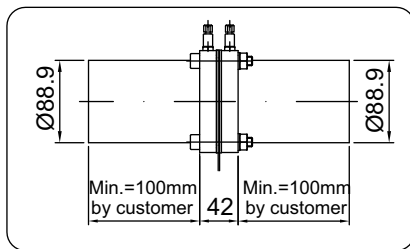
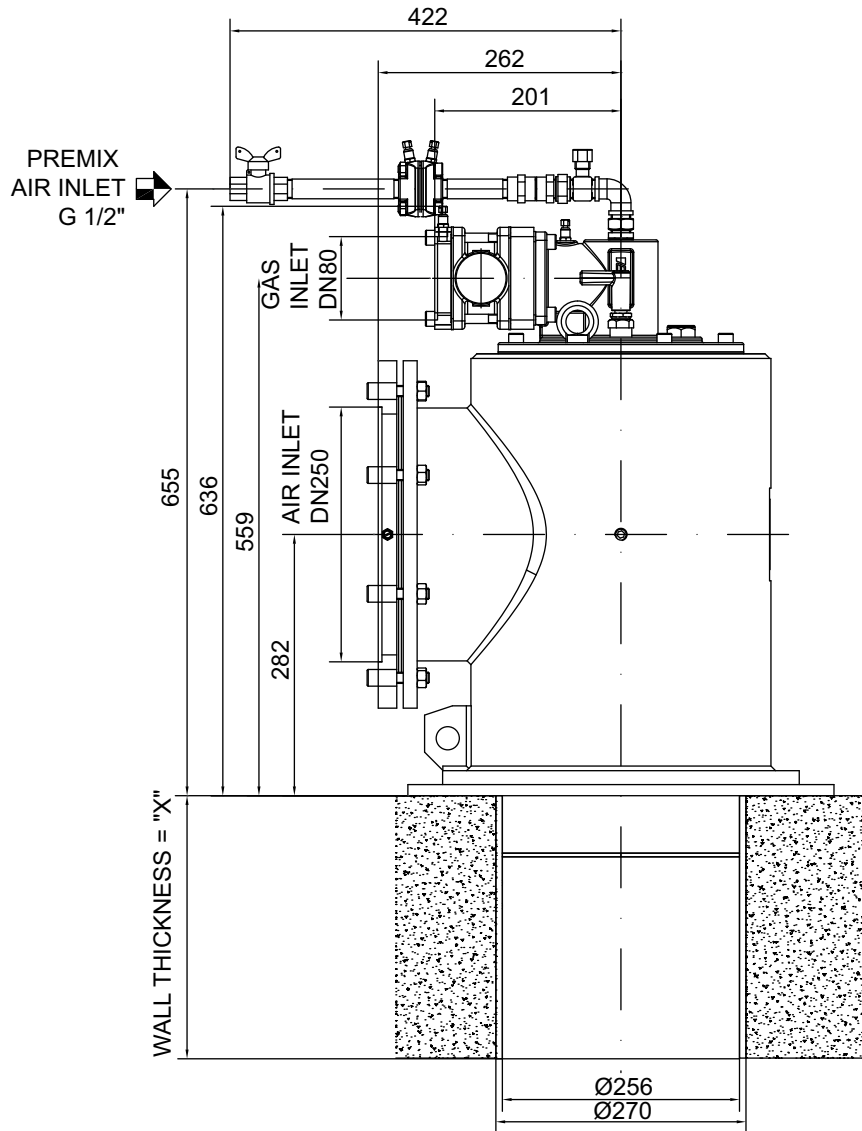

Gas orifice flowmeter (included)
Assembly by customer

- NOTES:**
(a) Suitable on customer request
(b) by customer

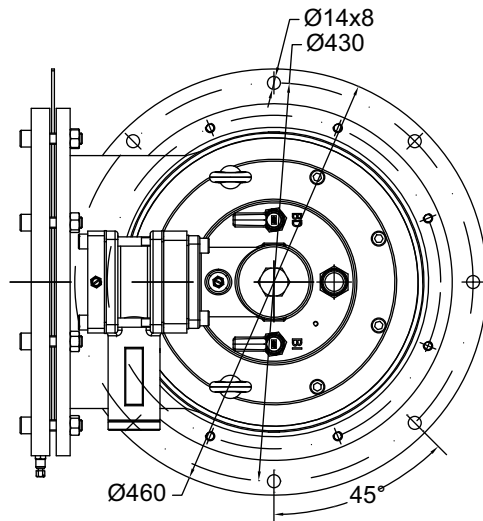

D3400127

EMB-6-BH OVERALL DIMENSIONS

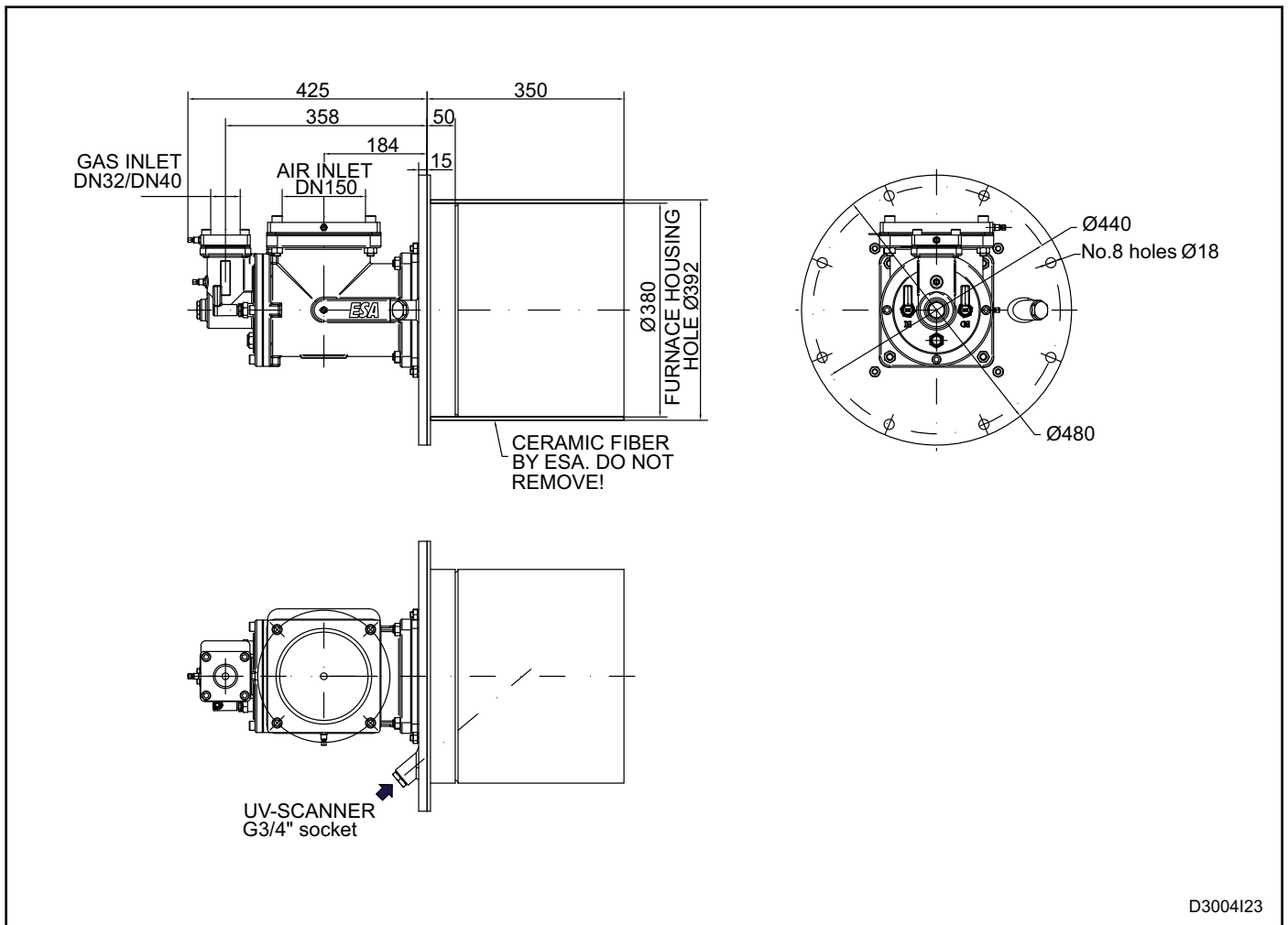

ORDERING CODE FOR COMPLETE BURNER

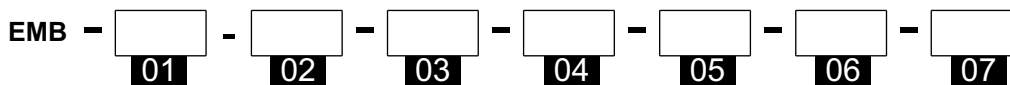

Model		01
EMB-0	0	
EMB-1	1	
EMB-2	2	
... (see capacity table)	

Gas adjuster		02
With gas adjuster	GA*	
Without gas adjuster	F	

Fuel		03
Natural gas	CH4	
LPG	GPL	
Poor gas (1)	GP	

04 Flame length	
Short flame (2)	FC*
Long flame (3)	FL (5)

05 Ignition and detection	
Ign. + det. Electrode	E*
Mono electrode	M
Pilot burner (4)	P

06 "X" flanged tube length	
Indicate the length in mm (see overall dimensions)	...

07 Type of flanging	
According to ESA drawing	E*
According to Client's drawing	C

The codes marked with an asterisk (*) identify the standards.

Notes:

- 1 Particular performance according to gas characteristics
- 2 Standard version for free flame applications
- 3 Version for applications with burner placed in open tube. Available up to version 4.
- 4 Available in the 3,4,5 and 6 models (see "ignition and detection" paragraph).
- 5 In open radiant tube applications.