

Operating instructions
Solenoid valve VGP



Translation from the German
© 2008–2011 Elster GmbH

Contents

Solenoid valve VGP 1

Contents 1

Safety..... 1

Checking the usage..... 2

Intended use 2

Type code..... 2

Part designations..... 2

Type label..... 2

Installation 2

Wiring 3

Tightness test..... 3

Replacing the actuator 4

VGP 10-15..... 4

VGP 20-25..... 4

Maintenance..... 4

VGP 10-15..... 4

VGP 20-25..... 5

Assistance in the event of malfunction 6

Technical data..... 7

Service life 7

Declaration of conformity 8

Approval for Australia 8

Approval for Russia 8

Contact 8

Safety

Please read and keep in a safe place



Please read through these instructions carefully before installing or operating. Following the installation, pass the instructions on to the operator. This unit must be installed and commissioned in accordance with the regulations in force. These instructions can also be found at www.docuthek.com.

Explanation of symbols

- , **1**, **2**, **3**... = Action
- > = Instruction

Liability

We will not be held liable for damages resulting from non-observance of the instructions and non-compliant use.

Safety instructions

Information that is relevant for safety is indicated in the instructions as follows:

⚠ DANGER

Indicates potentially fatal situations.

⚠ WARNING

Indicates possible danger to life and limb.

! CAUTION

Indicates possible material damage.

All interventions may only be carried out by qualified gas technicians. Electrical interventions may only be carried out by qualified electricians.

Conversion, spare parts

All technical changes are prohibited. Only use OEM spare parts.

Transport

On receipt of the product, check that the delivery is complete (see Part designations). Report any transport damage immediately.

Storage

Store the product in a dry place. Ambient temperature: see Technical data.

Checking the usage

Intended use

VGP

Gas solenoid valve for safeguarding gas or air on various appliances.

This function is only guaranteed when used within the specified limits – see page 7 (Technical data).

Any other use is considered as non-compliant.

Type code

Code	Description
VGP	Gas solenoid valve
10–25	Nominal diameter
R	Rp internal thread
01	$p_{e \text{ max.}}$ 150 mbar
02	$p_{e \text{ max.}}$ 200 mbar
Q	Mains voltage 120 V AC, 50/60 Hz
W	Mains voltage 230 V AC, 50/60 Hz
5	Connection via rectifier adapter without standard socket
6	Connection via rectifier adapter and standard socket

Part designations

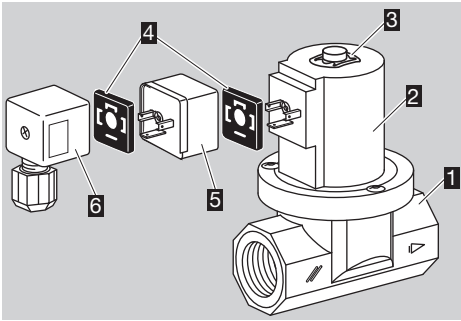

- 1** Housing
- 2** Actuator
- 3** Quick fastener
- 4** Seals
- 5** Rectifier adapter
- 6** Socket

Type label

Rated voltage, electrical power consumption, installation position, max. inlet pressure $p_{e \text{ max.}}$, ambient temperature, enclosure and medium: see type label.

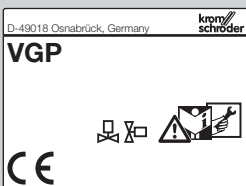

Installation

! CAUTION

Please observe the following to ensure that the VGP is not damaged during installation and operation:

- Do not clamp the unit in a vice. Only secure the flange by holding the octagon with a suitable spanner. Risk of external leakage.
 - Continuous operation at high temperatures accelerates the ageing of elastomer materials.
 - Do not install or store the unit in the open air.
 - Check max. ambient temperature – see type label.
 - Check max. inlet pressure – see type label.
- ▷ Installation position: black solenoid actuator in the vertical upright position or tilted up to the horizontal, not upside down.

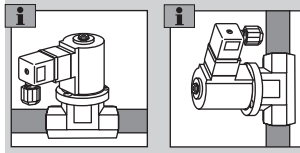

- ▷ The housing must not be in contact with masonry. Minimum clearance 20 mm.

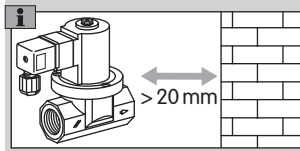

- ▷ Sealing material and dirt, e.g. thread cuttings, must not be allowed to get into the valve housing.
- ▷ Install a filter upstream of every system.
- ▷ Use approved sealing material only.
- ▷ Use a suitable spanner.

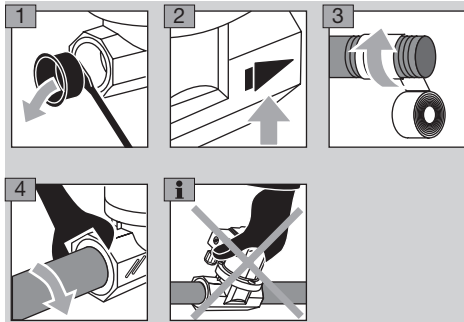

Wiring

WARNING

Electric shocks can be fatal! Before working on possible live components, ensure the unit is disconnected from the power supply.

- ▷ The solenoid actuator heats up during operation depending on ambient temperature and voltage.



- ▷ The rectifier adapter must be installed.
 - ▷ Use temperature-resistant cable (> 80°C).
- 1** Disconnect the system from the electrical power supply.
 - 2** Shut off the gas supply.
- ▷ Wiring to EN 60204-1.
 - ▷ The actuator can be rotated.

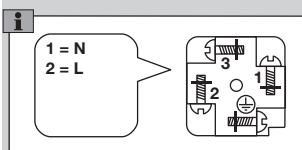
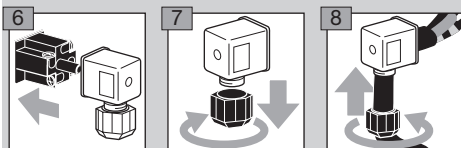
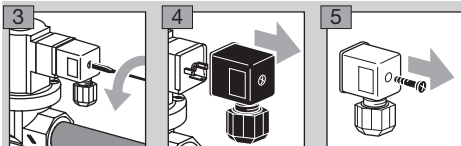

- ▷ Plug insert can be rotated in 90° steps.

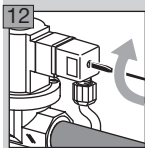
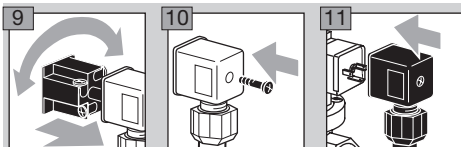

Tightness test

CAUTION

Please observe the following to ensure that the VGP is not damaged during the tightness test:

- Check max. inlet pressure – see type label.
- Test pressure $\leq 1.5 \times$ max. inlet pressure.

- 1** Close the solenoid valve.
- 2** To be able to check the tightness, shut off the downstream pipeline as close as possible to the valve.

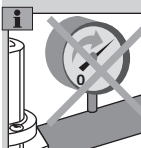
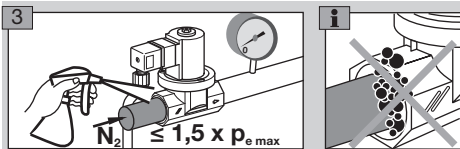

- 4** Open the solenoid valve.

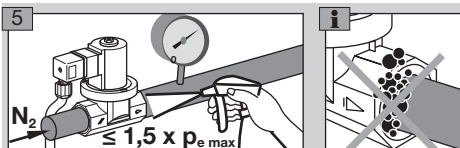

- 6** Tightness OK: the unit is ready for operation.
 - 7** Open the pipeline again and release the gas supply.
- ▷ VGP leaking: dismantle the unit and return it to the manufacturer.

Replacing the actuator

- ▷ We recommend replacing the entire actuator set when replacing the actuator.
- ▷ Actuator set VGP 10-15 comprises the actuator, 1 x O-ring, 1 x seal and 1 x quick fastener.
- ▷ Actuator set VGP 20-25 comprises the actuator and 2 x O-rings.
- ▷ The actuator set is available separately as a spare part.

VGP

- 1 Disconnect the system from the electrical power supply.
- 2 Shut off the gas supply.

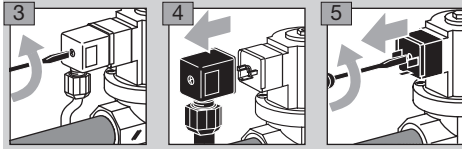

VGP 10-15

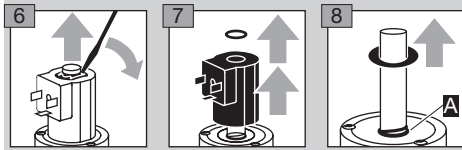

- ▷ Do not remove the grounding spring **A**.

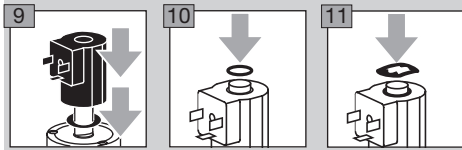

VGP 20-25

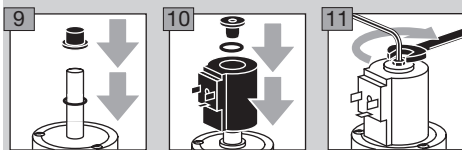
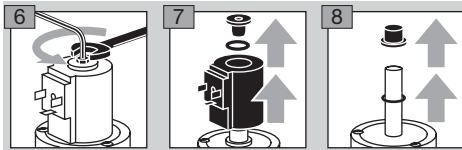

VGP

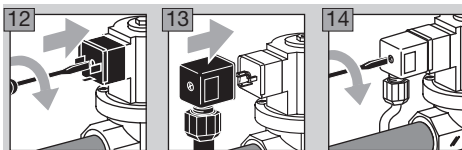

- 14 The unit is ready for operation.

- 15 Shut off the gas supply.

Maintenance

- ▷ In order to ensure smooth operation: check the tightness and function of the VGP every year, or every six months if operated with biologically produced methane.

Checking tightness and function

- ▷ In order to determine whether the VGP is tight and closes securely, check the internal and external tightness, see page 3 (Tightness test).
- ▷ Check electrical installations in line with local regulations; pay particular attention to the PE wire, see page 3 (Wiring).
- ▷ We recommend replacing the entire seal set when servicing the solenoid valve.
- ▷ Seal set VGP 10-15 comprises the valve seal, 2 x O-rings, 1 x seal and 1 x quick fastener.
- ▷ Seal set VGP 20-25 comprises the valve seal and 3 x O-rings.
- ▷ The seal set is available separately as a spare part.

VGP

- 1 Disconnect the system from the electrical power supply.
- 2 Shut off the gas supply.

VGP 10-15

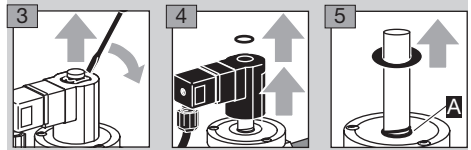

- ▷ Do not remove the grounding spring **A**.

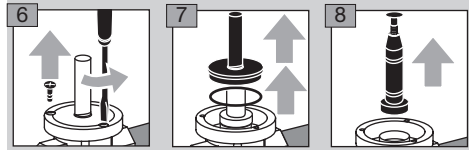

- ▷ Check closing spring for damage.
- ▷ Closing spring damaged: dismantle the unit and return it to the manufacturer.

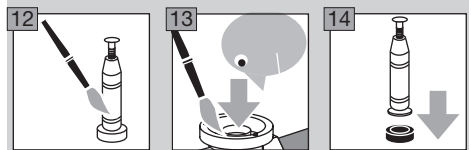
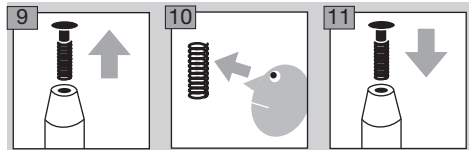

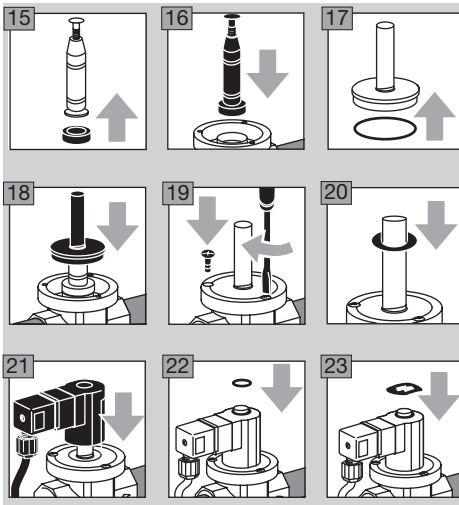

VGP 20-25

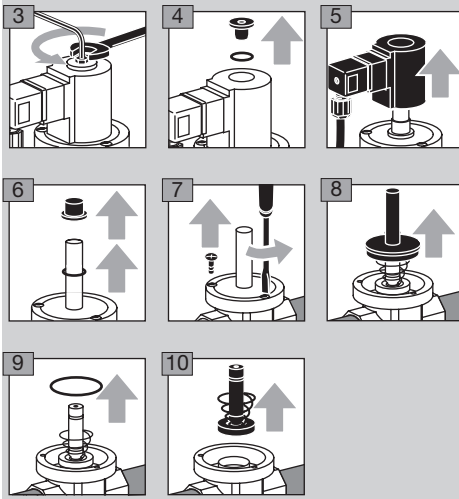

- ▷ Check closing spring for damage.
- ▷ Closing spring damaged: dismantle the unit and return it to the manufacturer.

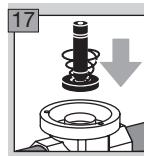
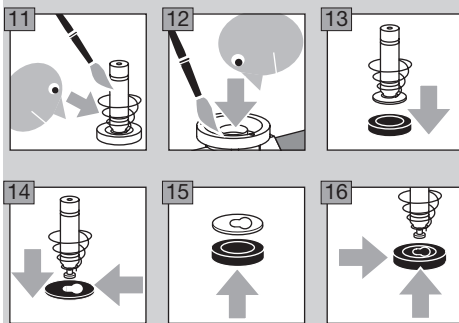

! CAUTION

Please observe the following to ensure that the VGP is not damaged during subsequent operation:
 – Install the closing spring in the correct position.
 Ensure that the catch of the closing spring is positioned in the opening of the valve disc.

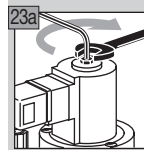
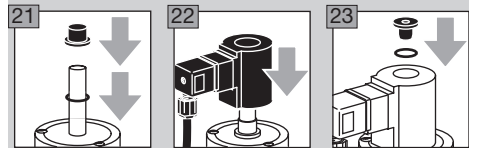
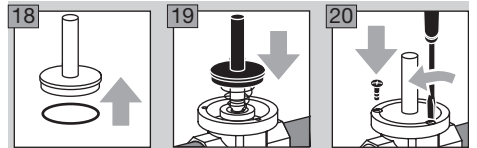
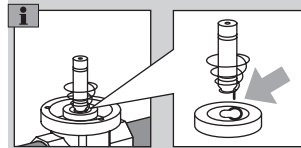

VGP

- 24** Close the solenoid valve.
- 25** To be able to check the tightness, shut off the downstream pipeline as close as possible to the valve.

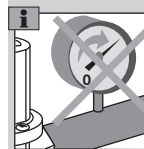
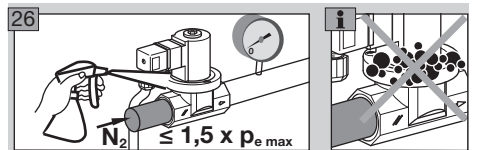

- 27** Tightness OK: the unit is ready for operation.

- 28 Open the pipeline again and release the gas supply.

Assistance in the event of malfunction

⚠ WARNING

Electric shocks can be fatal! Before working on possible live components, ensure the unit is disconnected from the power supply.

Fault-clearance must only be undertaken by authorized, trained personnel.

Unauthorized repairs or incorrect electrical connections can cause the solenoid valve to become defective. In this case, our warranty will be rendered void.

? **Fault**

! **Cause**

• **Remedy**

Possible faults and suggested solutions

? The solenoid valve does not open, there is no flow downstream of the solenoid valve.

! There is no power supply.

- Check wiring, see page 3 (Wiring).

! Rectifier adapter defective.

- Remove socket and rectifier adapter, see page 4 (Replacing the actuator), steps 1 to 5. Check the ohmic resistance of the rectifier adapter between contacts 1 and 2. Note the inscription on the rectifier adapter.

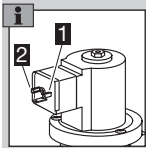

- No resistance, replace adapter.
- The rectifier adapter is available separately as a spare part.

! Actuator defective.

- Remove socket and rectifier adapter, see page 4 (Replacing the actuator), steps 1 to 5. Check the ohmic resistance of the actuator between contacts 1 (N) and 2 (L). Read off the contact assignment from the rectifier adapter.

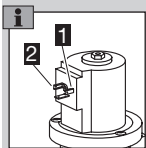

- No resistance, change actuator, see page 4 (Replacing the actuator).

- The actuator set is available separately as a spare part.

! Guiding elements bent. Incorrect handling when installing the unit.

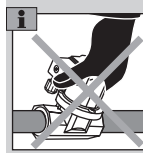

- Dismantle the unit and return it to the manufacturer.

? The solenoid valve does not close securely, the flow downstream of the solenoid valve does not stop.

! Valve seat is dirty.

- Clean the valve seat, see page 4 (Maintenance).

- Install a filter upstream of the solenoid valve.

! Valve seat is damaged.

- Dismantle the unit and return it to the manufacturer.

! Valve seal is damaged or hardened.

- Replace the valve seal, see page 4 (Maintenance).

! Guiding elements bent. Incorrect handling when installing the unit.

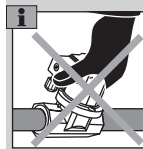

- Dismantle the unit and return it to the manufacturer.

Technical data

Gas types: natural gas, town gas, LPG (gaseous), biologically produced methane (max. 0.1 %-by-vol. H₂S) or clean air; other gases on request. The gas must be dry in all temperature conditions and must not contain condensate.

Opening time: 0.5 s.

Closing time: < 1 s.

Ambient temperature: -20 to +60°C.

Storage temperature: -20 to +40°C.

Safety valve:

Class A Group 2 pursuant to EN 161.

Mains voltage:

230 V AC, +10/-15%, 50/60 Hz,

120 V AC, +10/-15%, 50/60 Hz.

Electrical connection:

plug with socket to EN 175301-803.

Power consumption:

Type	120/230 V AC [W]
VGP 10	26
VGP 15	26
VGP 20	35
VGP 25	35

Enclosure: IP 54.

Duty cycle: 100%.

Power factor of the solenoid coil: $\cos \varphi = 1$.

Solenoid coil insulation: class F insulating material.

Switching frequency: any.

Valve housing: aluminium,

valve disc: Perbunan.

Internal thread: Rp to ISO 7-1.

Service life

The Pressure Equipment Directive (PED) and the Energy Performance of Buildings Directive (EPBD) demand regular checks on and maintenance of heating systems, in order to ensure a high level of use in the long term, a clean method of operation and safe function.

The service life on which the construction is based, hereinafter referred to simply as the "service life", is compiled from the relevant standards. You can find further explanations in the applicable rules and regulations and on the afecor website (www.afecor.org). This information on service life is based on using the product in accordance with these operating instructions.

The product must be serviced at regular intervals. Once the specified service life has been reached, the safety-related functions must be checked in accordance with the section entitled "Maintenance".

If the product passes the aforementioned function tests, you can continue to use it until the next scheduled maintenance operation. At this point, these tests must be repeated.

If the product fails one of the aforementioned tests, it must be replaced immediately.

This procedure applies to heating systems. For thermoprocessing equipment, observe national regulations.

Service life (based on date of manufacture) in accordance with EN 13611, EN 161 for VGP:

Type	Service life	
	Switching cycles	Time [years]
VGP 10 to 15	200,000	10
VGP 20 to 25	500,000	10

Long-term use in the upper ambient temperature range accelerates the ageing of the elastomer materials and reduces the service life (please contact manufacturer).

Declaration of conformity



We, the manufacturer, hereby declare that the product VGP, marked with product ID No. CE-0063BL1554, complies with the requirements of the listed Directives and Standards.

Directives:

- 2009/142/EC (90/396/EEC),
- 2006/95/EC,
- 2004/108/EC.

Standards:

- EN 13611,
- EN 161.

The relevant product corresponds to the type tested by the notified body 0063.

The production is subject to the surveillance procedure pursuant to DIN EN ISO 9001 according to annex II, paragraph 3 of Directive 2009/142/EC.

Elster GmbH

Scan of the Declaration of conformity (D, GB) – see www.docuthek.com

Approval for Australia



Australian Gas Association, Approval No.: 5567
www.aga.asn.au/product_directory

Approval for Russia



Certified by Gosstandart pursuant to GOST-TR.
Approved by Rostekhnadzor (RTN).

Contact

If you have any technical questions, please contact your local branch office/agent. The addresses are available on the Internet or from Elster GmbH.

We reserve the right to make technical modifications in the interests of progress.

elster
Kromschröder

Elster GmbH
Postfach 28 09, D-49018 Osnabrück
Strotheweg 1, D-49504 Lotte (Büren)

T +49 541 1214-0

F +49 541 1214-370

info@kromschroeder.com, www.kromschroeder.com