



OM

Measuring orifice

1/2" - 3"

OM

Contents

Description	2
Features	2
Functioning and application	3
Technical specifications	4
Flow calculation	5
Orifice selection	8
Ordering Information	9
Standards	9

Description

OM device is an orifice for measuring fluid flow through differential pressure meter. In combustion plants, this solution is very useful for measuring gas and air flow and set correctly combustion parameters.

Features

OM orifices are deliverable with threaded connection from ½" to 2". Size 2"½ and 3" must be mounted between two flanges.

Orifice diameter is available with a wide range so that passage can be properly chosen according to working conditions and a good measurement can be returned in any situation. If necessary, measuring plate can be replaced.

Body is made of aluminum alloy, measuring plate is made of stainless steel.

Sealings are made of NBR rubber for use with air and gas (1st, 2nd and 3rd families EN 437).

These devices can be provided with plugs or test points Ø9.

All components are designed to withstand any mechanical, chemical and thermal condition occurring during typical service.

OM devices are 100% tested and fully warranted.

Functioning and application

Flow measurement is based on the installation of a calibrated orifice inside the pipe. This orifice originates a pressure difference between upstream and downstream sections. Measuring this pressure difference, it is possible to estimate flow with formula or table in next pages. For good measurement, the pipe before and after the orifice has to be straight for a minimum length of 5xDN.

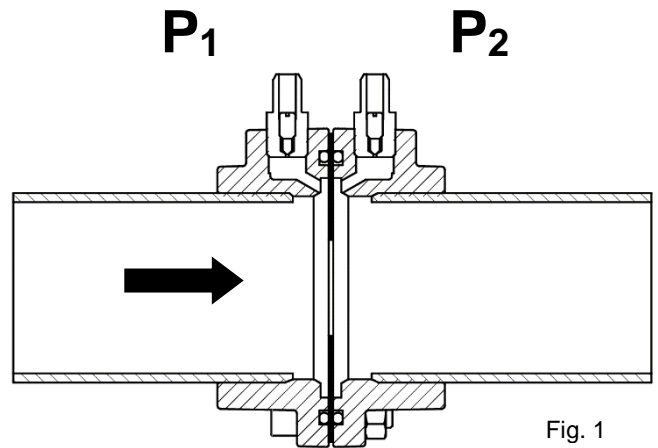

Fig. 1

This device is usually installed to measure gas and air flows in combustion plants, so that combustion regulation is easier. Fig. 2 shows an example of installation, in combination with other Elektrogas devices.

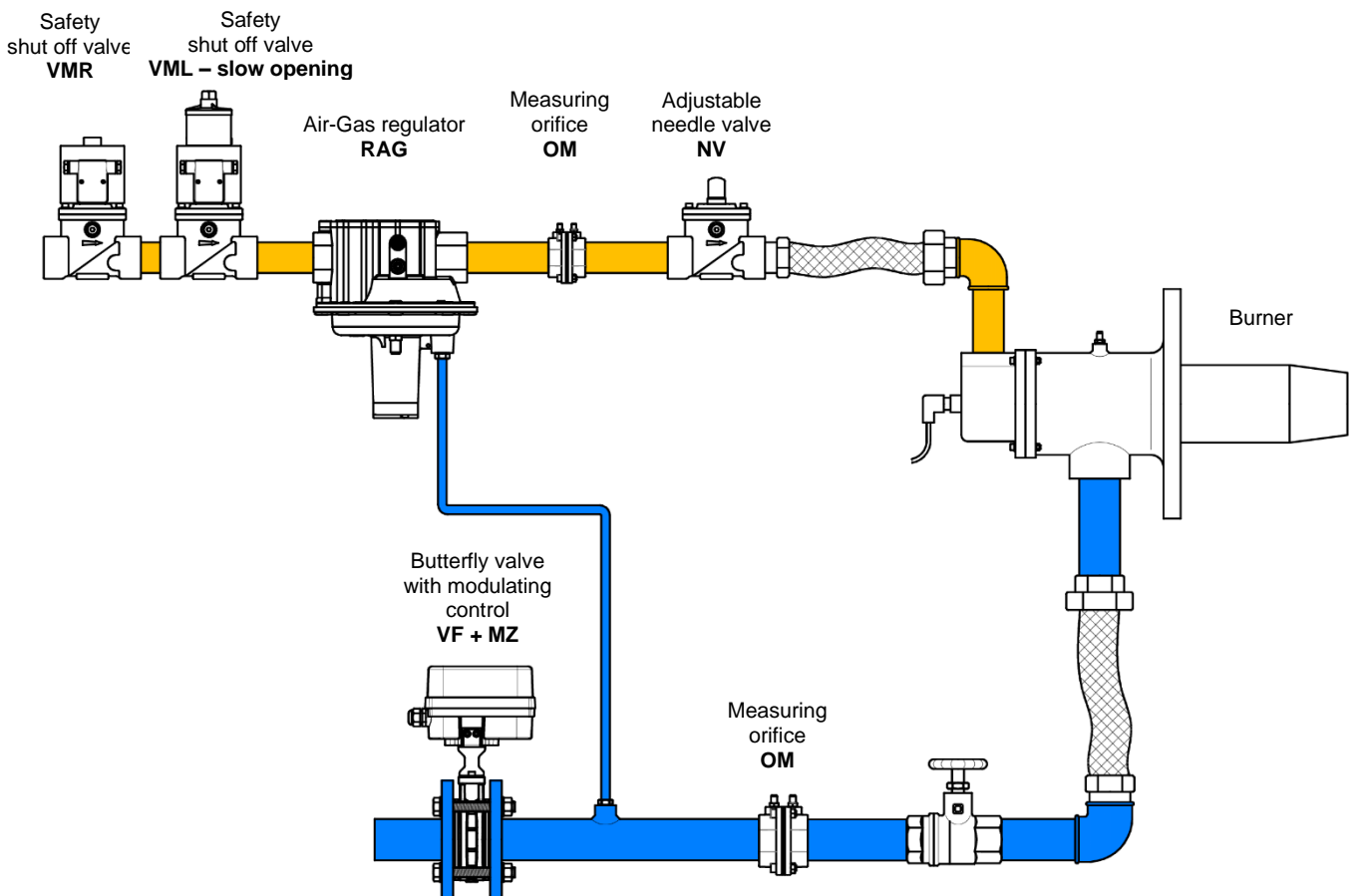

Fig. 2



WARNING

Location and mode of installation must be in compliance with local rules in force.

Technical specifications

Tab. 1

Main connections	Internal threaded ISO 7-1 Rp1/2 – Rp2 or ANSI-ASME B1.20 1/2"NPT – 2"NPT
	Between two flanges EN 1092 PN16 DN65 or DN80 or ANSI-ASA-ASME B16.5 class 150 2"½ or 3"
Test points connections	G1/8 (1/2"-1") - G1/4 (1"¼-3") ISO 228 or 1/8"NPT (1/2"-1") - 1/4" NPT (1"¼-3")
Max working pressure	500 mbar
Ambient temperature	-15°C / +60°C (+5°F to +140°F)
Materials in contact with gas	Aluminum alloy, Brass, Stainless steel, Plated steel, Anaerobic adhesive, Nitrile rubber (NBR)

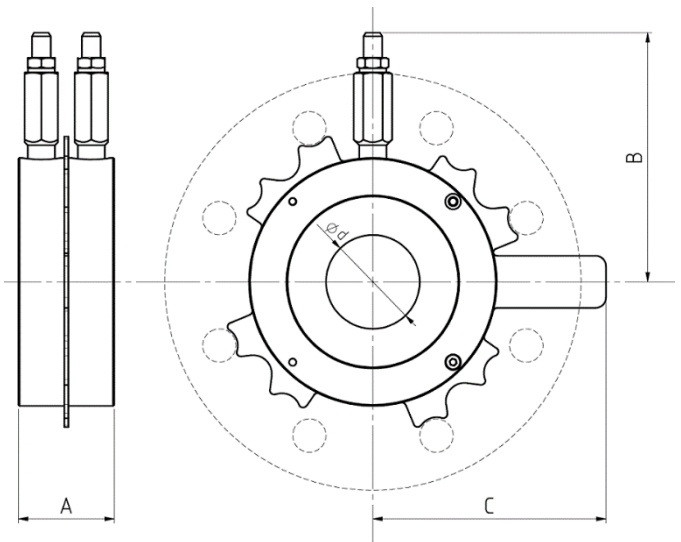
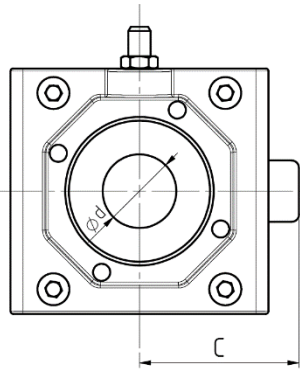
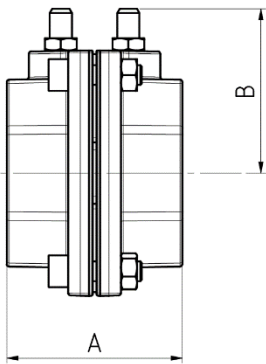

Models with threaded connection 1/2"-2"

Model between two flanges 2"½-3"

Tab. 2

Model	Connection	A (mm)	B (mm)	C (mm)	d min (mm)	d max (mm)	Weight (Kg)
OM1	1/2" internal threads	50	47	42	4	10	0,4
OM2	3/4" internal threads	50	47	42	4	14	0,4
OM3	1" internal threads	50	47	42	4	18	0,4
OM35	1"¼ internal threads	72	67	65	12	24	0,95
OM4	1"½ internal threads	72	67	65	12	24	0,95
OM6	2" internal threads	72	67	65	12	34	0,95
OM78	2"½ - 3" between flanges	46	120	112	34	50	1,05

Flow calculation

Flow through orifice can be estimated with:

Q_s = gas flow rate in standard condition (sm^3/h)

(standard condition $15^\circ C$ 1,013bar, dry - $1 sm^3/h = 0.947 Nm^3/h$)

P_1 = gas pressure before the orifice (mbar – value relative to atmosphere)

P_2 = gas pressure after the orifice (mbar – value relative to atmosphere)

d = orifice diameter (mm)

D = internal pipe diameter (mm)

ρ_s = density at standard condition (Kg/sm^3)

T = temperature at working conditions ($^\circ C$)

$$\beta = \frac{d}{D}$$

$$Dp = P_1 - P_2$$

$$Q_s = \frac{0.01285}{\sqrt{1 - \beta^4}} d^2 \sqrt{\frac{Dp * (P_1 + 1013.25)}{\rho_s * (T + 273.15)}}$$

Size	Typical internal pipe diameter D (mm)	Gas type	Typical density at standard condition ρ [Kg/m^3]
1/2"	16	Natural gas	0,80
3/4"	22	LPG	2,08
1"	28	Air	1,23
1 1/4"	35		
1 1/2"	41		
2"	56		
2 1/2"	67		
3"	80		

Example:

Flow of

-natural gas at $30^\circ C$

-through orifice 28 mm in pipe 2"

-inlet pressure 50mbar and outlet pressure 45 mbar

$$\beta = \frac{28}{56} = 0.5$$

$$Dp = 50 - 45 = 5 \text{ mbar}$$

$$Q_s = \frac{0.01285}{\sqrt{1 - 0.5^4}} 28^2 \sqrt{\frac{5 * (50 + 1013.25)}{0.80 * (30 + 273.15)}} = 48.7 \text{ smc/h}$$

In table below some **values of flow rates (sm³/h)** with inlet pressure 50mbar and temperature 15°C for fast checking:

Pipe	Orifice bore (mm)	Item	<i>Air 1,23 Kg/sm³</i>				<i>Natural Gas 0,8 Kg/sm³</i>			
			<i>Dp (mbar)</i>				<i>Dp (mbar)</i>			
			1	2	5	10	1	2	5	10
1/2"	4	OM1.4	0,36	0,50	0,80	1,13	0,44	0,63	0,99	1,40
	8	OM1.8	1,47	2,08	3,29	4,65	1,82	2,58	4,08	5,77
	12	OM1.12	3,88	5,48	8,67	12,26	4,81	6,80	10,75	15,20
3/4"	8	OM2.8	1,44	2,03	3,21	4,54	1,78	2,52	3,98	5,63
	12	OM2.12	3,36	4,75	7,51	10,62	4,16	5,89	9,31	13,16
	16	OM2.16	6,71	9,49	15,01	21,23	8,32	11,77	18,61	26,33
1"	10	OM3.10	2,24	3,17	5,02	7,10	2,78	3,93	6,22	8,80
	14	OM3.14	4,51	6,37	10,07	14,25	5,59	7,90	12,49	17,67
	18	OM3.18	7,92	11,20	17,71	25,04	9,82	13,89	21,96	31,05
1¼"	12	OM35.12	3,2	4,6	7,2	10,2	4,0	5,7	8,9	12,7
	20	OM35.20	9,4	13,3	21,1	29,8	11,7	16,5	26,1	36,9
	28	OM35.28	22,7	32,1	50,8	71,8	28,2	39,8	63,0	89,0
1½"	12	OM4.12	3,2	4,5	7,2	10,2	4,0	5,6	8,9	12,6
	20	OM4.20	9,2	13,0	20,5	29,0	11,4	16,1	25,4	35,9
	28	OM4.28	19,7	27,9	44,1	62,4	24,5	34,6	54,7	77,3
2"	16	OM6.16	5,7	8,1	12,8	18,1	7,1	10,0	15,9	22,4
	24	OM6.24	13,0	18,4	29,2	41,2	16,2	22,9	36,2	51,1
	34	OM6.34	27,7	39,1	61,9	87,5	34,3	48,5	76,7	108,5
2½"	34	OM78.34	26,6	37,7	59,5	84,2	33,0	46,7	73,8	104,4
	42	OM78.42	42,7	60,4	95,5	135,0	52,9	74,9	118,4	167,4
	50	OM78.50	67,0	94,7	149,8	211,8	83,1	117,5	185,7	262,7
3"	34	OM78.34	26,2	37,0	58,5	82,7	32,4	45,9	72,5	102,6
	42	OM78.42	40,8	57,8	91,3	129,2	50,6	71,6	113,2	160,1
	50	OM78.50	60,4	85,5	135,2	191,1	74,9	106,0	167,6	237,0

In table below some **values of flow rates (SCFH)** with inlet pressure 20"wc and temperature 60°F for fast checking:

Pipe	Orifice bore (mm)	Item	Air 1,23 Kg/sm ³				Natural Gas 0,8 Kg/sm ³			
			Dp ("wc)				Dp ("wc)			
			0.4	0.8	2.0	4.0	0.4	0.8	2.0	4.0
1/2"	4	OM1.4	12,6	17,8	28,1	39,8	15,6	22,1	34,9	49,4
	8	OM1.8	51,9	73,4	116,0	164,1	64,3	91,0	143,9	203,5
	12	OM1.12	136,7	193,4	305,8	432,4	169,6	239,8	379,1	536,2
3/4"	8	OM2.8	50,7	71,7	113,4	160,3	62,9	88,9	140,6	198,8
	12	OM2.12	118,4	167,5	264,8	374,5	146,8	207,7	328,3	464,3
	16	OM2.16	236,8	334,9	529,6	748,9	293,7	415,3	656,6	928,6
1"	10	OM3.10	79,2	111,9	177,0	250,3	98,2	138,8	219,5	310,4
	14	OM3.14	158,9	224,8	355,4	502,6	197,1	278,7	440,6	623,2
	18	OM3.18	279,3	395,1	624,6	883,4	346,4	489,9	774,5	1.095,3
1"¼	12	OM35.12	114	161	255	360	141	200	316	446
	20	OM35.20	332	470	743	1.051	412	583	921	1.303
	28	OM35.28	801	1.133	1.791	2.533	993	1.405	2.221	3.141
1"½	12	OM4.12	113	160	254	359	141	199	315	445
	20	OM4.20	323	457	723	1.022	401	567	896	1.268
	28	OM4.28	696	984	1.556	2.200	863	1.220	1.929	2.728
2"	16	OM6.16	202	285	451	638	250	354	559	791
	24	OM6.24	460	651	1.029	1.455	570	807	1.276	1.804
	34	OM6.34	976	1.381	2.183	3.087	1.211	1.712	2.707	3.828
2"½	34	OM78.34	939	1.328	2.100	2.970	1.165	1.647	2.604	3.683
	42	OM78.42	1.506	2.130	3.368	4.763	1.867	2.641	4.176	5.906
	50	OM78.50	2.363	3.342	5.284	7.473	2.930	4.144	6.552	9.266
3"	34	OM78.34	923	1.305	2.063	2.918	1.144	1.618	2.558	3.618
	42	OM78.42	1.441	2.038	3.222	4.556	1.786	2.526	3.995	5.649
	50	OM78.50	2.132	3.015	4.768	6.743	2.644	3.739	5.912	8.360

An example to show how flow varies with different inlet pressure:

Device: OM3.10

Fluid: Air ($1,23 \text{ Kg/sm}^3$) at 15°C

$D_p = 2 \text{ mbar} / 0.8''\text{wc}$

Inlet pressure P1	30 mbar 12''wc	50 mbar 20''wc	100 mbar 40''wc	200mbar 3psig	500mbar 7psig
Flow (sm ³ /h)	3.14	3.17	3.25	3.39	3.79
$\frac{Q_{P1}}{Q_{P1 50mbar}} \%$	99%	100%	102.5%	107%	120%

Example above shows that values given in tables are very useful for low pressure, with pressure of 200mbar / 3psig or higher the use of formula is advisable.

Orifice selection

The selection starts from:

- fluid type
- maximum flow
- temperature
- pressure at inlet and maximum pressure loss
- pipe where orifice will be inserted

Orifice passage can be estimated with:

$$d \sim 6.36 \sqrt{Q_s \sqrt{\frac{\rho_s}{D_{pmax}}}}$$

with this result we can choose the orifice immediately higher between those available.

For a good measurement, the ratio $\beta = \frac{d}{D}$ has to be $0.1 \leq \beta \leq 0.75$. If this condition is not true, it is necessary to take a greater pressure drop or change the pipe.

If β is correct, it is possible to calculate the pressure drop with that orifice and the formula:

$$Dp = \frac{Qs^2 (1 - \beta^4) 10^4 \rho_s (T + 273.15)}{1.65 * d^4 (P_1 + 1013.25)}$$

Example:

Orifice selection for:

air at 50°C (ρ_s 1,23 Kg/sm³)

60 sm³/h at 40mbar

max Dp 8 mbar

pipe 2"

$$d \sim 6.36 \sqrt{60 \sqrt{\frac{1.25}{8}}} = 30.85 \text{ mm}$$

The model OM6.34 is chosen and pressure drop will be approximately:

$$\beta = \frac{34}{56} = 0.607 \quad \text{OK}$$

$$Dp = \frac{60^2 (1-0.607^4) 10^4 * 1.25 (50+273.15)}{1.65 * 34^4 (40+1013.25)} = 5.3 \text{ mbar}$$

Ordering Information

Tab. 4

	OM	2	P	10
Device type				
OM measuring orifice				
Connections size				
1 Rp1/2	1N	1/2"NPT		
2 Rp3/4	2N	3/4"NPT		
3 Rp1	3N	1"NPT		
35 Rp1¼	35N	1¼"NPT		
4 Rp1½	4N	1½"NPT		
6 Rp2	6N	2"NPT		
78 DN65-DN80 wafer	78N	2½"-3"ANSI wafer		
Pressure points				
. plugs				
P fittings Ø 9				

Orifice diameter d (mm)

Connection	Available orifices (mm)							
	4	6	8	10	12	14	16	18
½" - 1"								
1¼"-2"	12	16	20	24	28	34		
2½" - 3"	28	34	38	42	46	50		

Example: OM2P10: orifice with connection Rp3/4, passage Ø10, with fittings Ø9.

Tab. 7

DM**3****.****12****Device type****DM** Spare plate for measuring orifice**For device with connections:****3** ½"-3/4"-1"**6** 1"¼-1"½-2"**78** 2½"-3"**Orifice diameter d (mm)***Example* : **DM3.12**: plate for orifice with connections ½" or 3/4" or 1" with passage Ø12**Standards**

These devices are designed according to European standard EN 13611.

Quality Management System of manufacturer is certified according to UNI EN ISO 9001 and the monitoring is carried out by the notified body:

Kiwa Cermet Italia Spa

Reg.-n° 11989-A

**Elektrogas®** is a brand name of**ELETTROMECCANICA DELTA S.p.A.** - Via Trieste, 132 - 31030 Arcade (TV) - Italy - Tel +39 0422 874068**www.delta-elektrogas.com**info@delta-elektrogas.com

ELETTROMECCANICA DELTA S.p.A. reserves the right to update or make any technical changes without prior notice.

Copyright © 2023 All rights reserved.