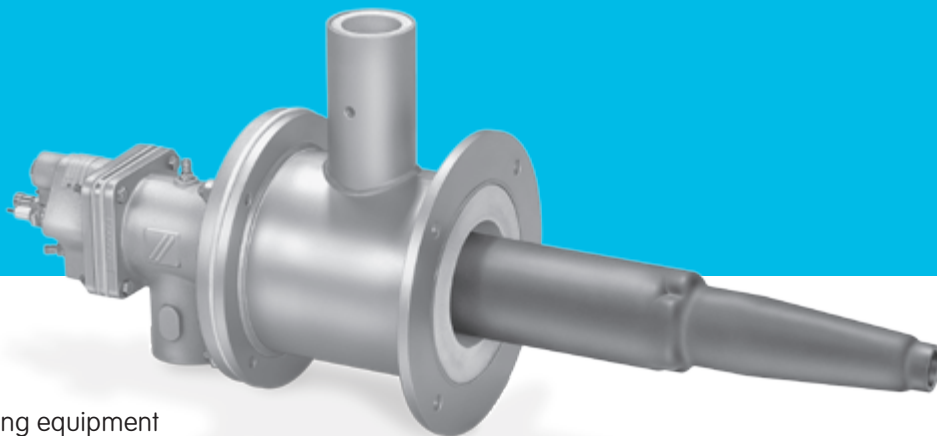


Burner with integrated recuperator BICR

Technical Information · GB
7.2.4 Edition 10.11



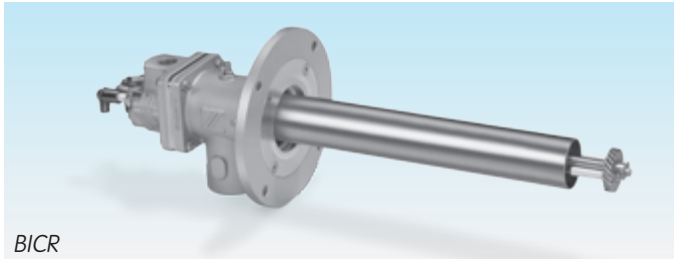
krom
schroder

- For direct and indirect heating equipment
- Economical, energy-saving operation by virtue of internal air preheating
- Great flexibility due to its maintenance-friendly modular design
- Lightweight construction for minimum weight
- High flue gas outlet velocity ensures uniform temperature distribution
- Low pollution combustion
- Direct ignition and monitoring
- Low cost gas/air control is possible
- High usage due to a ceramic pipe heat exchanger
- Low gas and air connection pressures
- As a result of its compact design it is ideal for replacing the heating elements in radiant tubes which were originally electrically heated

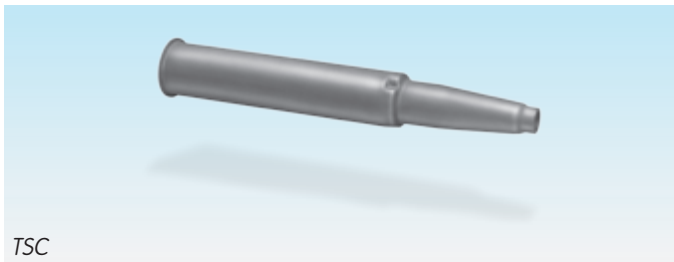


Table of contents

Burner with integrated recuperator BICR	1	5.1 Indirect heating	24
Table of contents	2	5.2 Direct heating	26
1 Application	3	5.3 Installation	27
1.1 Indirect heating	3	5.4 Recommended ignition transformer	28
1.2 Direct heating	3	5.5 Nozzle-mixing burners	28
1.3 Example applications	4	5.6 Flame control	28
1.3.1 BICR in a P radiant tube	6	5.7 Cooling the recuperative burner	29
1.3.2 BICR in a single-ended radiant tube	7	5.8 Emissions	30
1.3.3 BICR in a single-ended radiant tube with burner control unit	8	5.9 Gas line connection	30
1.3.4 BICR in a single-ended radiant tube with automatic burner control units	9	5.9.1 System with or without pneumatic air/gas ratio control system	31
1.3.5 Single-stage-controlled BICR in a single-ended radiant tube with pneumatic link to the burner control unit	10	5.9.2 Systems without a pneumatic link	31
1.3.6 Single-stage-controlled BICR in a single-ended radiant tube with pneumatic link to the automatic burner control unit	11	6 Technical data	32
1.3.7 BICR for direct heating systems	12	6.1 Dimensions	33
1.3.8 BICR for direct heating systems with air deficiency cut-out	13	6.1.1 BICR + TSC	33
2 Mechanical construction	14	6.1.2 EGH	34
2.1 Burners BICR	14	7 Maintenance cycles	35
2.2 Combustion chamber / Heat exchanger TSC	14	8 Accessories	36
2.3 Exhaust-gas housing EGH	14	Feedback	38
2.4 Rotational adapter flange	15	Contact	38
3 Function	16		
3.1 Indirect heating	16		
3.2 Direct heating	16		
4 Selection	17		
4.1 Burners BICR	17		
4.2 Exhaust-gas housing EGH	18		
4.3 Ceramic tube set TSC	19		
4.4 Burner design	20		
4.5 Calculating the burner length	21		
5 Project planning information	24		



BICR



TSC



EGH

Modular construction consisting of the burner BICR, the ceramic pipe heat exchanger module TSC and the exhaust-gas housing EGH with integral insulation

1 Application

The burners with integrated recuperator BICR are for use on heating either direct or indirect furnace systems.

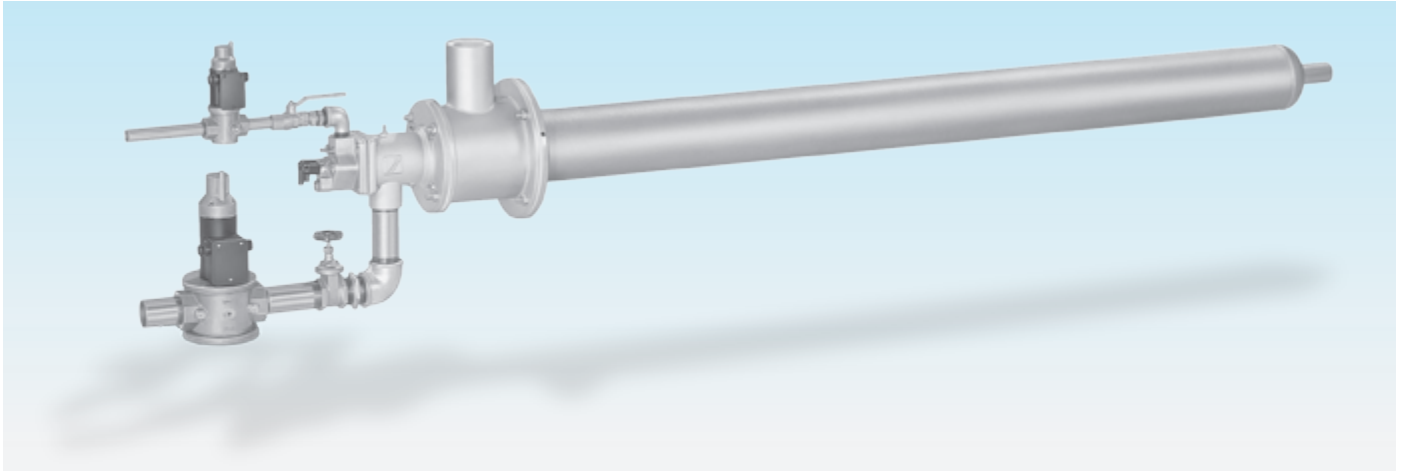
1.1 Indirect heating

BICR recuperative burners in conjunction with radiant tubes are used as indirect heating equipment where the combustion gases must be separated from the product or a certain furnace atmosphere must be achieved.

1.2 Direct heating

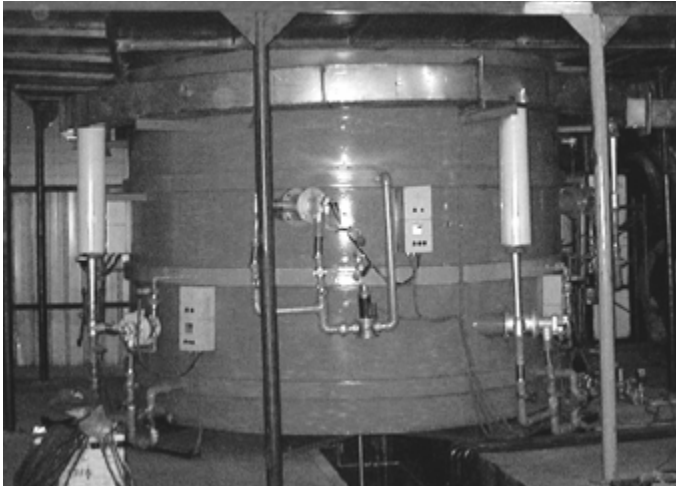
In conjunction with an inductor to return the flue gas, the burner is used to save energy in a direct heating system.

Applications include industrial furnaces and firing systems in the iron and steel industry and in the non-ferrous metals industry.



1.3 Example applications

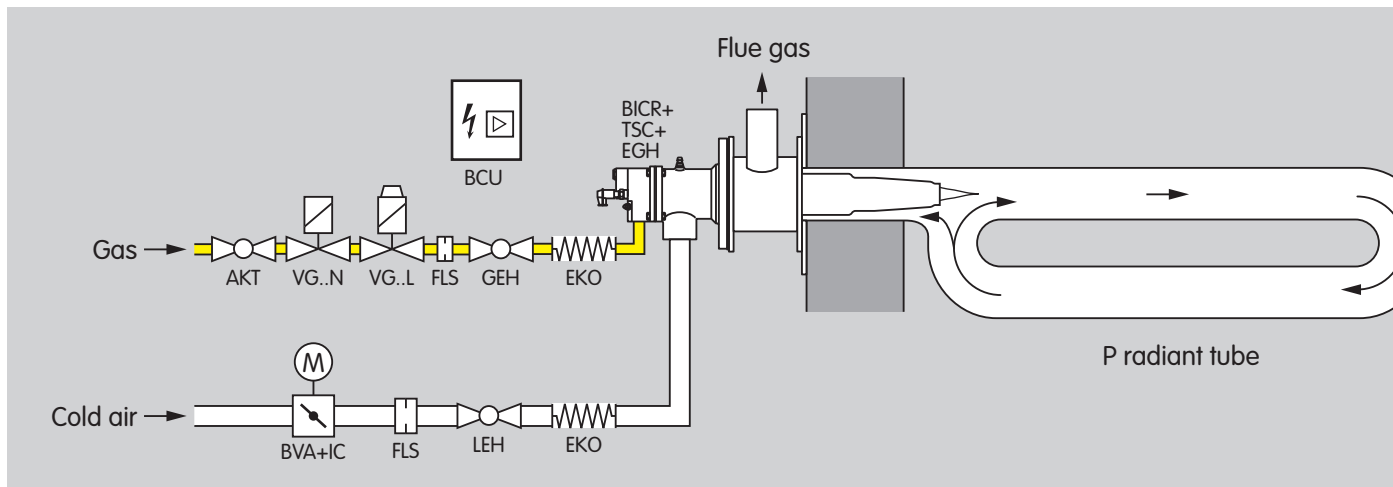
Indirect heating in a single-ended radiant tube



Direct heating of a bell furnace for annealing. Flue gases are recycled via the inductor.



Direct heating of a roller hearth furnace.



1.3.1 BICR in a P radiant tube

Example application for indirect heating.

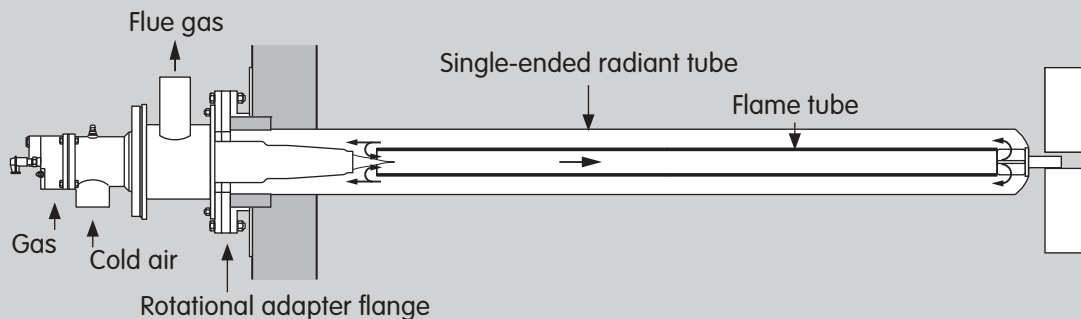
The high outlet velocity of the combustion gases generates a pressure at the outlet of the ceramic burner tube, resulting in the recirculation of the flue gases. This leads to the following:

- A reduction in NO_x emissions,
- A uniform radiant tube temperature.

The hot flue gases are fed through the ceramic heat exchanger, heating the additional cold combustion air supply. The maximum achievable air preheat temperature is approx. 400°C.

Legend

- BCU = Burner control unit
- VG..L = Solenoid valve for gas, slow-opening
- GEH* = Flow adjusting cock for gas
- EKO = Stainless steel bellows unit
- FLS* = Measuring orifice
- BICR = Burner with integrated recuperator
- TSC = Ceramic tube
- EGH = Exhaust-gas housing
- BVA = Butterfly valve for air
- IC = Actuator
- LEH = Flow adjusting cock for air
- * Required in the gas circuit on BICR 65/50 only



1.3.2 BICR in a single-ended radiant tube

Example application for indirect heating.

The high outlet velocity of the combustion gases generates a pressure at the outlet from the ceramic burner tube resulting in the recirculation of the flue gases. This leads to the following:

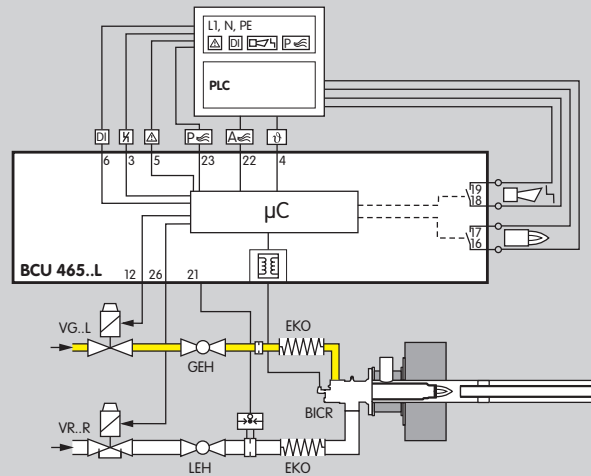
- A reduction in NO_x emissions,
- A uniform radiant tube temperature.

The hot flue gases are fed through the ceramic heat exchanger, heating the additional cold combustion air supply. The maximum achievable air preheat temperature is approx. 400°C.

An internal flame tube must be fitted in the single-ended radiant tube to guide the hot flue gases.

If metal single-ended radiant tubes are fitted horizontally then provision must be made for rotating the tube 180 degrees periodically to extend its working life.

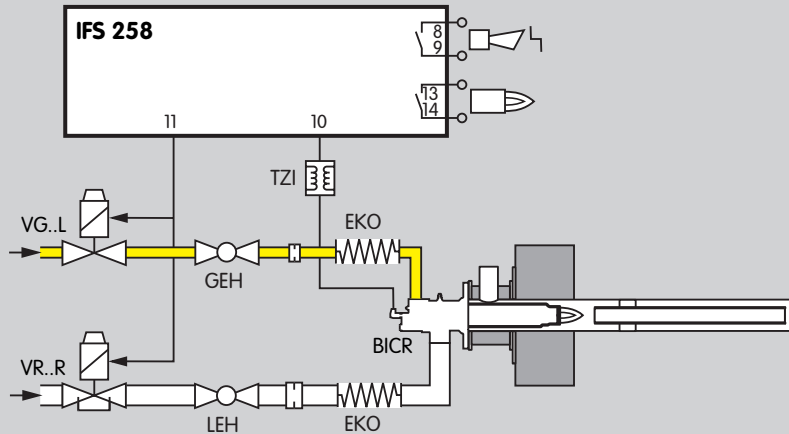
As the BICR burner is slim and compact, it can also be used in radiant tubes that were formerly electrically heated.



1.3.3 BICR in a single-ended radiant tube with burner control unit

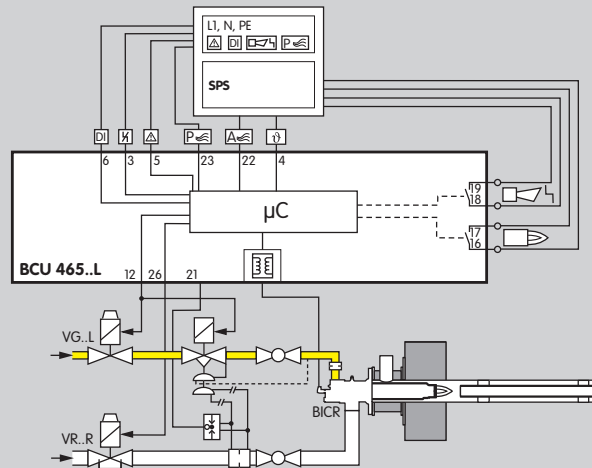
Control example application:
ON/OFF with burner control unit BCU 465..L.

The gas/air mixture is adjusted to the requirements of the applications using the differing parameters of air supply and air post ventilation. The pressure switch monitors the air flow in the air supply line or in the flue gas exhaust.



1.3.4 BICR in a single-ended radiant tube with automatic burner control units

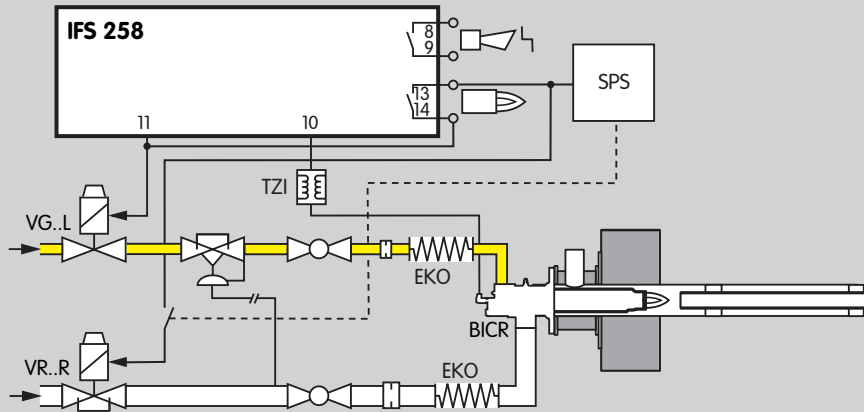
Control example application:
 ON/OFF with automatic burner control units IFS 258 and ignition transformer TZI, external air fan control and central pre-purge.
 Gas valve and air valve are activated simultaneously. The burner is ignited and monitored by a single electrode. There is an immediate fault lock-out following flame failure.



1.3.5 Single-stage-controlled BICR in a single-ended radiant tube with pneumatic link to the burner control unit

Control example application:
ON/OFF with burner control unit BCU 465..L.

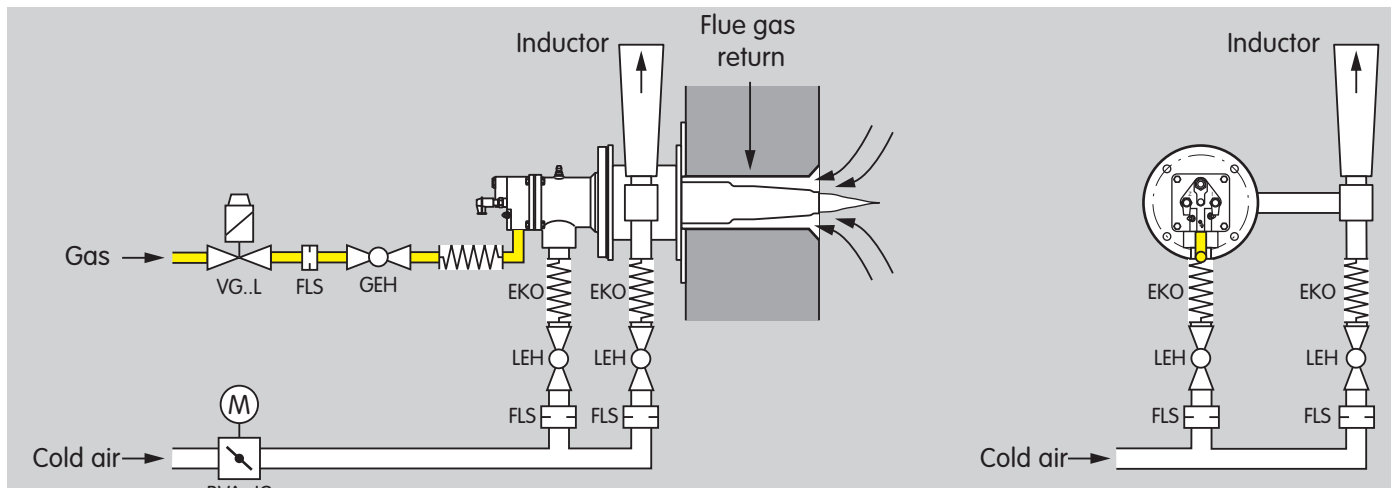
The BCU provides the cooling and purging processes. The variable air/gas ratio control compensates for gas/air pressure fluctuations. The pressure switch monitors the air volume during pre-purge and operation. The gas/air mixture is adjusted to the requirements of the applications using the differing parameters of air supply and air post ventilation.



1.3.6 Single-stage-controlled BICR in a single-ended radiant tube with pneumatic link to the automatic burner control unit

Control example application:
START/HIGH/OFF with automatic burner control units IFS 258.

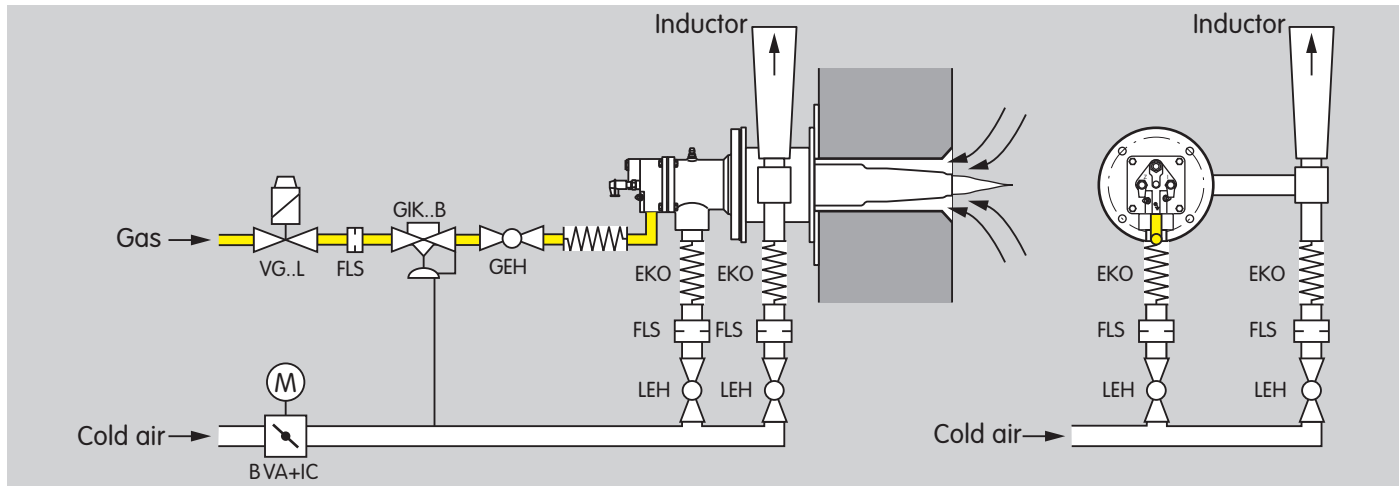
The burner starts at low-fire rate, and a PLC opens the air valve after the operating state has been signalled and thereby switches the burner to high-fire rate. In the event of a flame failure, there is an immediate fault lock-out or a restart.



1.3.7 BICR for direct heating systems

BICR recuperative burner in a direct heating system with optional inductor at the outlet from the exhaust-gas housing (EGH) to evacuate the flue gases from the furnace. The inductor generates a vacuum with a centrally positioned nozzle and thus draws the flue gases out of the furnace chamber through the burner's heat exchanger. The maximum achievable air preheat temperature is approx. 400°C.

- Low air connection pressure at the inductor is required.
- 100% flue gas return through the burner is possible.



1.3.8 BICR for direct heating systems with air deficiency cut-out

BICR recuperative burner in a direct heating system with optional inductor at the outlet from the exhaust-gas housing (EGH) to evacuate the flue gases from the furnace. The inductor generates a vacuum with a centrally positioned nozzle and thus draws the flue gases out of the furnace chamber through the burner's heat exchanger. The maximum achievable air preheat temperature is approx. 400°C.

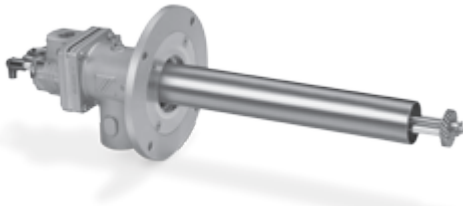
- Low air connection pressure at the inductor is required.
- 100% flue gas return through the burner is possible.

The air/gas ratio control GIK regulates the gas supply dependent on the cold air supply.

2 Mechanical construction

The BICR burner unit is composed of three modules: burner, combustion chamber with heat exchanger and exhaust-gas housing. This structure enables easy adjustment to the respective process or integration into existing systems. Maintenance and repair times are reduced and existing furnace installations can be easily converted.

2.1 Burners BICR



The burner BICR comprises the gas connection flange, the burner air housing and the complete nozzle-mixing burner unit with its ignition and ionisation electrodes. The air guide tube stabilises the cold air flow to the burner head. Gas and air pressures can be easily measured using the gas and air measuring nipples. As of construction stage E, a measuring orifice and flow adjustment are integrated in the gas circuit. Different overall lengths enable precise adjustment to the system requirements.

2.2 Combustion chamber / Heat exchanger TSC



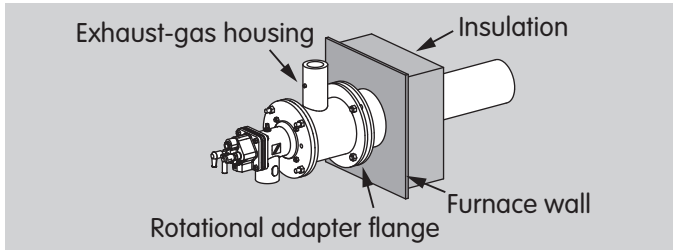
A SiC ceramic tube in light-weight design serves as combustion chamber and, in its cylindrical part, as heat exchanger. The complete combustion of the flame takes place in the front part of the SiC tube.

2.3 Exhaust-gas housing EGH



Interior insulating fittings protect the steel housing from thermal stress. The EGH comprises the furnace flange which is used for attaching the burner unit to the furnace. Flue gases are routed to the outside via internally insulated flue-gas nozzles. Length adjustments are possible.

2.4 Rotational adapter flange



Protects horizontally fitted single-ended radiant tubes against deformation.

This flange is installed between the exhaust-gas housing and the furnace.

3 Function

The burner control unit opens the gas and air solenoid valves. Gas flows through the gas connection flange and air flows through the air housing into the combustion chamber as far as the nozzle-mixing burner head. The burner is directly ignited.

3.1 Indirect heating

The high outlet velocity of the combustion gases generates a pressure at the outlet from the ceramic burner tube resulting in the recirculation of the flue gases. NO_x emissions are reduced. The radiant tube emits an even temperature. The hot flue gases are fed through the ceramic heat exchanger to the exhaust-gas housing, heating the additional cold combustion air supply to max. 400°C. The combustion gases are discharged via the exhaust-gas housing.

3.2 Direct heating

The hot combustion gases flow straight into the furnace. An additional inductor generates a vacuum and thus draws the flue gases out of the furnace chamber through the burner's heat exchanger. During this process, the additional cold combustion air supplied is heated to max. 400°C.

4 Selection

4.1 Burners BICR

	/50 /65 /80	H	B	G	-0	/335 /385 /435 /485 /535 /585 /635 /685 /735 /785	-(1)-(99)	A-Z
BICR 65	●	●	●	●	●	●	●	●
BICR 80	○	●	●	●	●	●	●	●
BICR 100	○	●	●	●	●	●	●	●
Type = BICR + housing size								
Burner size = /50, /65, /80								
Flame shape Long flame = H								
Type of gas Natural gas = B LPG = G								
Length of burner extension 0 mm = -0								
Position of burner head (L2) [mm] = /335, /385, /435, /485...								
Burner head identifier = -(1A), -(2A), -(3A), -(4A), -(5A)...								
Construction stage = A, B, C, D, E...								

● = standard, ○ = available

Order example: **BICR 80/65HB-0/435-(34A)E**

4.2 Exhaust-gas housing EGH

	/50	/65	/80	-190*	-240	-290	-340	-390	
EGH 65	●			●	●	●	●	●	●
EGH 80		●		●	●	●	●	●	●
EGH 100			●	●	●	●	●	●	●
Type = EGH + housing size									
Burner size = /50, /65, /80									
Length of exhaust-gas housing (L8) [mm] = -190*, -240, -290, -340, -390									
To be combined with									
BICR 65/50									
BICR 80/65									
BICR 100/80									

* Standard length: 190 mm

● = standard, ○ = available

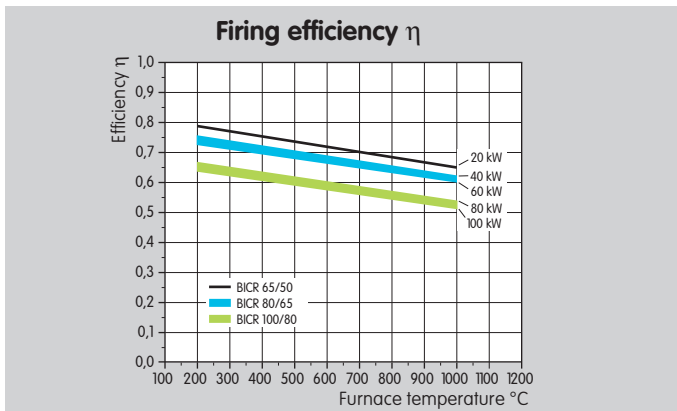
Order example: **EGH 80/65-190**

4.3 Ceramic tube set TSC

	/50 /65 /80	B	022 030 040	-500--900 -550--950	/385--/785 /335--/735	-Si	-1350	
TSC 65	●	●	●	●	●	●	●	●
TSC 80	●	●	●	●	●	●	●	●
TSC 100		●				●	●	●
Type = TSC + housing size								
Burner size = /50, /65, /80								
Tapered shape = B								
Outlet diameter [mm] = 022, 030, 040								
Tube length (L7) [mm]								
-500, -600, -700, -800, -900								
-550, -650, -750, -850, -950								
Position of burner head (L2) [mm]								
/385, /485, /585, /685, /785								
/335, /435, /535, /635, /735								
Ceramic tube made of silicon-infiltrated SiC = -Si								
Up to 1350 °C = -1350								
To be combined with								
BICR 65/50								
BICR 80/65								
BICR 100/80								

● = standard, ○ = available

Order example: **TSC 80/65B030-500/335-Si-1350**



4.4 Burner design

Indirect heating

To calculate the required burner output on the basis of the desired radiation output in the furnace and the furnace temperature:

Determine the firing efficiency for the desired furnace temperature using the diagram.

Required burner output:

$$\frac{\text{Radiation output [kW]}}{\text{Efficiency } \eta} = \text{Required burner output [kW]}$$

Example:

Desired radiation output in the furnace: 27 kW.

Desired furnace temperature: 800°C.

To determine the efficiency: Follow the co-ordinate 800°C on the furnace temperature axis vertically to the point where it intersects with the Efficiency curve η on the required burner output. Then follow the horizontal co-ordinate to the point where it intersects with the efficiency axis. This will give you the Efficiency (≈ 0.67).

$$\frac{27 \text{ [kW]}}{0.67} = 40.2 \text{ [kW]}$$

40.2 kW corresponds to the lower output range of the BICR 80/65.

Direct heating

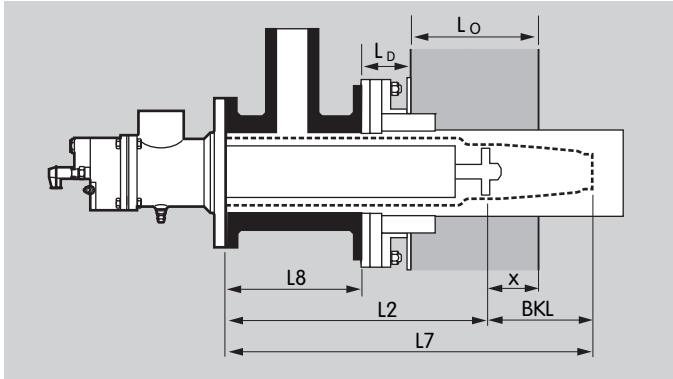
The furnace input corresponds to the burner output.

4.5 Calculating the burner length

Each burner type requires a given combustion chamber length (distance from burner head to TSC tube end) to ensure optimum combustion.

Burner	Burner chamber length (BKL)
	mm
BICR 65/50	115
BICR 80/65	165
BICR 100/80	215

The position of the burner head and the length of the TSC tube depend on the thickness of the furnace wall and the length of the exhaust-gas housing EGH. Should a rotational adapter flange or a flange for attaching the EGH to the furnace be installed, a longer burner and TSC tube should be used.



Legend

- L7 = TSC tube length
- L2 = Position of burner head
- L8 = Length of exhaust-gas housing EGH
- LD = Length of rotational adapter flange or adapter flange
- L0 = Furnace wall thickness
- BKL = Length of combustion chamber
- x = distance between burner head and interior furnace wall

Indirect heating

Position of burner head:

$$L2 = L8 + LD + L0 - (x)$$

BICR 65/50: $x = \frac{BKL}{2} \pm 25 \text{ mm}$

BICR 80/65 and BICR 100/80: $x = \frac{BKL}{2} + 30 \text{ mm}$

to

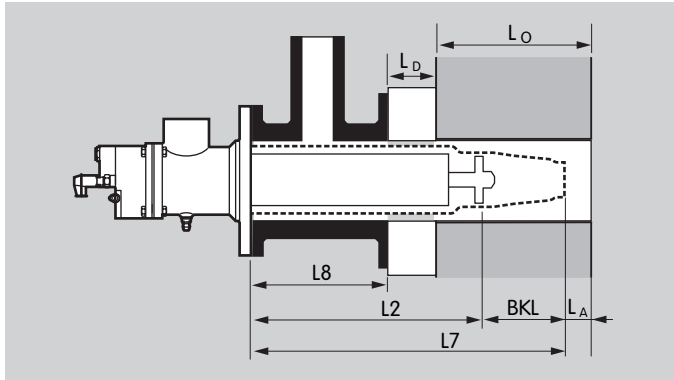
$$x = \frac{BKL}{2} - 20 \text{ mm}$$

LD = 0, unless rotational adapter flange or adapter flange are installed.

Suitable TSC tube length:

$$L7 = L2 + BKL$$

We recommend to adapt the position of the burner head, TSC tube length and EGH length so that the opening of the TSC tube projects into the interior of the furnace by half the combustion chamber length (tolerance on BICR 65/50: $\pm 25 \text{ mm}$, BICR 80/65 and BICR 100/80: $- 20 \text{ mm} / + 30 \text{ mm}$).



Legend

- L7 = TSC tube length
- L2 = Position of burner head
- L8 = Length of exhaust-gas housing EGH
- LD = Length of rotational adapter flange or adapter flange
- LO = Furnace wall thickness
- BKL = Length of combustion chamber
- LA = Distance between TSC tube end and interior furnace wall (≤ 50 mm)

Direct heating

Position of burner head:

$$L2 = L8 + LD + LO - BKL - LA$$

$LD = 0$, unless adapter flange is installed.

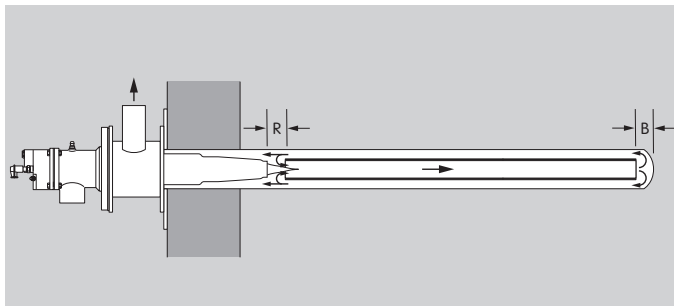
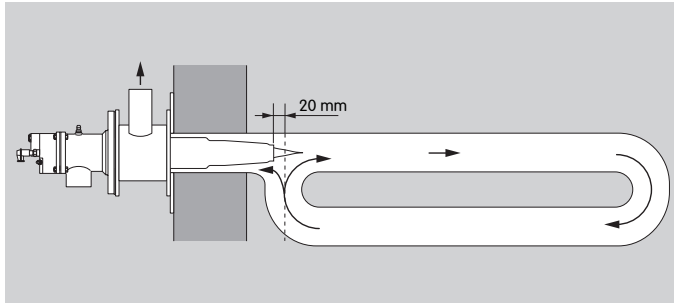
$$LA \leq 50 \text{ mm.}$$

Suitable TSC tube length:

$$L7 = L2 + BKL$$

We recommend to adapt the EGH length, position of the burner head and TSC tube length so that the opening of the TSC tube does not project into the interior of the furnace.

The end of the TSC tube may be positioned in the flue gas return at a distance of less than 50 mm from the interior furnace wall.



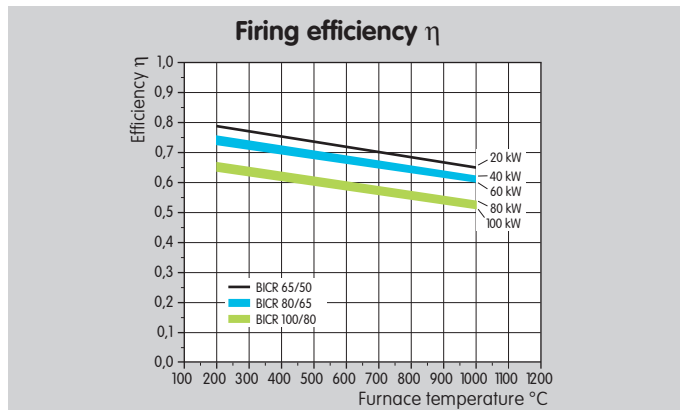
5 Project planning information

5.1 Indirect heating

A single-ended radiant tube, P radiant tube or twin P radiant tube is required. Diameter and length of the radiant tube must be suited to the burner:

BICR	Single-ended, P, twin P radiant tube				
	Internal dia. \varnothing [mm]			Heated length [mm]	
	min.	optimal	max.	min	max.
65/50	79	109	145	90	On request
80/65	108	138	200	1500	On request
100/80	143	173	300	1800	On request

BICR	Single-ended radiant tube	
	Recirculation gap R [mm]	Deflector gap B [mm]
65/50	60 (± 10)	Radiant tube internal dia.
80/65	90 (± 10)	Radiant tube internal dia.
100/80	140 (± 10)	Radiant tube internal dia.



Calculating the radiation output of the radiant tube:

$$\frac{P \times \eta}{A} = WB$$

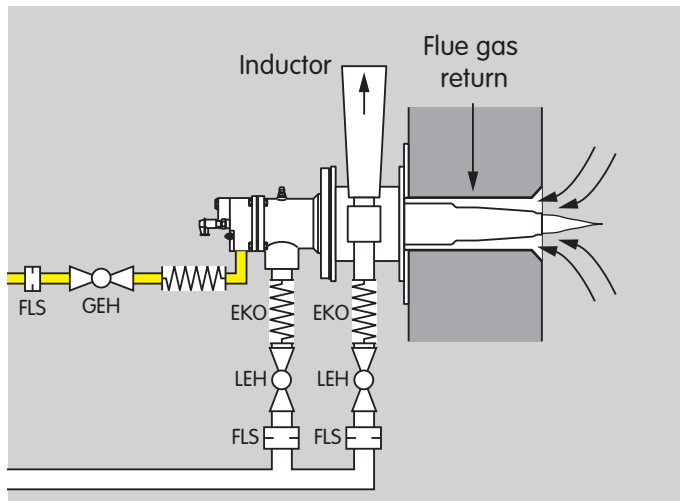
P (burner output) [W]
 WB (radiant tube radiation output*) [W/cm²]
 WB (radiant tube radiation output) [W/cm²]
 A [cm²] = D_a [cm] \times L [cm] \times π
 D_a (radiant tube external diameter) [cm]
 L (radiant tube length)* [cm]
 η (firing efficiency)

* Heated radiant tube length

Example:

$$T_{\text{Furnace}} = 700^{\circ}\text{C} \quad \frac{20000 \text{ W} \times 0,7}{5702 \text{ cm}^2} = 2,46 \text{ W/cm}^2$$

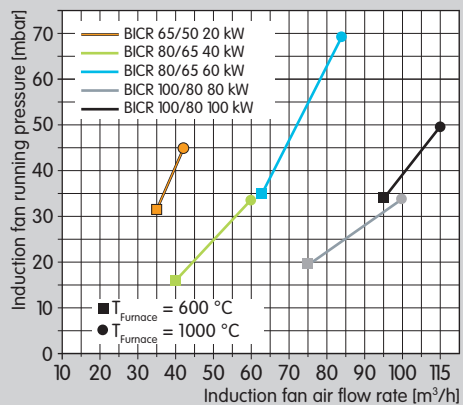
Burner BICR 65/50:
 $P = 20000 \text{ W}$
 Radiant tube:
 $D_a = 12,1 \text{ cm}$
 $L = 150 \text{ cm}$
 $\pi = 3,1416$
 $A = D_a \times L \times \pi = 5702 \text{ cm}^2$
 η (at a furnace temperature of 700°C) = 0,7
 $WB = 2,46 \text{ W/cm}^2$

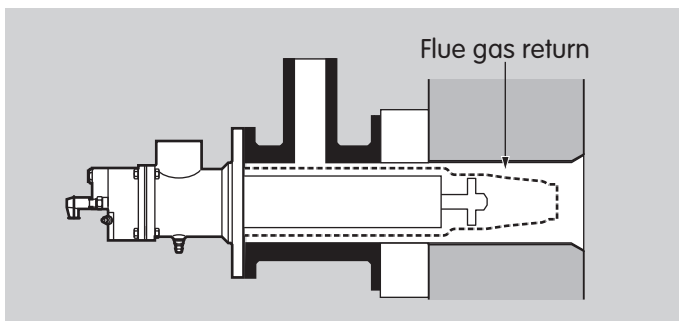
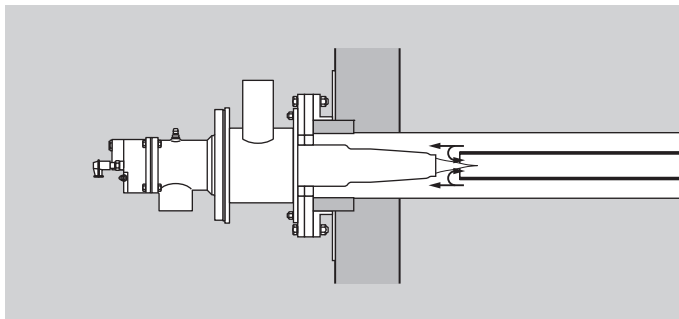


5.2 Direct heating

An additional inductor to return the flue gases has to be fitted. The air flow supplied to the inductor is approx. 1.5 times the required burner air flow (which ensures 100% flue gas return through the burner with no other flue gas channelling required).

Running pressure and air flow rate for induction fan





5.3 Installation

Installation position: Arbitrary.

Gas and air connection: Can be rotated in 90° steps

Indirect heating

When designing a burner to be combined with a radiant tube, attention must be paid to the tube capacity and heat transfer rate of the material used.

If a BICR recuperative burner is installed in a horizontal metal radiant tube, then provision must be made for rotating the tube.

The time intervals for the turning of the metallic radiant tubes depend on the furnace temperature and the thermal stress of the radiant tube. Note the recommendations made by the radiant tube manufacturer.

Direct heating

Fit a flue gas return in the furnace wall for the flue gases. The flue gas return shall have the same internal diameter as the exhaust-gas housing EGH.

BICR	Flue gas return Internal diameter [mm]
65/50	79
80/65	108
100/80	143

5.4 Recommended ignition transformer

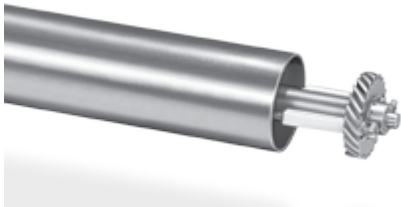


≥ 7.5 kV, ≥ 12 mA, e.g. TZI 7,5-12/100 or TGI 7,5-12/100.

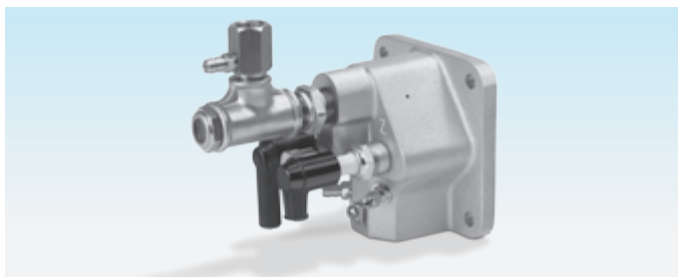
5.5 Nozzle-mixing burners

Non-return gas valves are not required, since the burners are of the nozzle-mixing type.

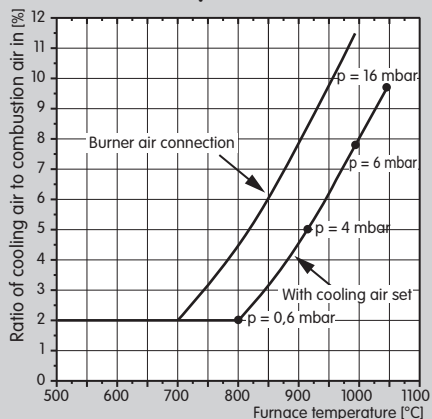
5.6 Flame control



The flame is monitored by an ionisation electrode.



**Minimum BICR cooling air
at a furnace pressure < 0.2 mbar**



5.7 Cooling the recuperative burner

The optionally available cooling air set improves cooling of the burner BICR. When the burner is switched off, the air volume required for cooling the burner components can be minimised. The cooling air can be supplied via a separate cooling air connection. To avoid condensation due to the furnace atmosphere entering the burner housing, and for cooling purposes, a low air volume (approx. 1–4% of the high-fire volume) must flow while the burner is switched off. The air fan should not be switched off until the furnace has cooled down completely.

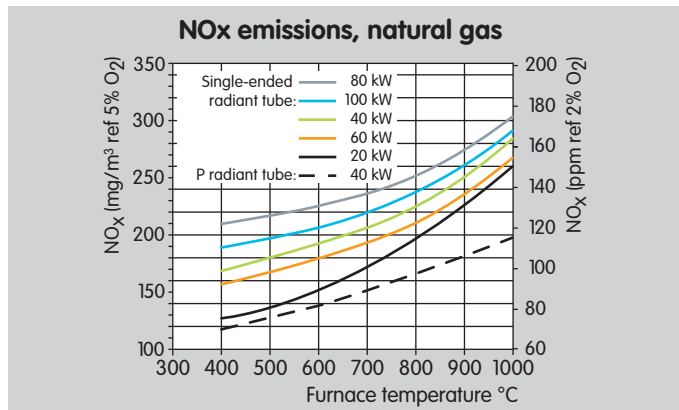
Install, insulate and operate the burner in order to avoid any overheating of the components.

When the cooling air set and burner are ordered simultaneously, the parts will be assembled at the factory.

Subsequent retrofitting of burners on site is possible.

Burner	Combustion air [m ³ /h]
BICR 65/50	20
BICR 80/65	40 – 60
BICR 100/80	80 – 100

For indirect heating (pressure in radiant tube > 0.2 mbar) the reverse flow pressure is to be added to the cooling air pressure p .



5.8 Emissions

Emissions do not exceed the limits stipulated by the German Technical Instructions on Air Quality Control.

NO_x values depend on the temperature, combustion chamber, furnace chamber, λ value and output.

If operated with LPG, NO_x values are approx. 25% higher.

5.9 Gas line connection

To ensure accurate measurements of the pressure differential on the integrated gas measuring orifice for burners BICR 80/65 and BICR 100/80 as from construction stage E, the following applies for the design of the gas connection:

- Ensure undisturbed flow to the gas connection on the burner for a distance of ≥ 5 DN.
- Use a flexible tube unit with the same nominal dimensions as the gas connection on the burner.
- Use a pipe bend up to an angle of 90° with the same nominal dimensions as the gas connection on the burner.
- Only use reducing nipples with an external thread at both ends in order to reduce the nominal diameter on the burner (e.g. from 1" to ¾").

To ensure optimum flow, to avoid incorrect measurements and to enable burner operation with excess gas, we recommend the following:

- Do not screw the manual valve directly into the burner.

5.9.1 System with or without pneumatic air/gas ratio control system

To set the burner, we recommend measuring the flow rate using the measuring orifice FLS on the gas and air sides. On the BICR 80/65 and BICR 100/80, there is already a gas measuring orifice installed in the burner housing.

5.9.2 Systems without a pneumatic link

Operate the system at a higher supply pressure in the gas and air supply lines.

Pressure loss occurs at the measuring orifices. To improve the ignition capability, the start gas rate of the slow-opening gas solenoid valve can be increased.

A minimum combustion time of 20 s should be observed.

Further control options are available on request.

Example of a gas connection

Burner	Valve	Measuring orifice
BICR 65/50HB	VAS 115..L	FLS 110 Bohr-Ø 6 mm
BICR 65/50HG	VAS 115..L	FLS 110 Drilling dia. 4 mm
BICR 80/65HB	VAS 115..L	Not required
BICR 80/65HG	VAS 115..L	Not required
BICR 100/80HB	VAS 115..L	Not required
BICR 100/80HG	VAS 115..L	Not required

Example of an air connection

Brenner	Output kW	Valve		Measuring orifice (drilling dia.)
		Indirect heating	Direct heating	
BICR 65/50	20	VR 25..R	VR 40..R	FLS 125 (18 mm)
BICR 80/65	40	VR 40/32..R	VR 50..R	FLS 240 (24 mm)
BICR 80/65	60	VR 40/32..R	VR 50..R	FLS 240 (28 mm)
BICR 100/80	80	VR 50..R	BVHM 50..R, VR 65..R	FLS 350 (34 mm)
BICR 100/80	100	VR 50..R	BVHM 50..R, VR 65..R	FLS 350 (38 mm)

6 Technical data

Burner length increments: 100 mm.

Types of gas: Natural gas or LPG (gaseous); other gases on request.

Heating: Direct with inductor or indirect in radiant tube.

Control type: On/Off.

Flame velocity: High.

Most of the burner components are made of corrosion-resistant stainless steel.

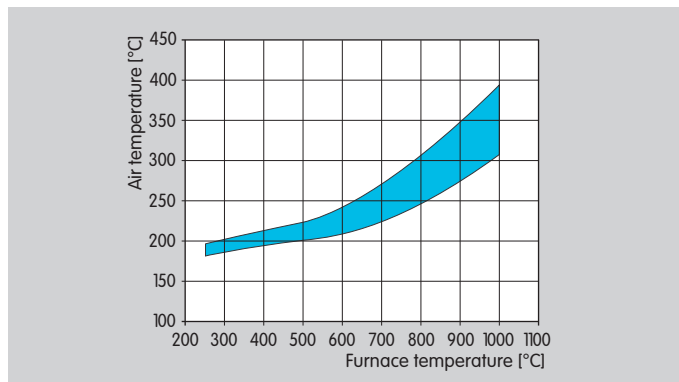
Exhaust-gas housing EGH with internal ceramic fibre insulation (RCF).

Flame control: Direct ionisation control.

Ignition: Direct, electrical.

Maximum furnace temperature: approx. 950°C for indirect heating, approx. 1050°C for direct heating.

Air temperature (indirect heating):



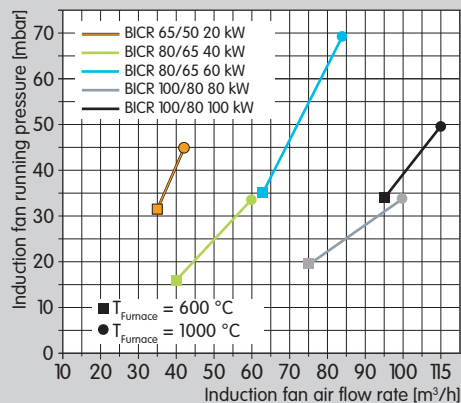
Burner output and required connection pressure at a furnace temperature of 900 °C for indirect heating with natural gas in a radiant tube:

Burner	Output kW	Gas mbar	Air mbar
BICR 65/50	20	27	35
BICR 80/65	40	25	30
BICR 80/65	60	51	55
BICR 100/80	80	26	32
BICR 100/80	100	41	48

The reverse flow pressure via the radiant tube is to be taken into consideration.

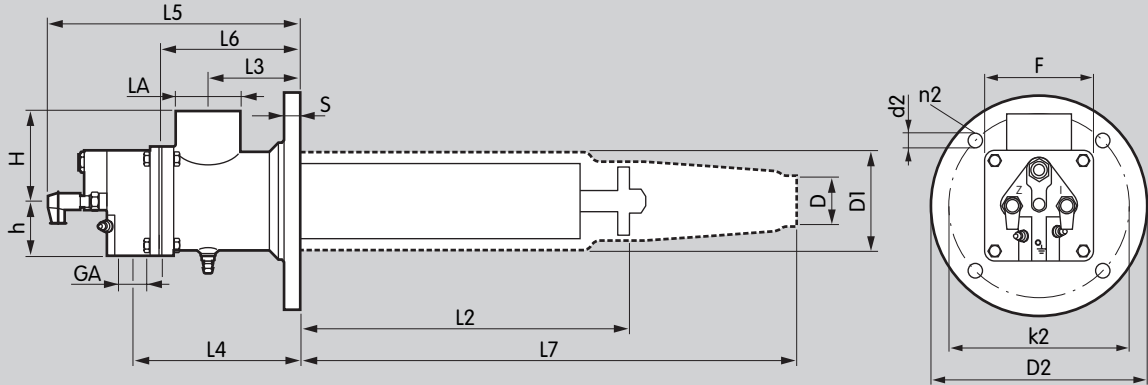
Burner output and required connection pressure for other furnace chamber temperatures, heating modes or LPG: On request.

Running pressure and air flow rate for induction fan



6.1 Dimensions

6.1.1 BICR + TSC

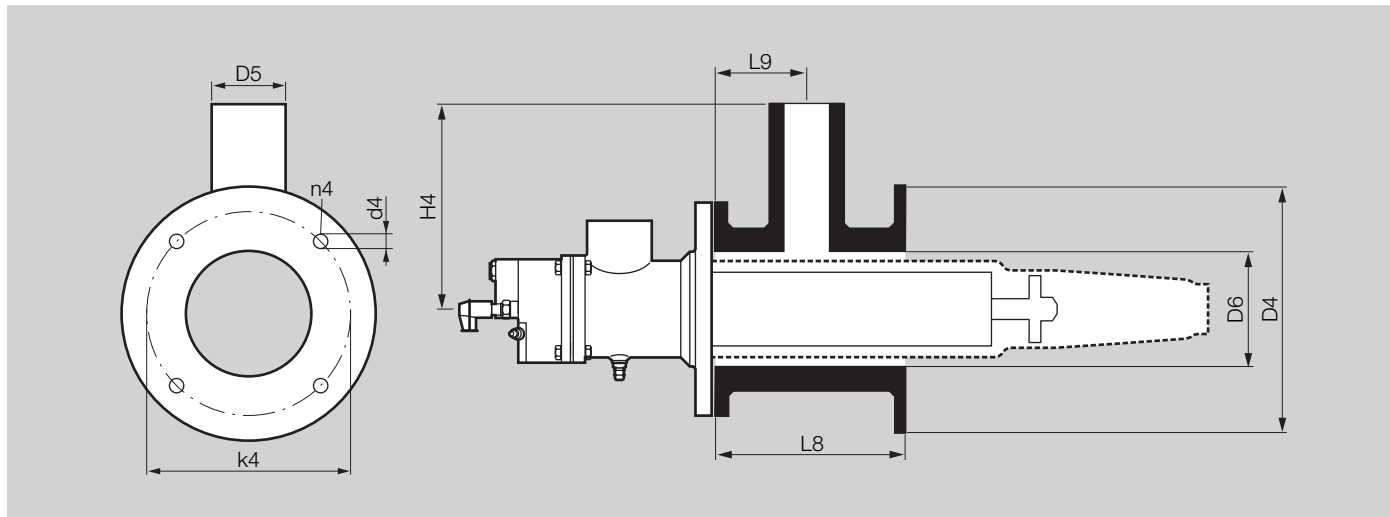


Type	Dimensions																Weight		
	[mm]																		
	D	D1	GA	LA	H	h	S	L2*	L3	L4	L5	L6	L7	D2	k2	d2	n2	F	[kg]**
BICR 65/50	22	68	Rp 1/2	Rp 1 1/2	62	38	12	385-785	73	159	251	127	500-900	195	165	12	4	95	7,95
BICR 80/65	30	87	Rp 3/4	Rp 2	112	55	14	335-735	90	182	282	140	500-900	240	210	14	4	110	13,3
BICR 100/80	40	110	Rp 3/4	Rp 2	100	60	16	335-735	103	195	320	153	550-950	240	200	14	4	120	14,7

* in 100 mm increments

** Shortest overall length

6.1.2 EGH



Type	Dimensions								
	[mm]								
	L8*	L9	H4	D4	D5	D6	k4	d4	n4
BICR 65/50	190	90	204	240	65	79	200	14	4
BICR 80/65	190	90	218	260	102	108	220	14	4
BICR 100/80	190	90	236	300	102	143	260	14	4

* Other lengths on request.

7 Maintenance cycles

Twice per year, but if the media are highly contaminated, this interval should be reduced.

8 Accessories

Cooling air set



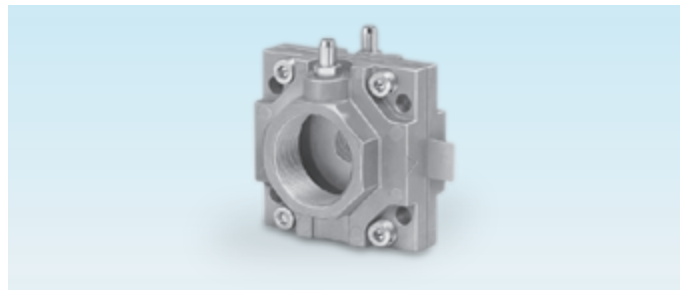
The optionally available cooling air set improves cooling of the burner BICR.

When the cooling air set and burner are ordered simultaneously, the parts will be assembled at the factory.

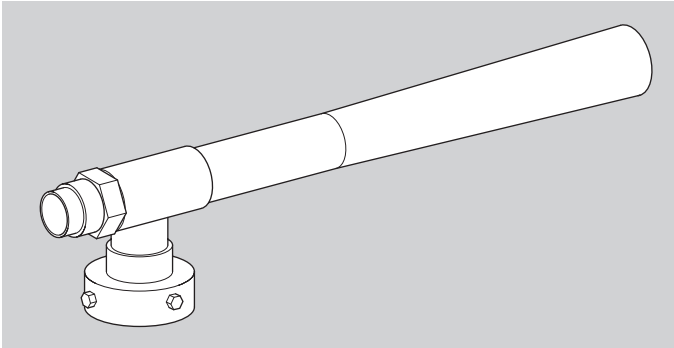
Subsequent retrofitting of burners on site is possible.

Burner	Cooling air connection
BICR 65/50	Rp 1/4
BICR 80/65	Rp 3/8
BICR 100/80	Rp 1/2

Measuring orifice FLS



The appropriate differential pressure can be checked using two pressure test points before and after the orifice.



Induction fan set

For 100% flue gas return through the burner. No other flue gas channelling is required.

Feedback

Finally, we are offering you the opportunity to assess this “Technical Information (TI)” and to give us your opinion, so that we can improve our documents further and suit them to your needs.

Clarity

- Found information quickly
- Searched for a long time
- Didn't find information
- What is missing?
- No answer

Comprehension

- Coherent
- Too complicated
- No answer

Scope

- Too little
- Sufficient
- Too wide
- No answer

Use

- To get to know the product
- To choose a product
- Planning
- To look for information

Navigation

- I can find my way around
- I got “lost”
- No answer

My scope of functions

- Technical department
- Sales
- No answer

Remarks

(Adobe Reader 7 or higher required)
www.adobe.com

Contact

Elster GmbH
 Postfach 2809 · 49018 Osnabrück
 Strothweg 1 · 49504 Lotte (Büren)
 Germany
 T +49 541 1214-0
 F +49 541 1214-370
info@kromschroeder.com
www.kromschroeder.com
www.elster.com

The current addresses of our international agents are available on the Internet:
www.kromschroeder.de/index.php?id=718&L=1

We reserve the right to make technical modifications in the interests of progress.
 Copyright © 2011 Elster Group
 All rights reserved.